

Pulse Meter

- Author: GODINEL Daria-Teodora
- Group: 1221EA
- Faculty: FILS

Introduction

As the name says, the device I am doing is a Pulse Meter, which measures the pulse if the person is placing their finger on a sensor. The difference between a good pulse which will be shown by the colour green, a slightly higher pulse shown by the colour yellow and a possibly dangerous high pulse shown by the colour red. This type of device is used by both common people at home, as well as by the medical personnel in usual or urgent cases in the hospital for emergencies.

General description

The Pulse Meter project works by using a sensor that detects the pulse when one's finger is placed on top of it. As a result, the signal is sent to the Arduino Uno which will show the pulse on the LCD screen. Every time when a heartbeat is detected, a red led will turn on. The result is also displayed by using RGB LEDs:

- when the pulse is between 60 and 100 BPM, the GREEN color will be shown;
- when the pulse is between 100 and 140 BPM, the YELLOW color will be shown;
- when the pulse is between 140 and 160 BPM, the RED color will be shown;

On top of everything, if the pulse reaches 160 BPM, all LEDs will show the color RED.

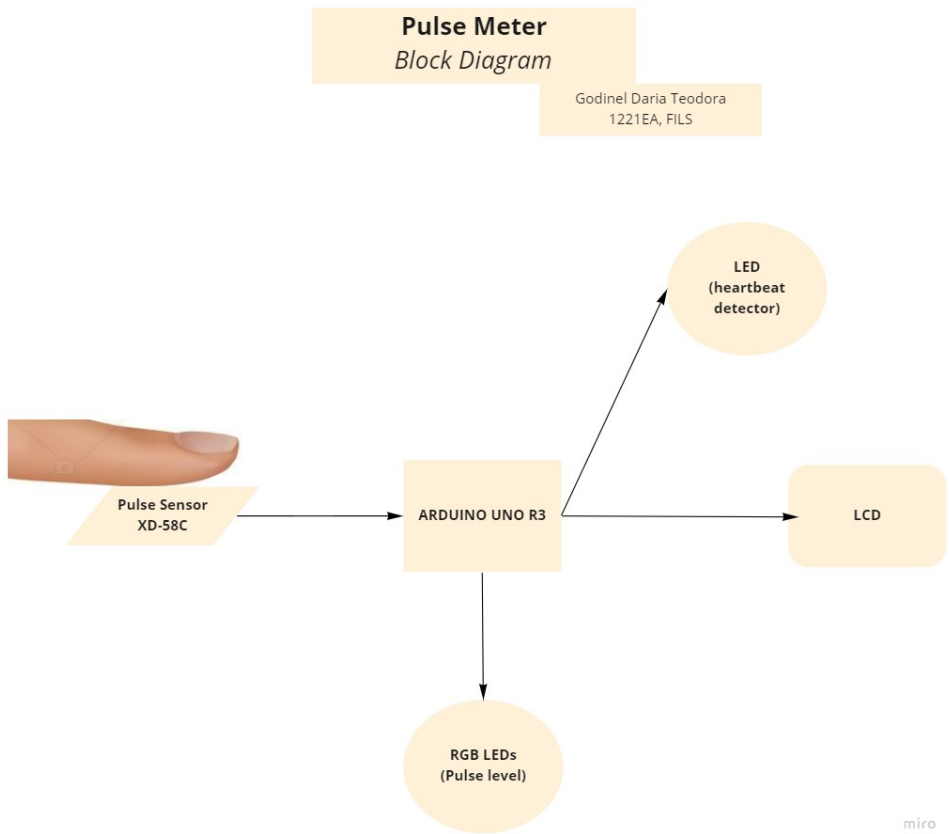

Hardware Design

COMPONENTS

- Arduino Uno R3
- Breadboard
- Pulse Sensor XD-58C
- RED LED
- RGB LEDs
- LCD-I2C
- Jumper wires - male-to-male
- Jumper wires - male-to-female

Electrical schematic

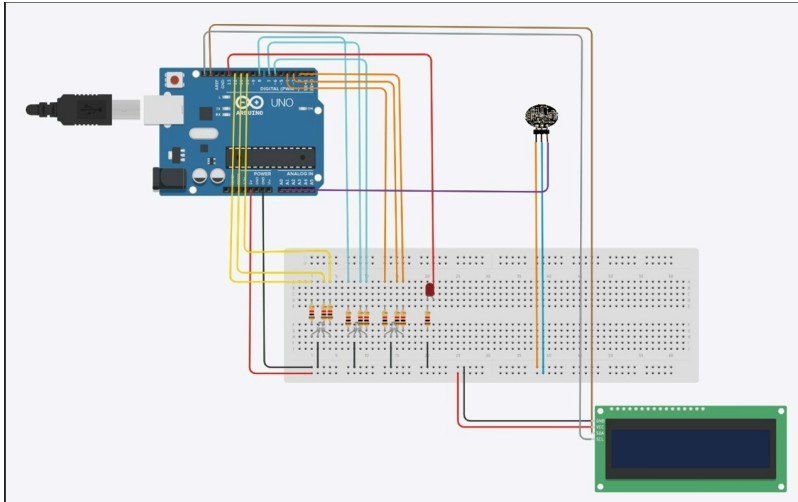

Software Design

I developed this project using Arduino IDE.

Used libraries:

- For the LCD: LiquidCrystal_I2C.h
- For the pulse sensor: PulseSensorPlayground.h

Results Obtained

This project uses a pulse meter that by touching with your finger the sensor, it can determine your pulse and to show the value on the LCD screen. For every heart beat, the LED will light and the RGB LEDs will show the level the person's heartbeat is classified.

The circuit:

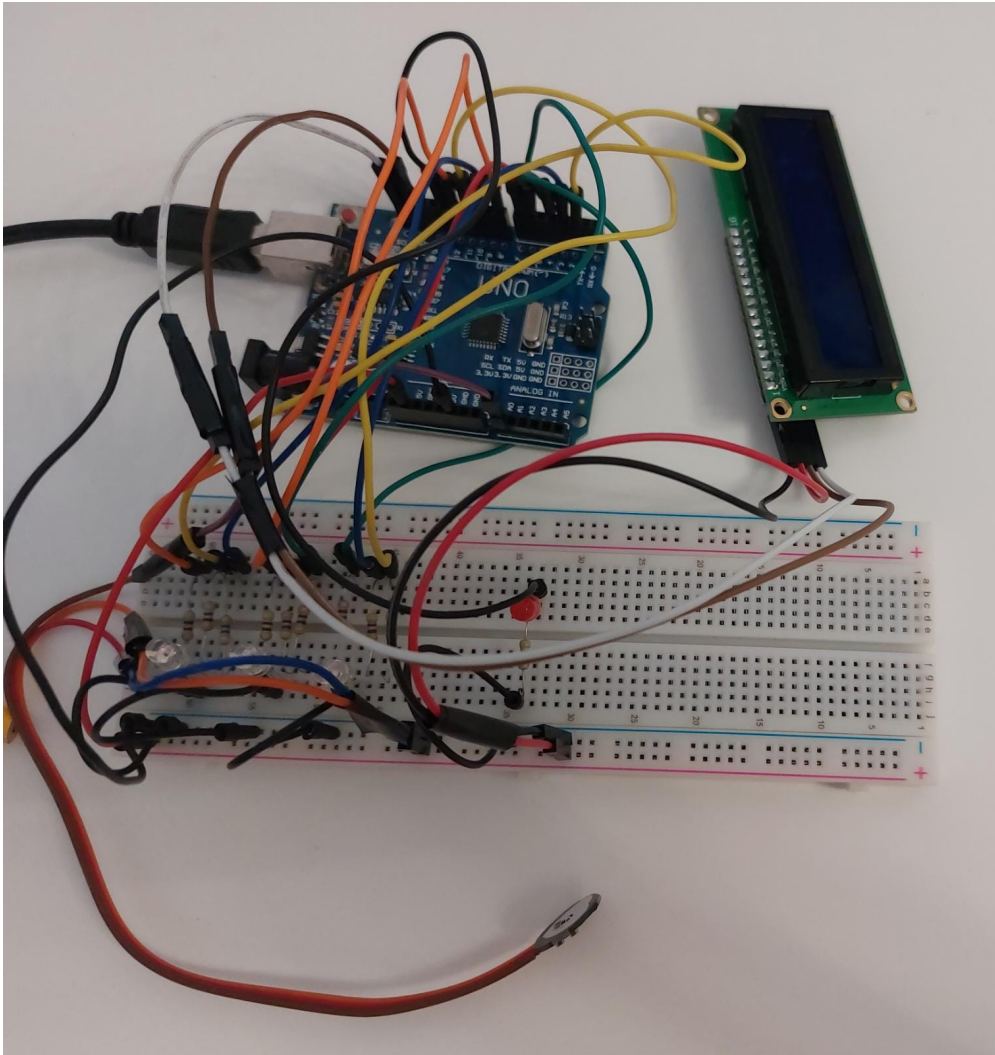

Exemple of the project working:

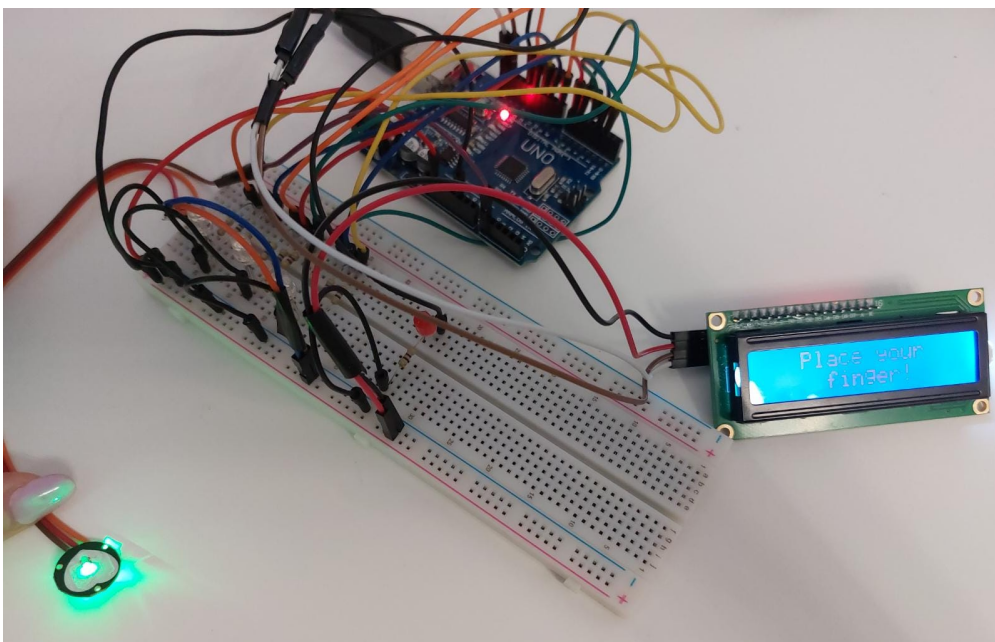

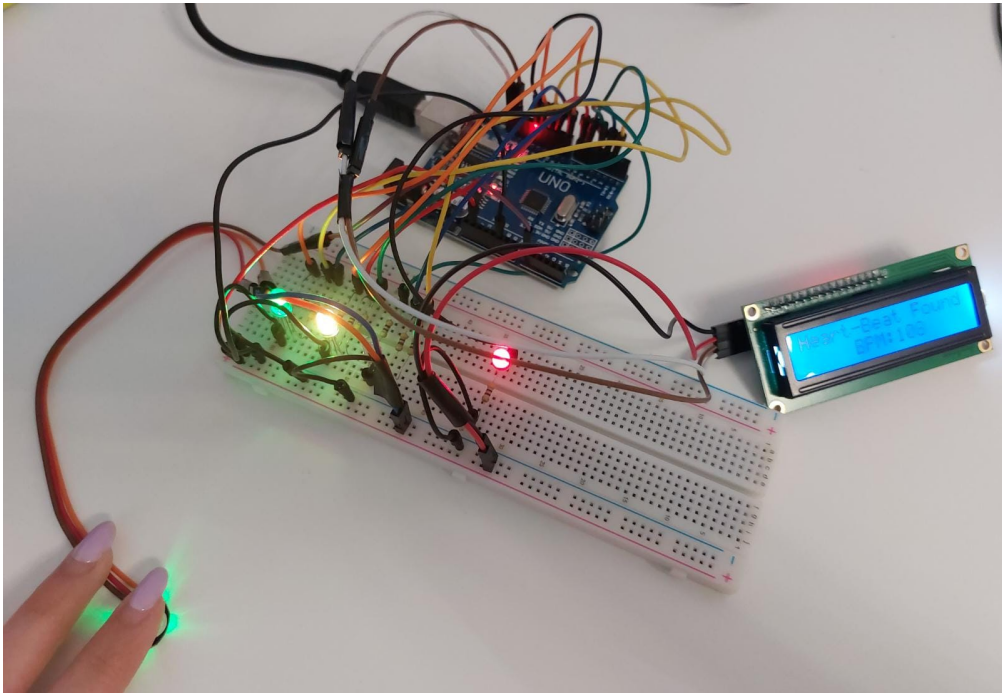
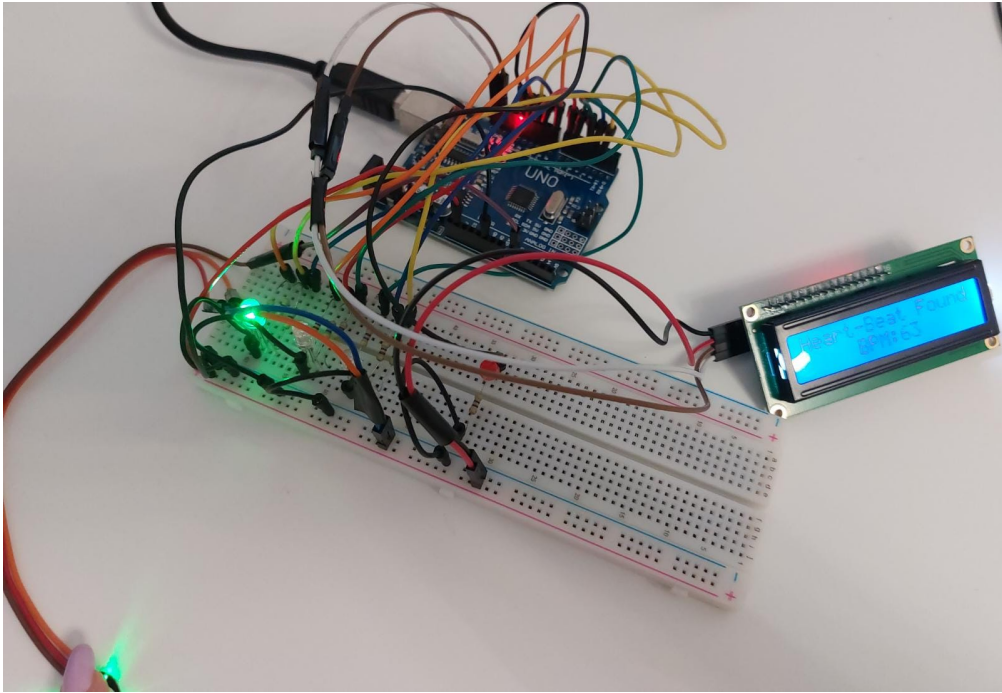

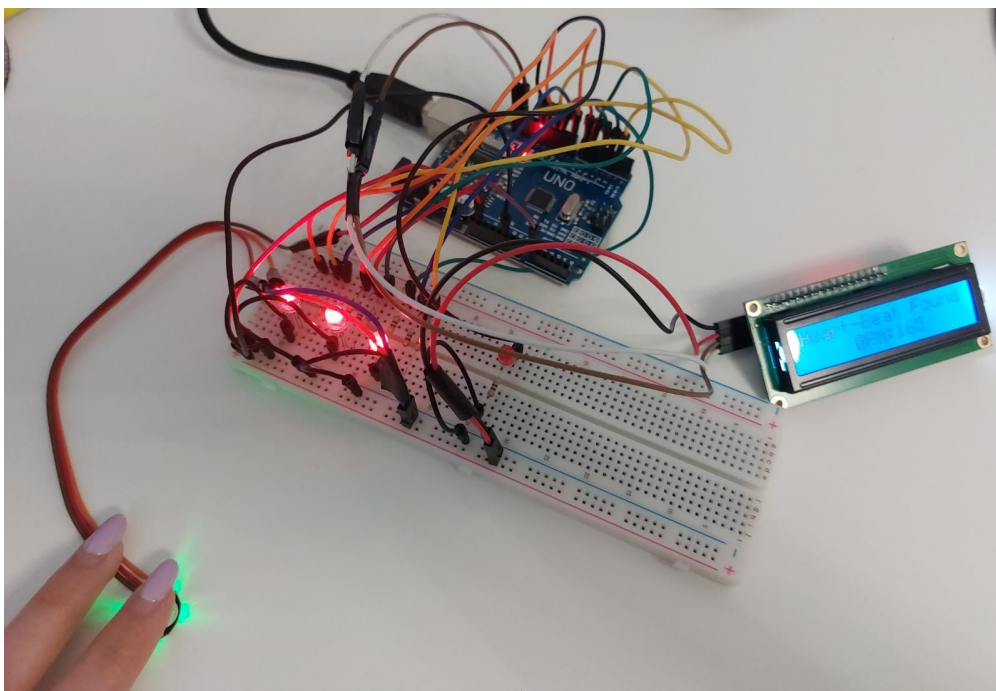
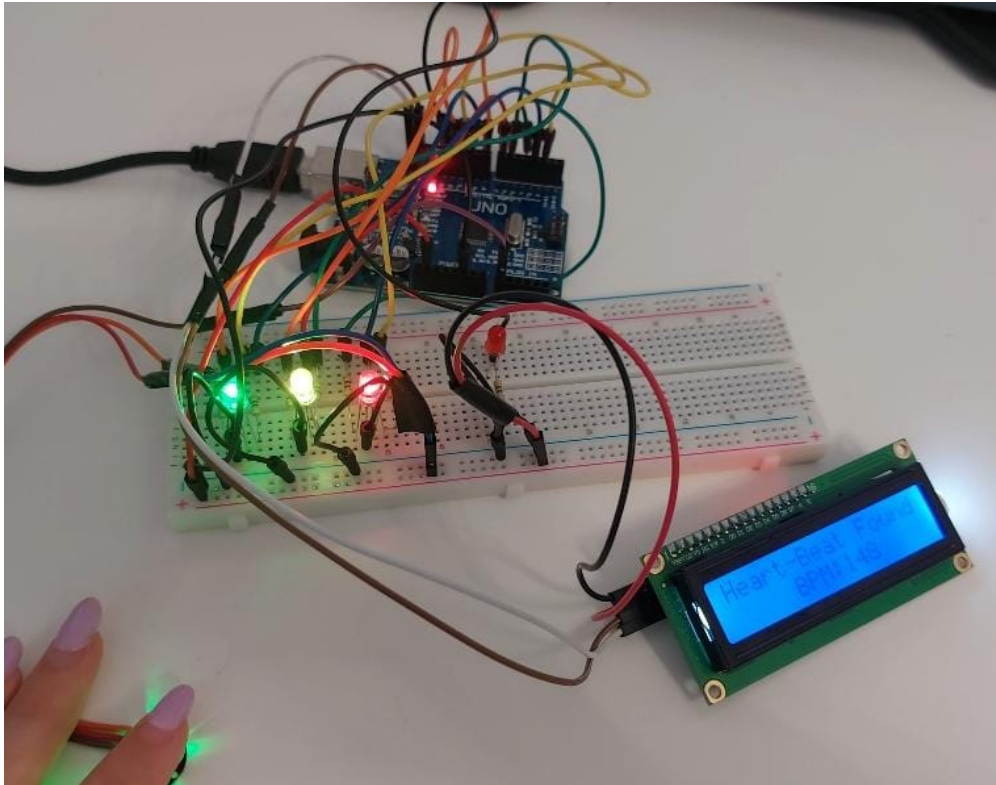

Conclusions

After a long journey of learning, working, making mistakes and trying again, this project has resulted in a perfectly functional pulse meter, that is usable for anyone and any environment.

Download

[pulse_meter.zip](#)

Journal

- Week 1: I started to do reasearch for the project theme and to choose the one that appealed to me the most
- Week 2: I placed the command for the materials
- Week 3: The start of the actual project (the circuit, the code and the wiki page)
- Week 4: I presented the project at the laboratory and finished the wiki page.

Bibliography

<https://ocw.cs.pub.ro/courses/pm/lab/lab1-2022>

<https://ocw.cs.pub.ro/courses/pm/cursuri/curs1>

<https://lastminuteengineers.com/pulse-sensor-arduino-tutorial/>

<https://www.instructables.com/How-to-Connect-I2C-Lcd-Display-to-Arduino-Uno/>

<https://create.arduino.cc/projecthub/shubhamsuresh/diy-pulse-oximeter-bf62c3>

<https://miro.com/templates/block-diagram>

<https://www.tinkercad.com/dashboard>

[Export to PDF](#)

From:

<http://ocw.cs.pub.ro/courses/> - **CS Open CourseWare**

Permanent link:

<http://ocw.cs.pub.ro/courses/pm/prj2022/robert/pulsemeter>



Last update: **2022/05/27 17:18**