

WIRELESS SENSOR NETWORKS

Dan Ștefan Tudose

Facultatea de Automatică și Calculatoare
Universitatea Politehnica București



<http://dilbert.com/strips/comic/2010-04-24/>

Moore

Procesare
Era informației

More than Moore

Detectie
Era interacției

Beyond Moore

Actuare
Era îmbunătățirii

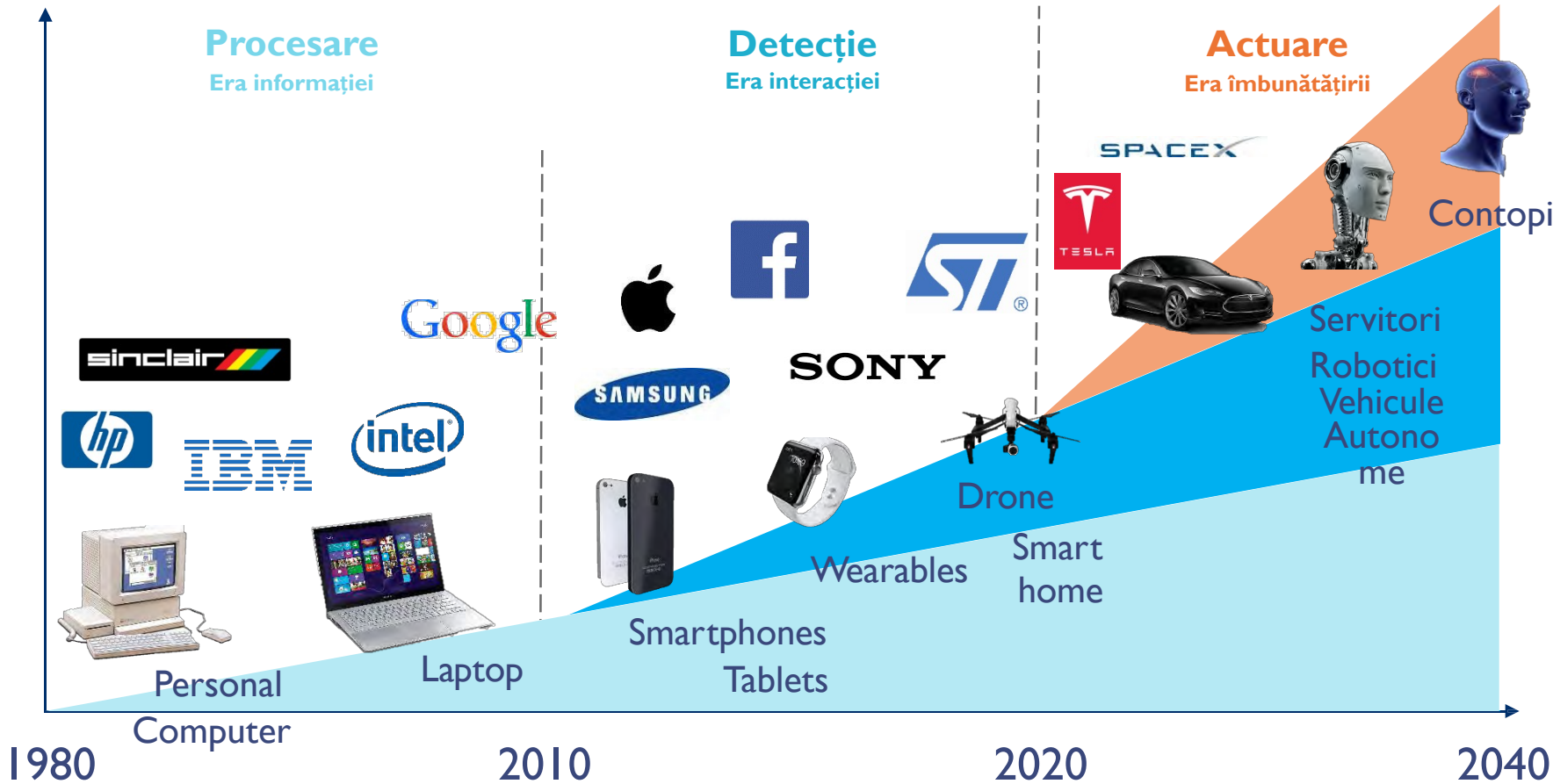

Creștere exponențială

Emerging Technology Hype Cycle

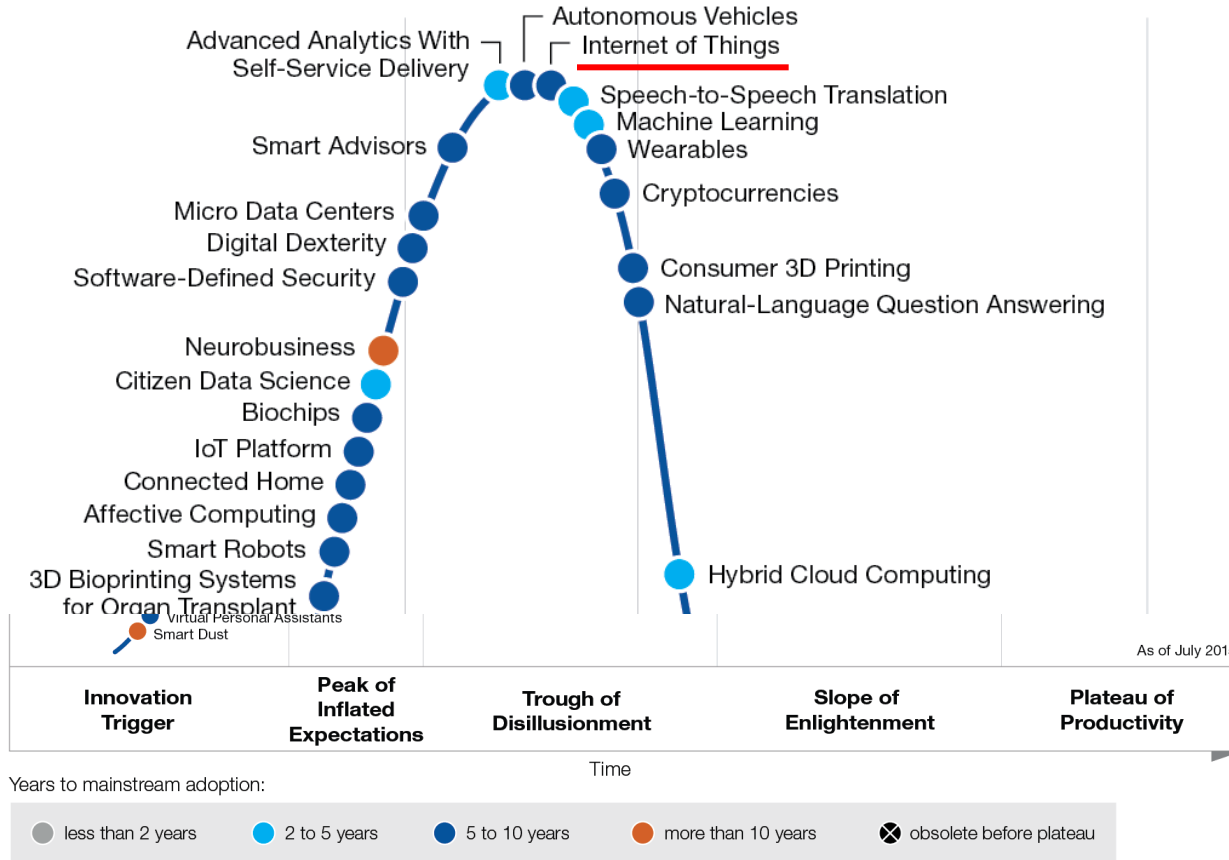

Wireless Sensor Networks

- Sensori multipli (uneori sute sau mii) formează o **rețea** cu scopul de a monitoriza medii fizice complexe sau de mari dimensiuni
- Informația culeasă este transmisă **wireless** către un **base station (BS)**, ce o propagă mai apoi altor dispozitive pentru stocare, analiză și procesare

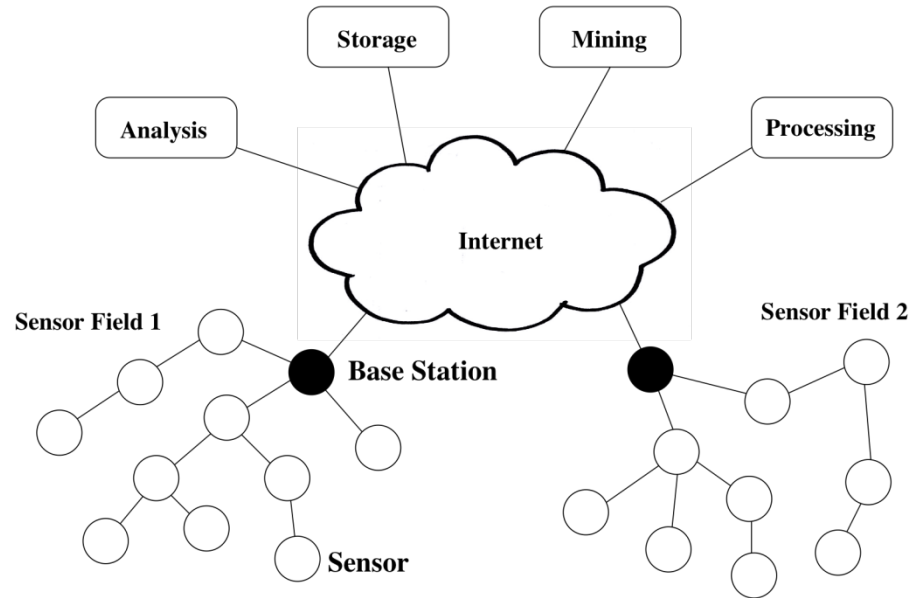

Scurt Istoric

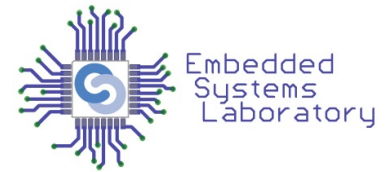

- DARPA:
 - Distributed Sensor Nets Workshop (1978)
 - Distributed Sensor Networks (DSN) program (early 1980s)
 - Sensor Information Technology (SensIT) program
- UCLA and Rockwell Science Center
 - Wireless Integrated Network Sensors (WINS)
 - Low Power Wireless Integrated Microsensor (LWIM) (1996)
- UC-Berkeley
 - Smart Dust project (1999)
 - Conceptul de “**notes**”: noduri senzoriale extrem de mici
- Berkeley Wireless Research Center (BWRC)
 - PicoRadio project (2000)
- MIT
 - μ AMPS (micro-Adaptive Multidomain Power-aware Sensors) (2005)



- Rețele wireless de senzori comerciale
 - Crossbow (www.xbow.com)
 - Sensoria (www.sensoria.com)
 - Worldsens (worldsens.citi.insa-lyon.fr)
 - Dust Networks (www.dustnetworks.com)
 - Ember Corporation (www.ember.com)

Cum am ajuns aici?

- Dezvoltarea tehnologiei wireless
 - ▣ MEMS, VLSI
 - ▣ Bandwidth explosion
- Schimbări culturale și de legislație
 - ▣ Dispozitivele wireless sunt peste tot și oamenii sunt din ce în ce mai receptivi la noi aplicații
 - ▣ Conceptul de rețea (nu numai de date) este unul de bază în societatea noastră
 - ▣ Open source
- Computer Science
 - ▣ Teoria rețelelor, sistemelor de operare
 - ▣ Compilatoare ieftine și universal disponibile

Micro-Electro-Mechanical-Systems (MEMS)

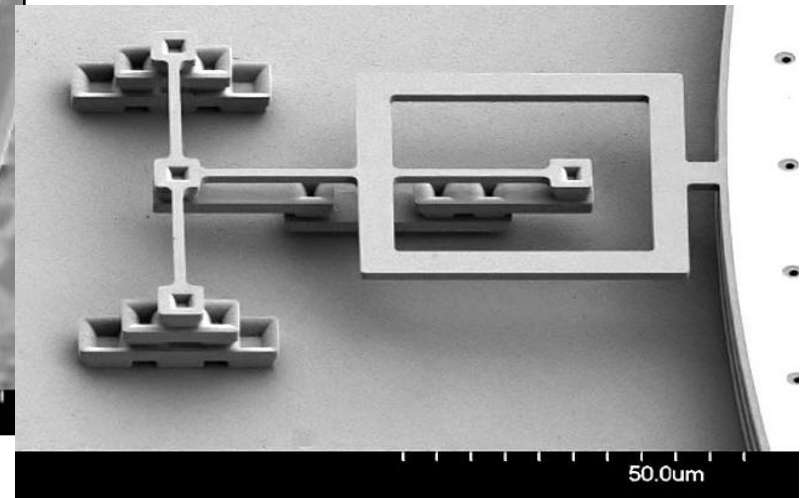
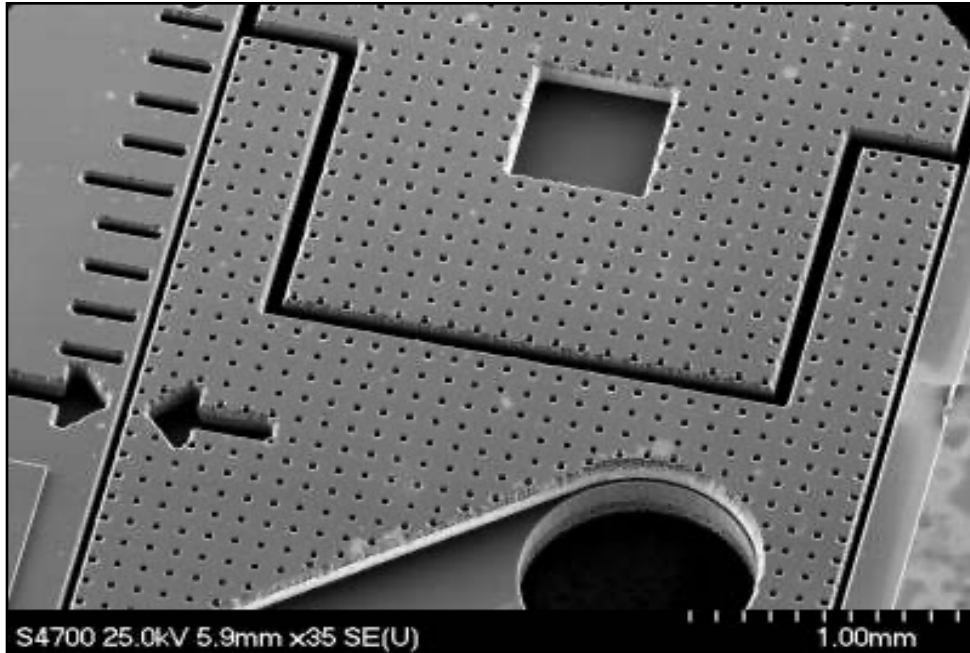

Micro-Electro-Mechanical-Systems (MEMS)

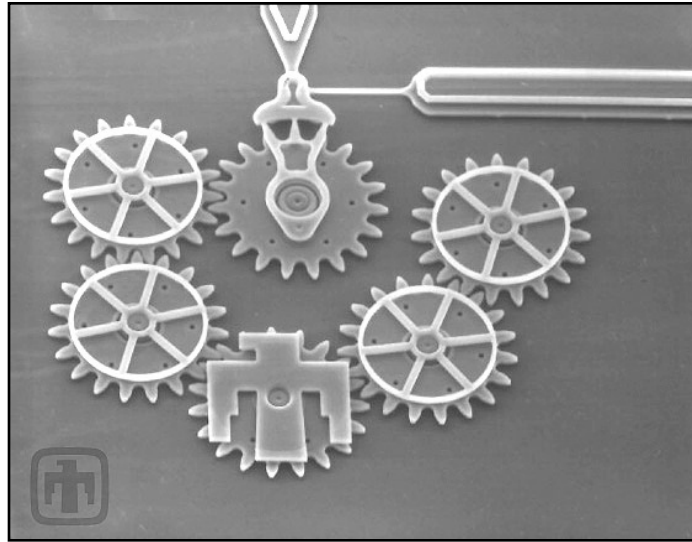

~ 1mm

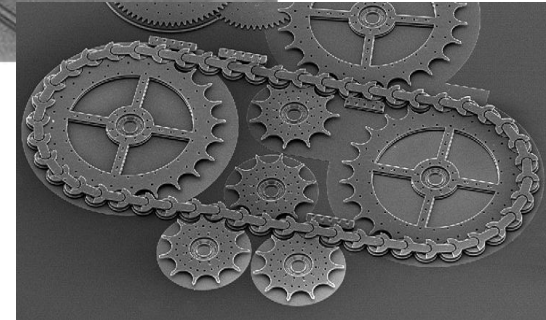
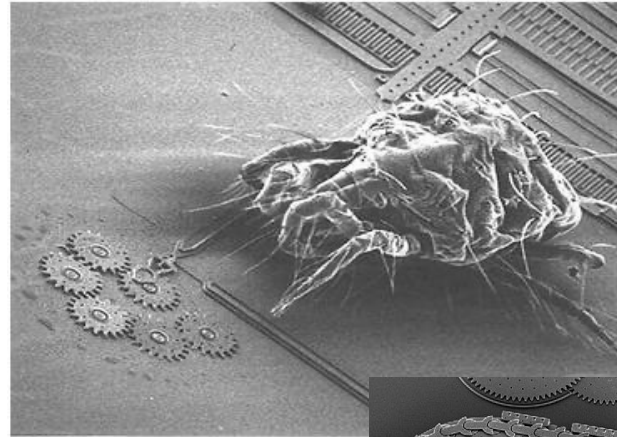

Senzori MEMS

Accelerometre, magnetometre, giroscopae, microfoane, difuzoare etc.

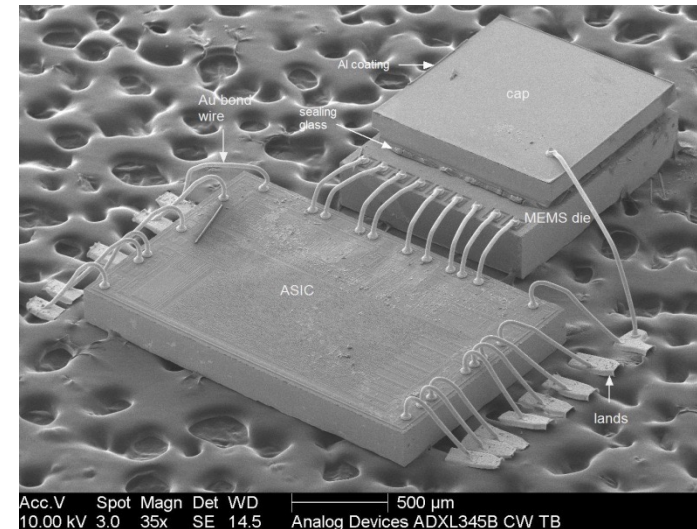
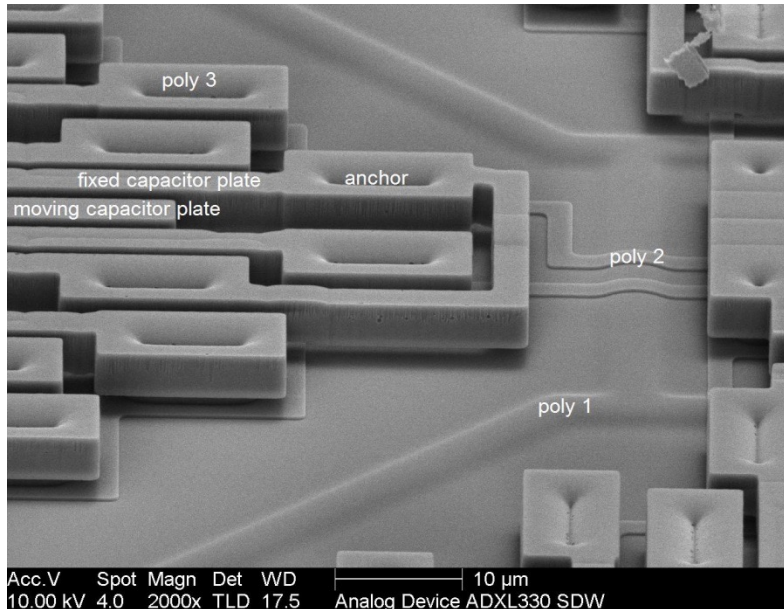

MEMS pentru Radiofrecvența

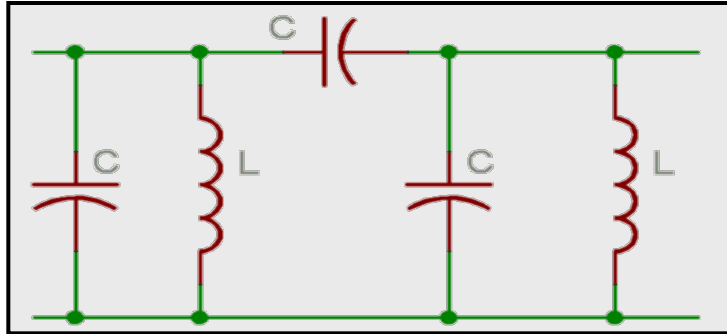

Filtru LC convențional – Q_s aprox.
100-200, ocupă spațiu pe PCB

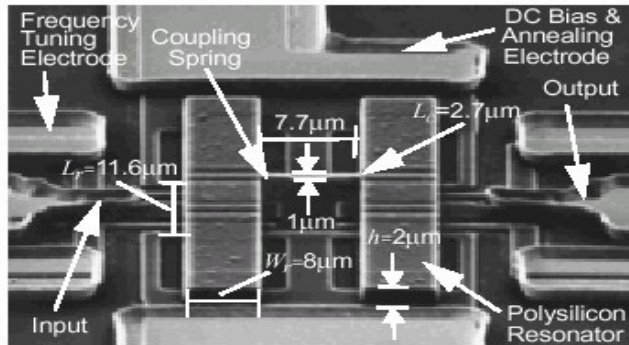
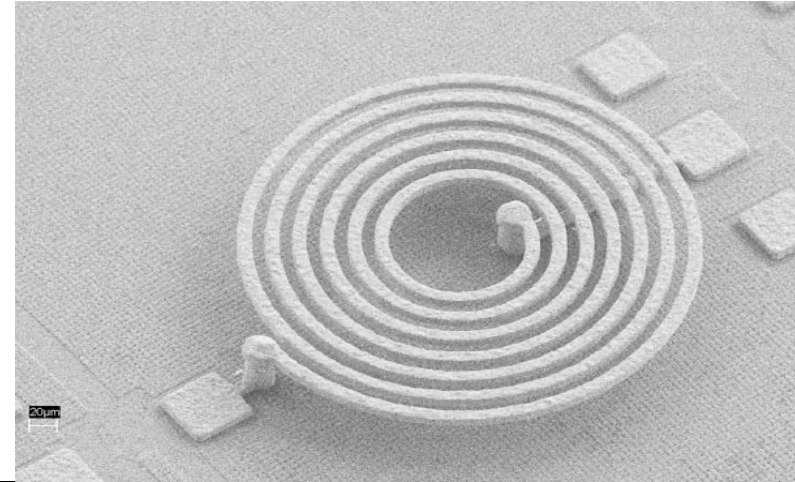

Filtru MEMS: Q_s de 98,000 în vid, dimensiuni
FOARTE mici

What is a Mote?

- **mote** *noun [C] LITERARY*
something, especially a bit of dust, that is so small it is almost impossible to see
---Cambridge Advanced Learner's Dictionary
<http://dictionary.cambridge.org/define.asp?key=52014&dict=CALD>

Evoluția platformei senzoriale hardware (Berkeley)

WeC 1/00



Rene 11/00



Mica 1/02



Mica2 9/02



Mica2dot 9/02



SPEC 5/03



Componentele unui nod

- Procesor low-power.
 - Putere de calcul limitată
- Memorie.
 - Capacitate limitată.
- Radio.
 - Low-power.
 - Viteza de transmisie mică.
 - Distanța de emisie redusă.
- Senzori.
 - Scalari: temperatură, lumină, etc.
 - Camere video, microfoane etc.
- Sursă de alimentare.

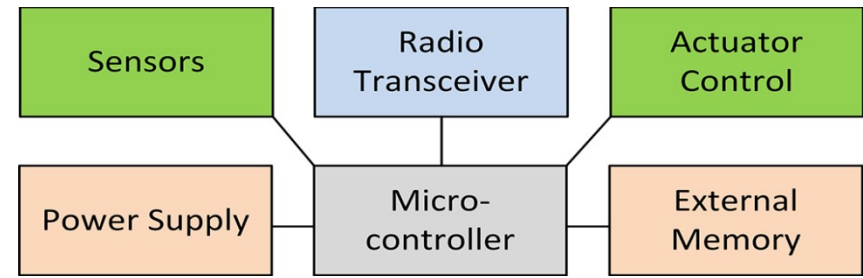

Comunicatia WSN

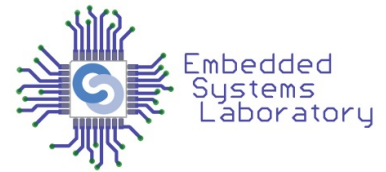

- Caracteristicile unui WSN tipic:
 - low data rate (comparabil cu un modem dial-up)
 - domeniu cu puternice constrângeri de energie
- **Standardul IEEE 802.11**
 - Cel mai răspândit pentru comunicația wireless
 - Poate fi întâlnit la primele rețele WSN, sau pentru noduri fără constrângeri stringente de energie
- **IEEE 802.15.4** este un standard pentru comunicația pe rază scurtă, proiectat special pentru rețelele WSN
 - low data rate
 - low power consumption
 - utilizare la scară largă în WSN academic sau soluții comerciale

Single-Hop versus Multi-Hop

- Topologie stea:
 - Fiecare senzor comunică direct (single-hop) cu base station
 - Poate necesita putere mare de transmisie și poate fi nefezabil pe o arie largă
- Topologie mesh
 - Sensorii au rol de **repetoare (forwarders)** pentru alte noduri (multi-hop)
 - Poate reduce consumul de energie și poate mări raza de acoperire
 - Apare problema **rutării**

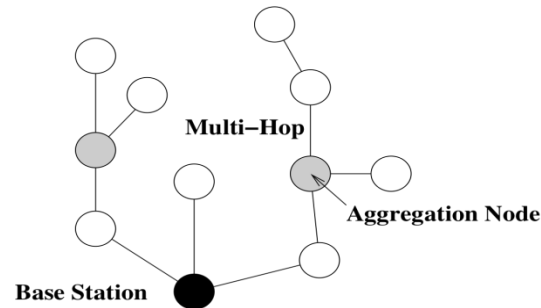
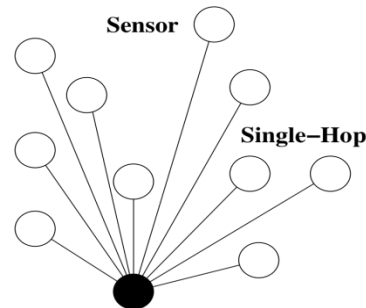

Exemple de noduri WSN

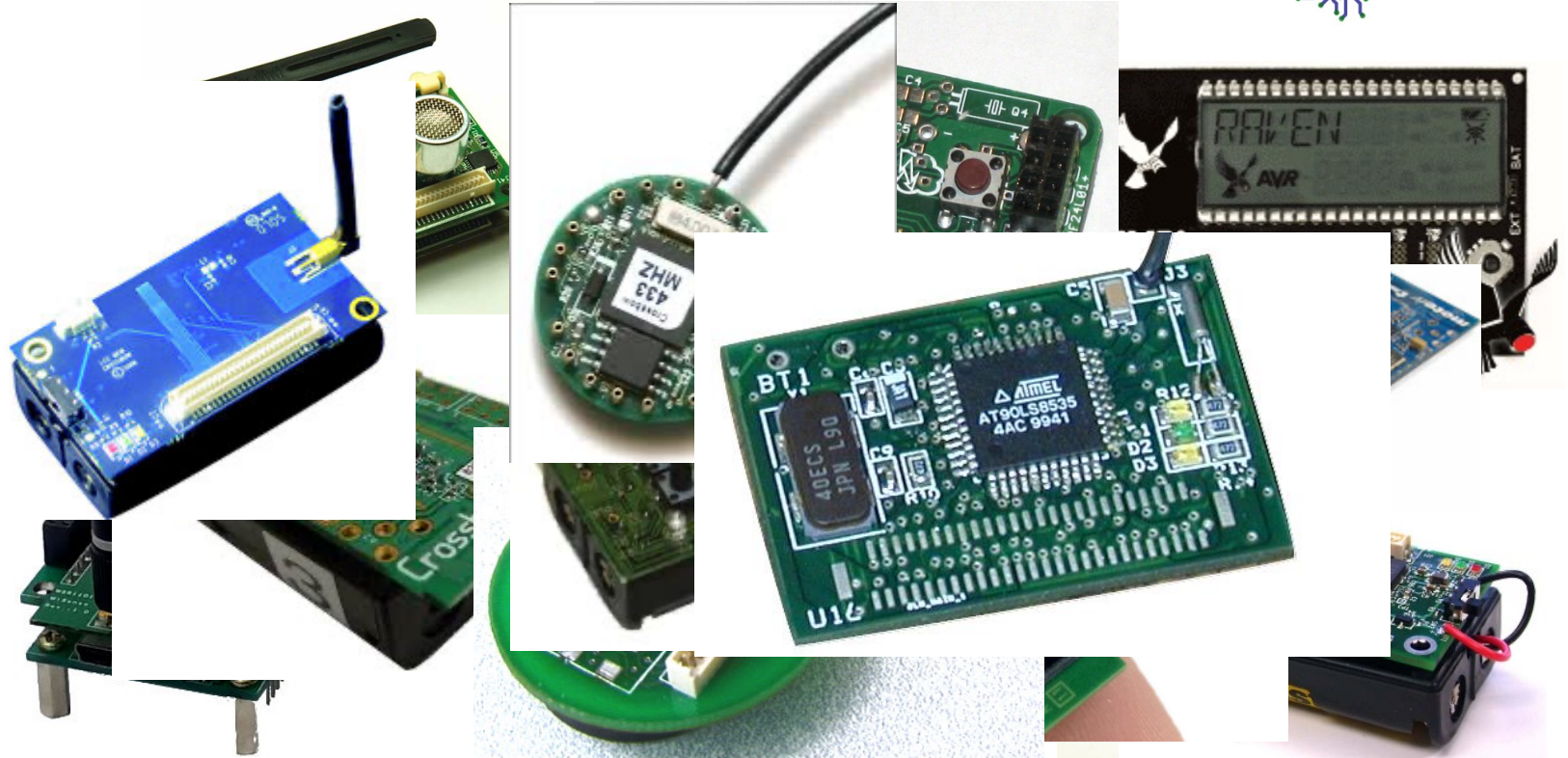

Exemplu: Sparrow

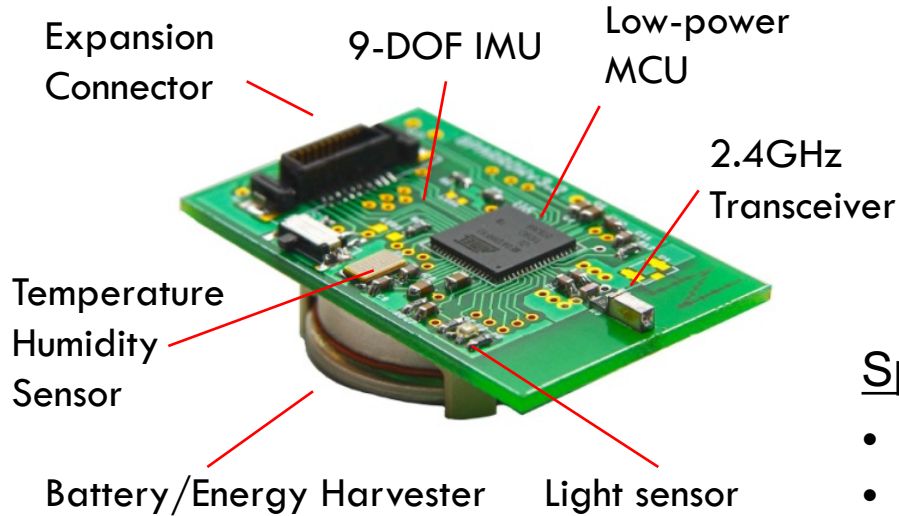

Standardul IEEE 802.15.4

Rata de transfer 256kbps

Specs:

- 16MHz
- 8KB RAM
- 128KB Flash
- ~ \$10
- 50mW, 36uW (sleep)
- 7g, 50x30x5mm
- 4.77MHz
- 16-256KB RAM
- 160KB Floppies
- ~ \$6,000
- ~ 64W
- 12kg, 500x140x400mm



- Sparrow - Wireless Sensor Network creată special pentru studiul energy harvesting
- Low-power (13mA Run-Time, 6uA Sleep)
- Poate rula o multitudine de sisteme de operare și stive de protocol

- Arduino compatible!
- Autonomie măsurată în ani de zile (4 years and still going strong)

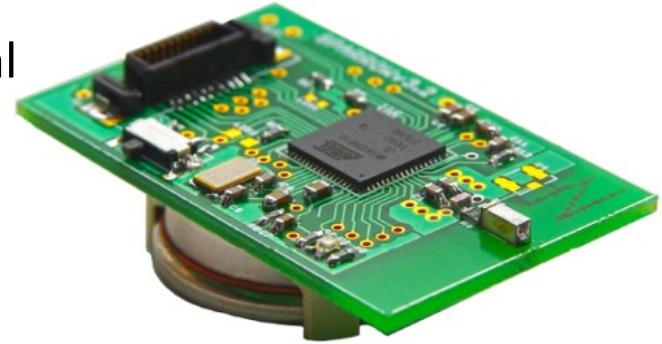

Technical specs

	Range
Humidity	Meas. interval: 0 ... 100 % Meas. error: $\pm 2\%$ RH
Luminosity	Meas. interval: 0...100000lux Visible & IR UV index
Temperature	Meas. Interval: $-40 \dots 100^{\circ}\text{C}$ Meas. error: $\pm 0.5^{\circ}\text{C}$

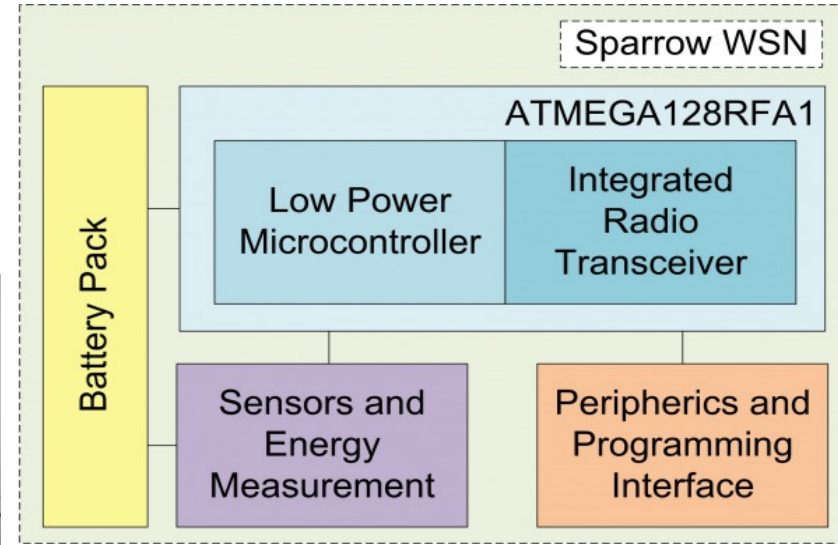
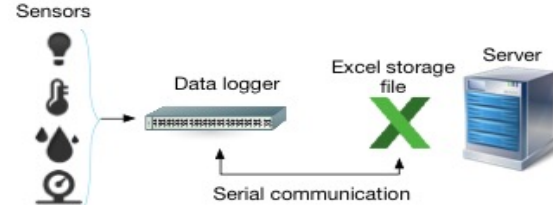

Deployment: Off-grid building

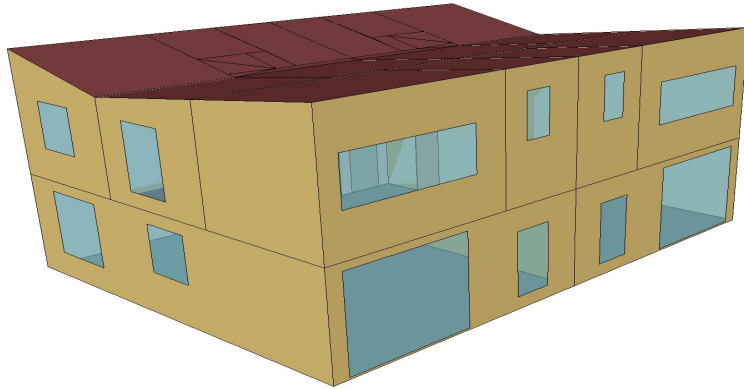

Floor plan

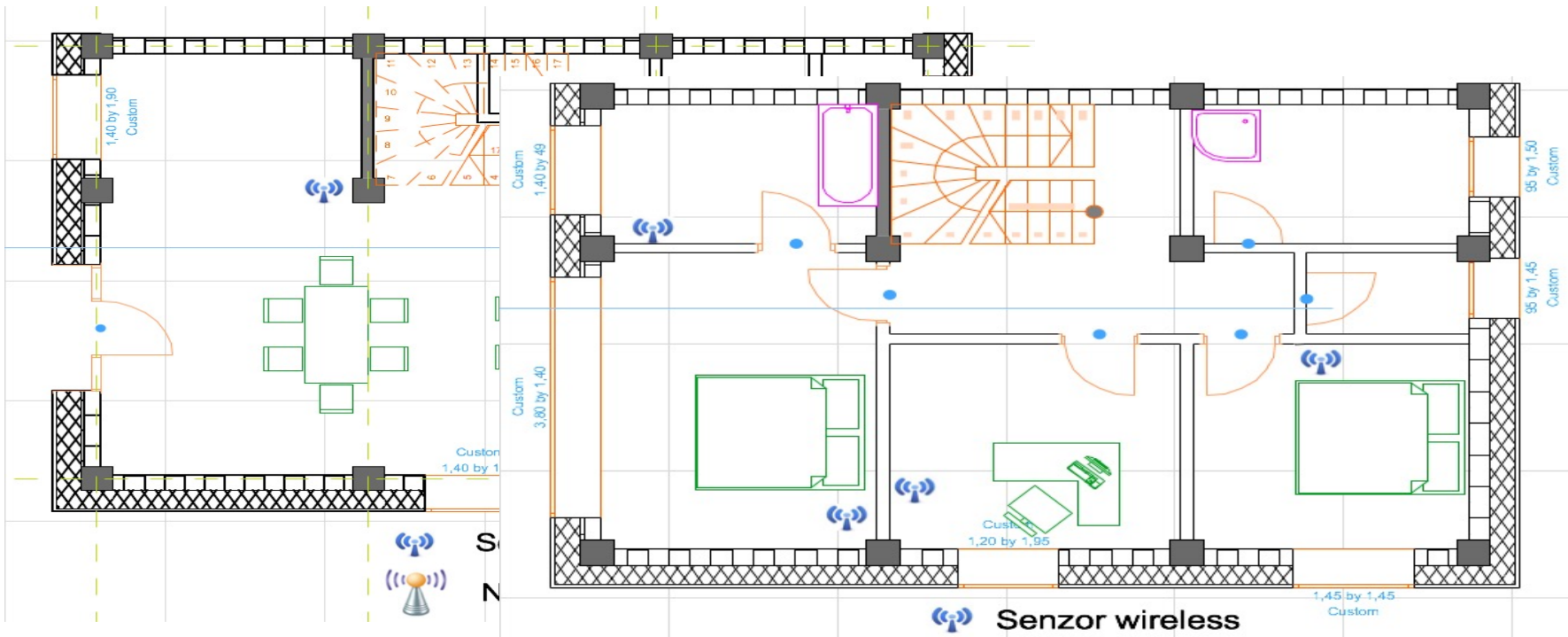

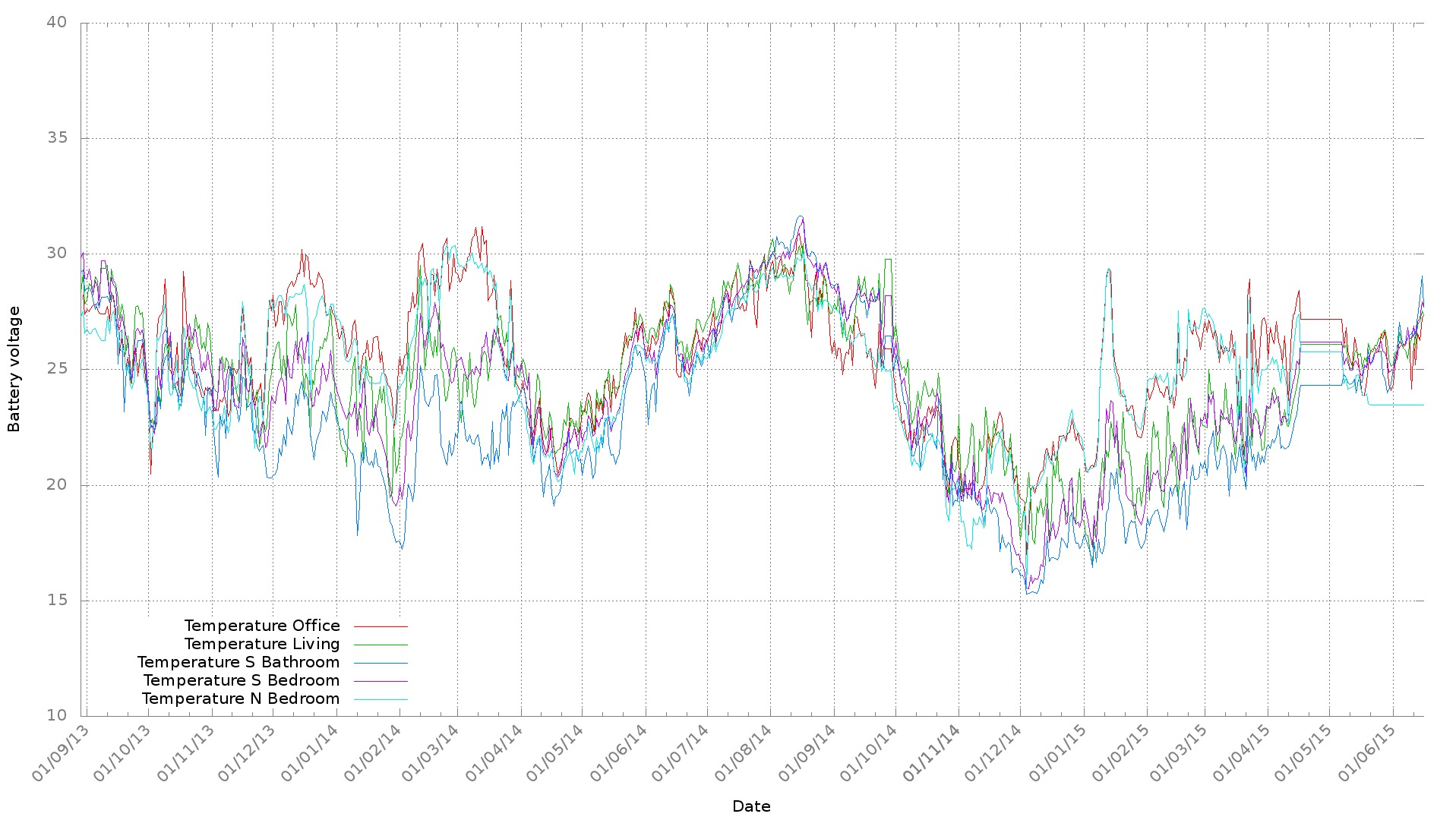

Energy-Independent Indoor WSN

Design care folosește energy harvesting

- Panou solar miniatură
- Convertor ultra low-power DC/DC
- Stocare în super-condensator
- Scalarea dinamică duty-cycle folosind algoritmi de esitmare a energiei
- Independență energetică totală pentru scenarii indoor/outdoor

20F Supercap

PV panel
with DC/DC
converter

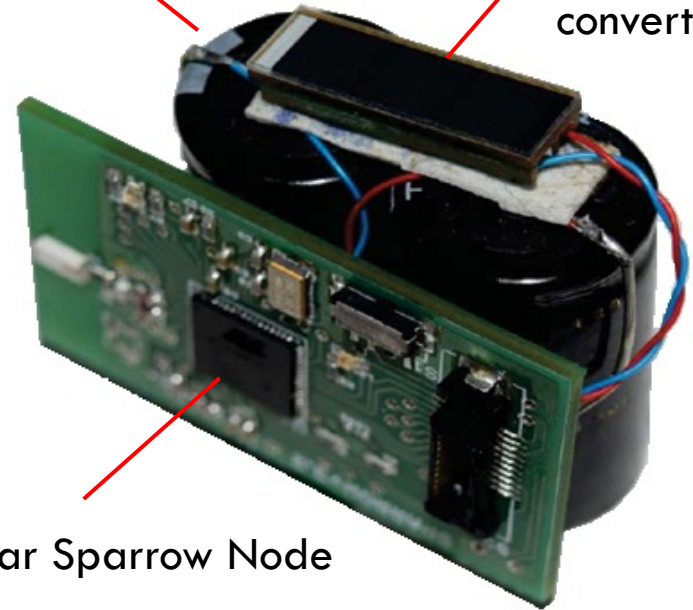

Regular Sparrow Node

Rezultate

2 1

400

Zoom

From To 

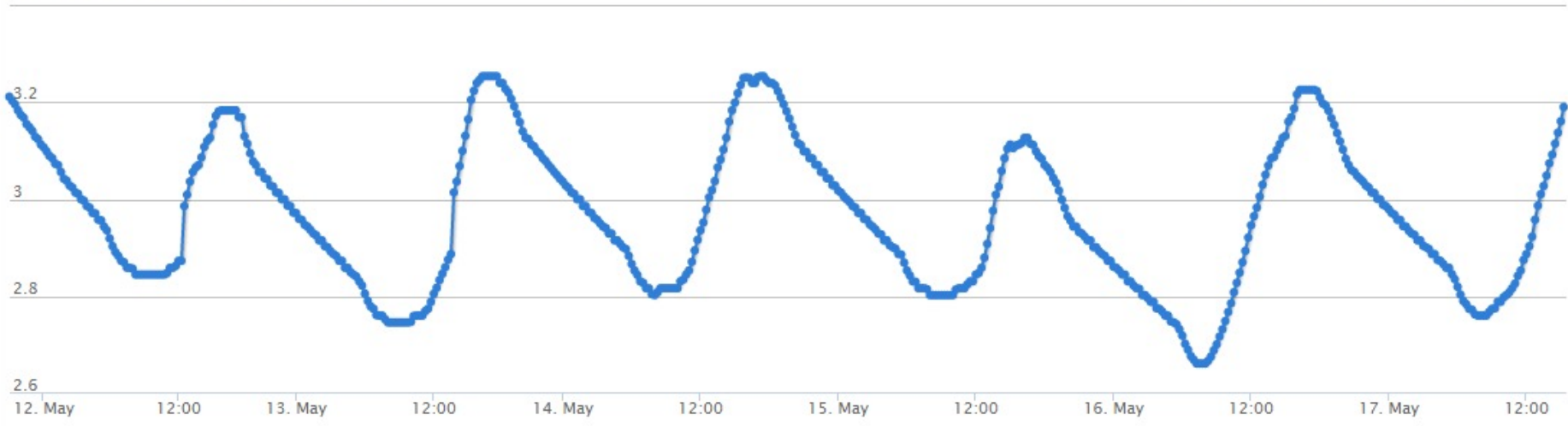

time

— Setup B, voltage - - - Setup B, sleep

Seismic Building Monitoring

- Interacțiunea dintre mișcările seismice și structura de rezistență a unei clădiri nu sunt bine înțelese sau modelate
- Rețelele seismice existente nu pot detecta deformările structurale ale unei clădiri

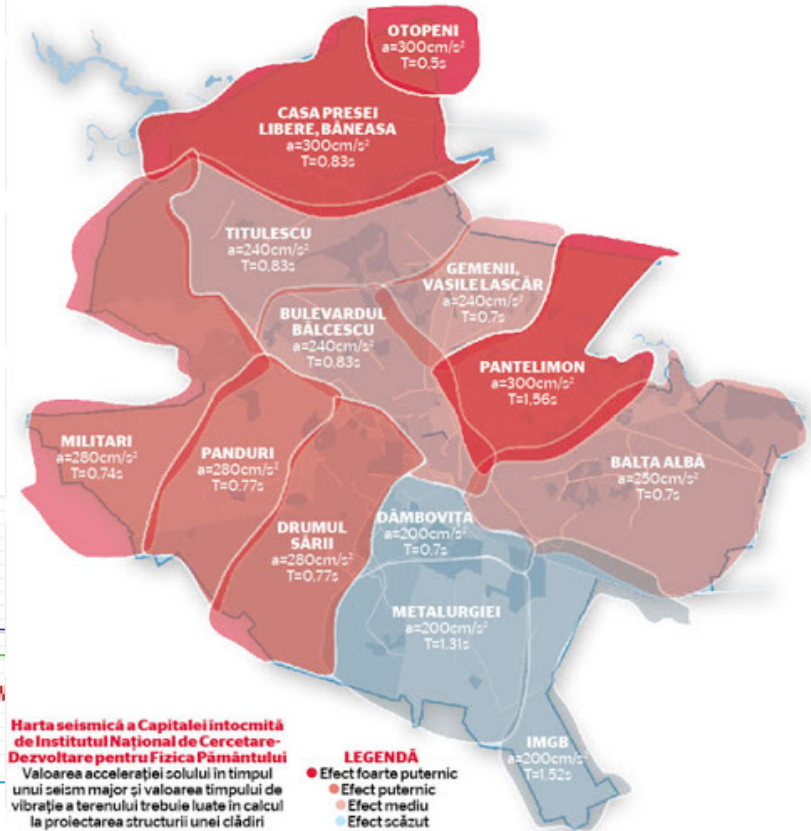
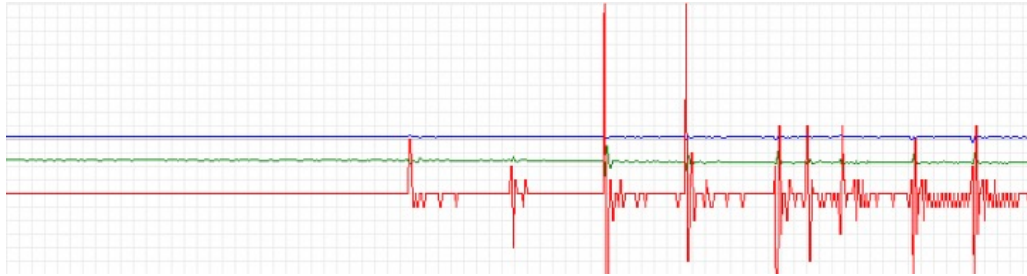

Descrierea sistemului

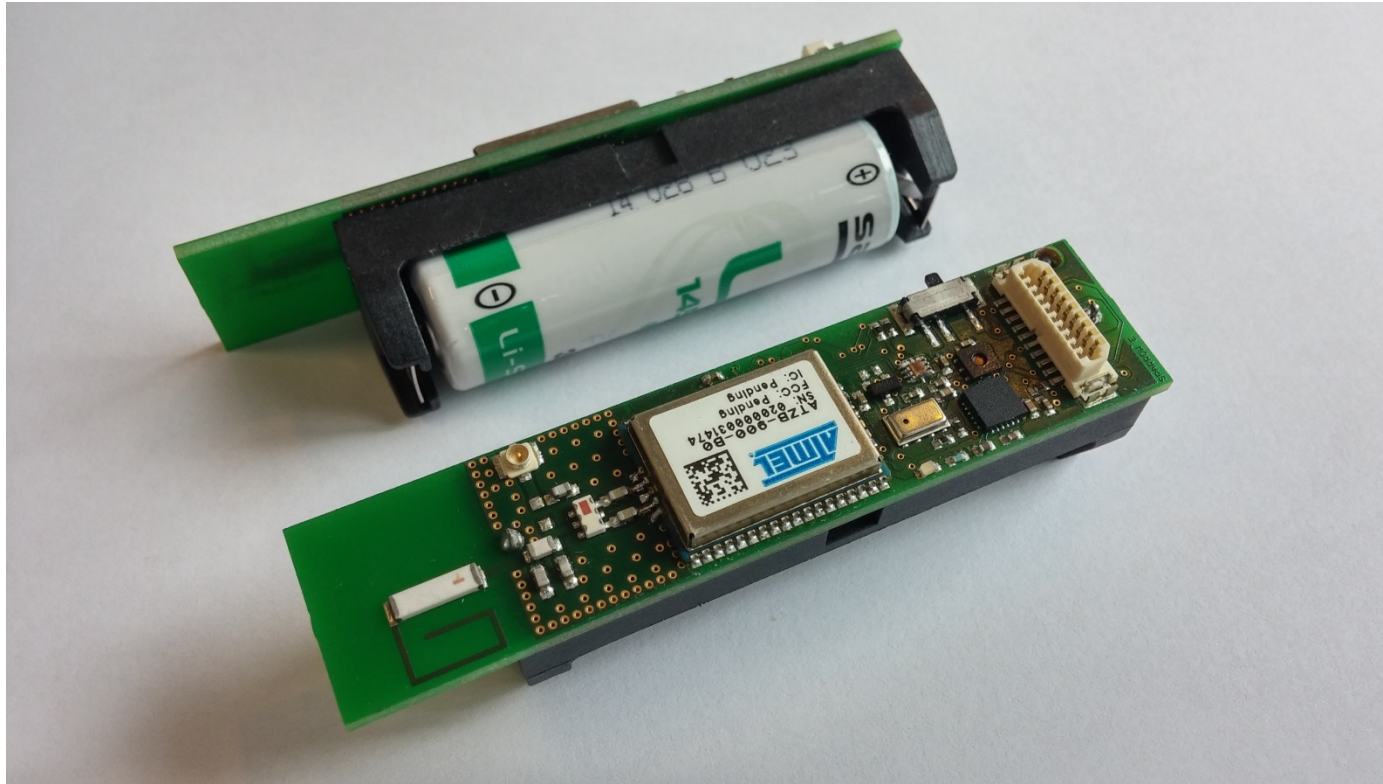

Rezulate

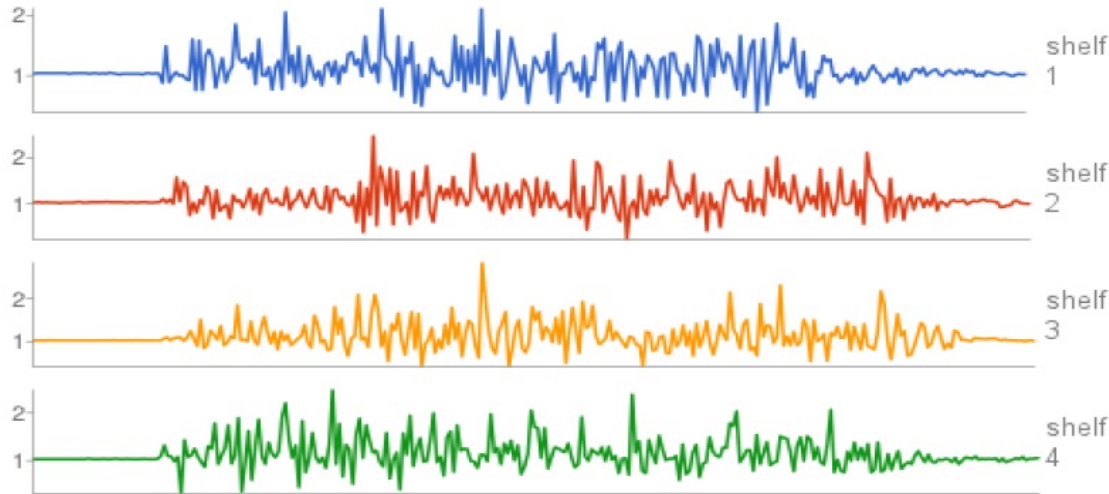

Microsal – Salivary Pacemaker

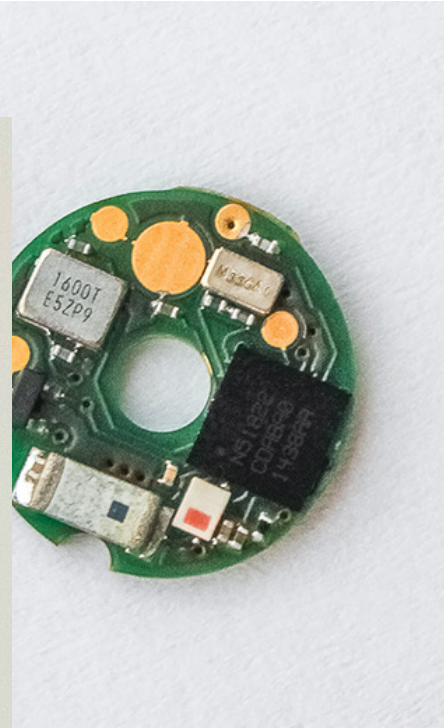
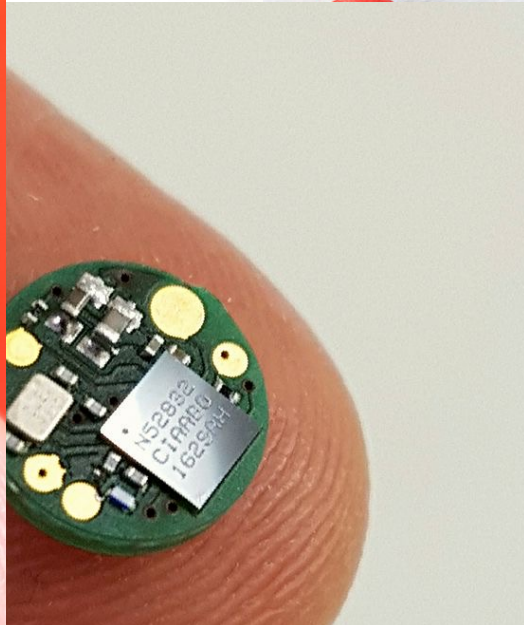
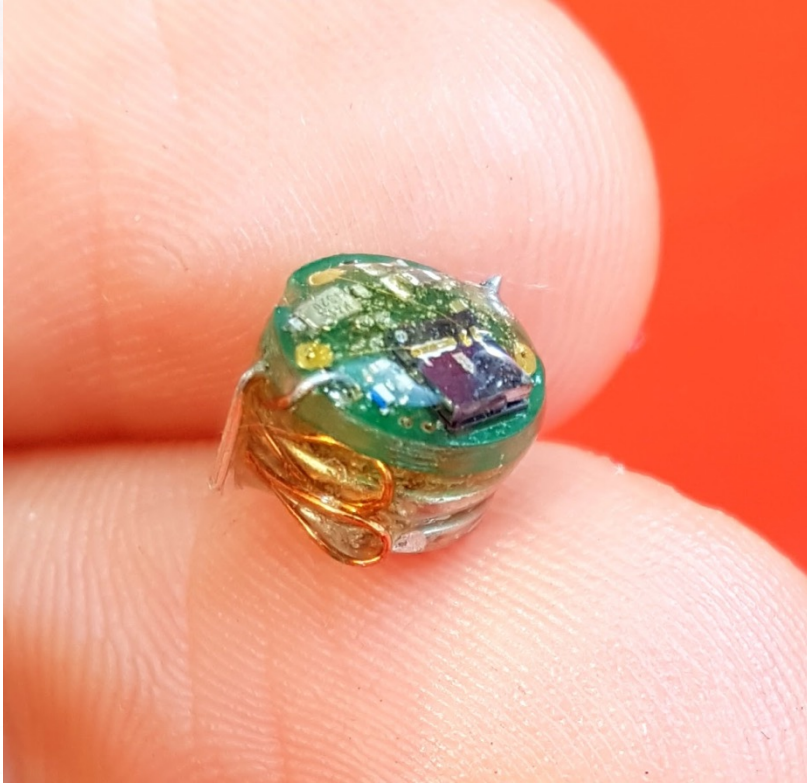

Thank you!

