

TimeLock Box – schema electrica

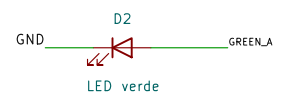
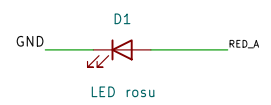
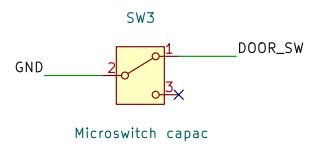
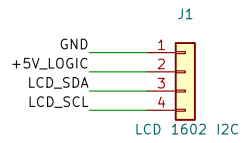
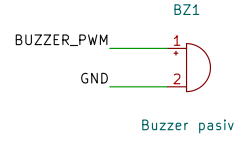
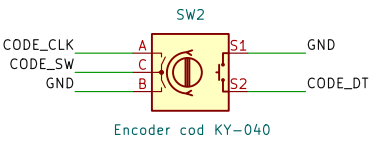
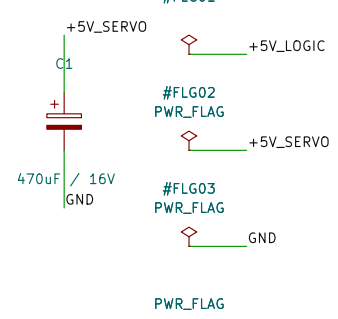
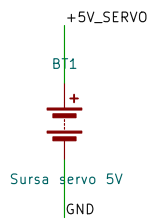
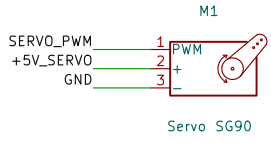
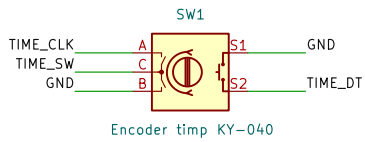
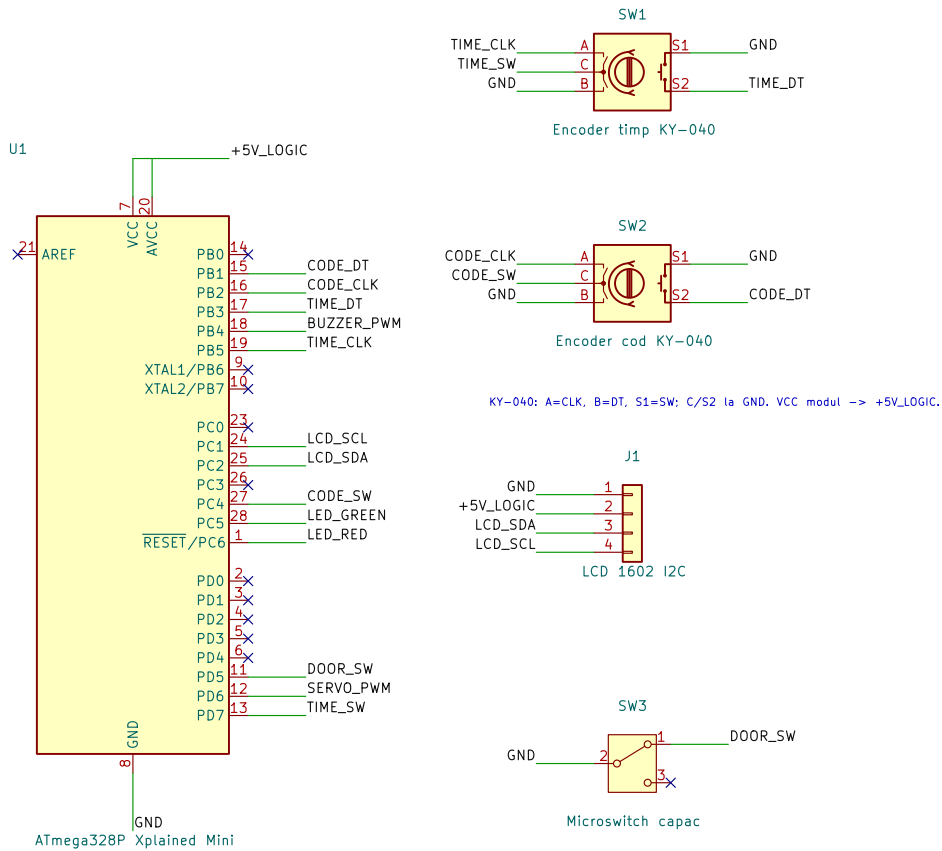

CODE_SW pe PC2/A2; PB3/MOSI ramane liber pentru SPI/shell.

PM	
Sheet: /	
File: TimeLock-Box.kicad_sch	
Title: TimeLock Box – schema electrica	
Size: A4	Date: 2026-05-16
KiCad E.D.A. 10.0.3	Rev: Milestone 2
	Id: 1/1