

Tetris Remake with motion controls

Name: Gradinariu Rares-Ioan

Grupa: Fils 1221A

Introduction

My project entails a motion-controlled Tetris game, leveraging an Arduino UNO R3 and other electronic components. My aim is to bring an innovative approach to a classic game and provide an enhanced interactive gaming experience for the user.

My idea stemmed from the desire to introduce a game-changing twist to Tetris and utilize motion control to add an extra dimension of interaction to the game. My inspiration for this project were two distinct gadgets, the fabled Nintendo Power Glove, and the tiny retro-like handheld, Playdate.

I believe that this project can prove valuable for others seeking to improve their programming and electronic engineering skills!



General Overview

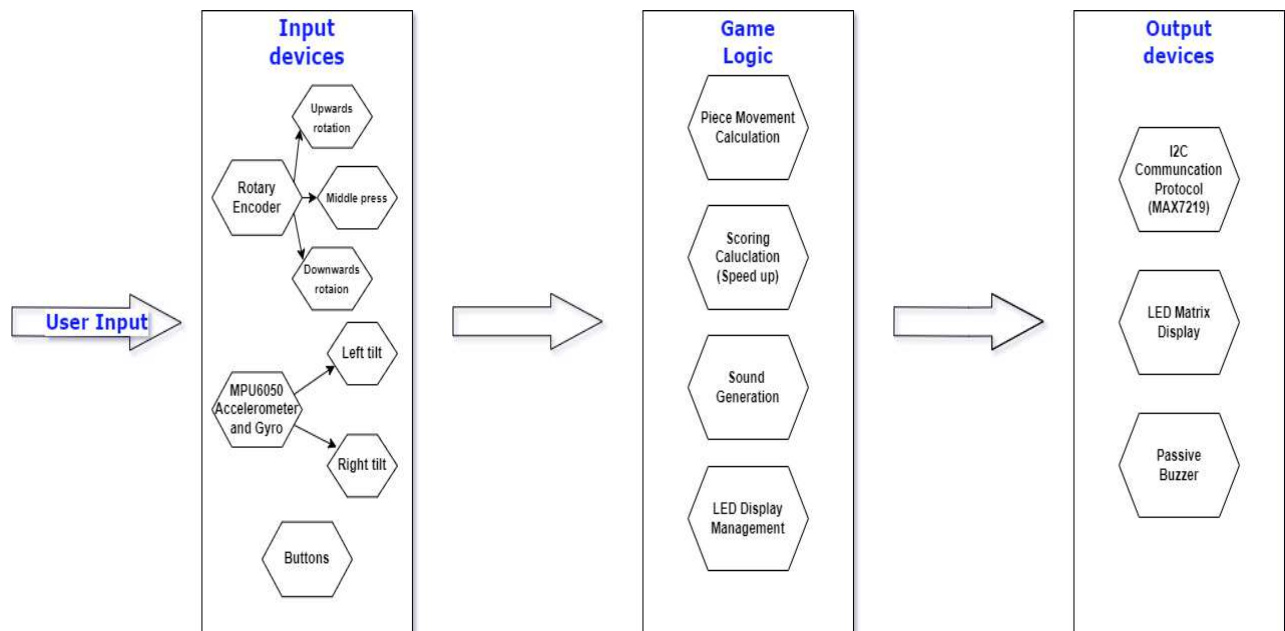

My project uses an open-source Tetris game clone code for Arduino, to which I added several changes. The visual part of this project is handled by two MAX7219 LED matrix modules (I2C). The software treats the display like a matrix, and each loop updates the piece's position accordingly to the user inputs and game rules. The Innovative part comes from the input methods. To make it more immersive, the player interacts with a Rotary Encoder. To rotate the piece, the player must rotate the lever upwards, and to speed it up, rotate it downwards as you would pull down the piece. The left and right movement is handled by an MPU6050 3-Axis Accelerometer and Gyroscope Module. The software part for it works directly with its address to assure the smallest input delay (No libraries). In addition, the player can choose to use the classic two-button combo to play the game if he desires it and wants to feel nostalgic. Naturally, the beloved Tetris song, "Korobeiniki", is also played here, thanks to a passive buzzer.

Hardware Design

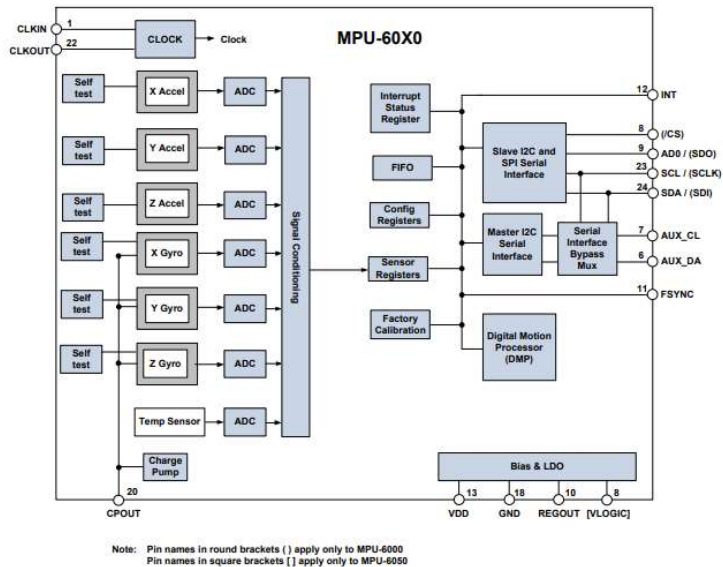

▪ Rotary Encoder Module

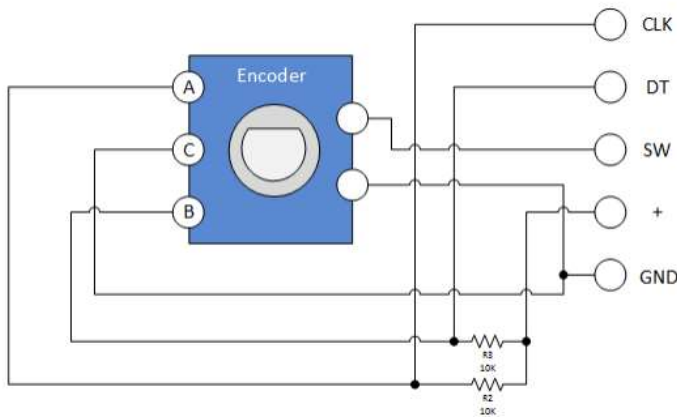

- Arduino UNO R3
- Push Buttons x2
- Passive Buzzer

Software Design

The program for my game was developed using the Arduino IDE. I utilized the following libraries and third-party sources:

- MAX7219 LedControl Library by Wayoda Eberhard Fahle
- Encoder Library by Paul Stoffregen
- Wire.h

The game code is based on the project by Badrinath Murugesan, also known as Electro Oxe. The musical composition for the game was created by Robson Couto.

Within my code, I implemented various algorithms and structures, including:

- Input handling for motion controls and calibration:

Motion controls are handled by two distinct functions, `calibrate()` and `tilt_to_button()`.

1. `calibrate()` takes 100 readings at the start of each game to compute the center-reference position. Calibration completion is signaled by a distinct beep, allowing the player to begin moving the console.

2. `tilt_to_button()` reads the X and Y coordinates and returns 0 for left, 1 for center, and 2 for right, taking into account a small dead zone to prevent incorrect inputs.
 - Menu system to start and reset the game.
 - Audio feedback using the passive buzzer.
 - General improvements to the code, such as adjusting delays and speed.

The source code and implemented functions are available in the project files. Links to the open-source projects used in this project are provided in the Bibliography section.

Rezultate Obținute

Care au fost rezultatele obținute în urma realizării proiectului vostru.

Concluzii

Download

Tetris with motion control - Source Code `gradinariu_rares_ioan_1221ea_tetris.txt`

Development Journal

- 28.03.2023

I started planning my new project. I want to create a handheld game console that uses motion controls to play games. Started Researching the hardware components and started looking for some ideas online.

- 01.04.2023

I decided to make a Tetris Remake and ordered all the necessary components for my project. I ordered an Arduino UNO R3, a MAX7219 LED matrix module, an MPU6050 accelerometer and gyroscope module, an encoder module, two buttons, and a passive buzzer. I also ordered some wires, resistors, and two mini breadboards for prototyping.

- 05.04.2023

I received all of my components today and spent time organizing them and reading the datasheets. I also started wiring up the components on a breadboard and testing their functionality.

- 10.04.2023

I started coding the software for my handheld console. Encounter some issues with the gyro, more research is needed.

- 20.04.2023

Continued with software development, Implemented some functionality for the Rotary encoder. Made some progress with the gyro functions

- 25.04.2023

I made some significant progress with the software today. I implemented a menu system to start and reset the game, added audio feedback using the passive buzzer, and improved the overall performance of the code. I still need to fine-tune the motion controls and adjust the delay and speed settings. Ended up not using any library for the Gyro as I was getting false positive information. Not reliable for my use-case scenario

- 30.04.2023

Finished the code and tested the game. It works pretty well and is super fun to play. I also had, some friends test it and received positive feedback.

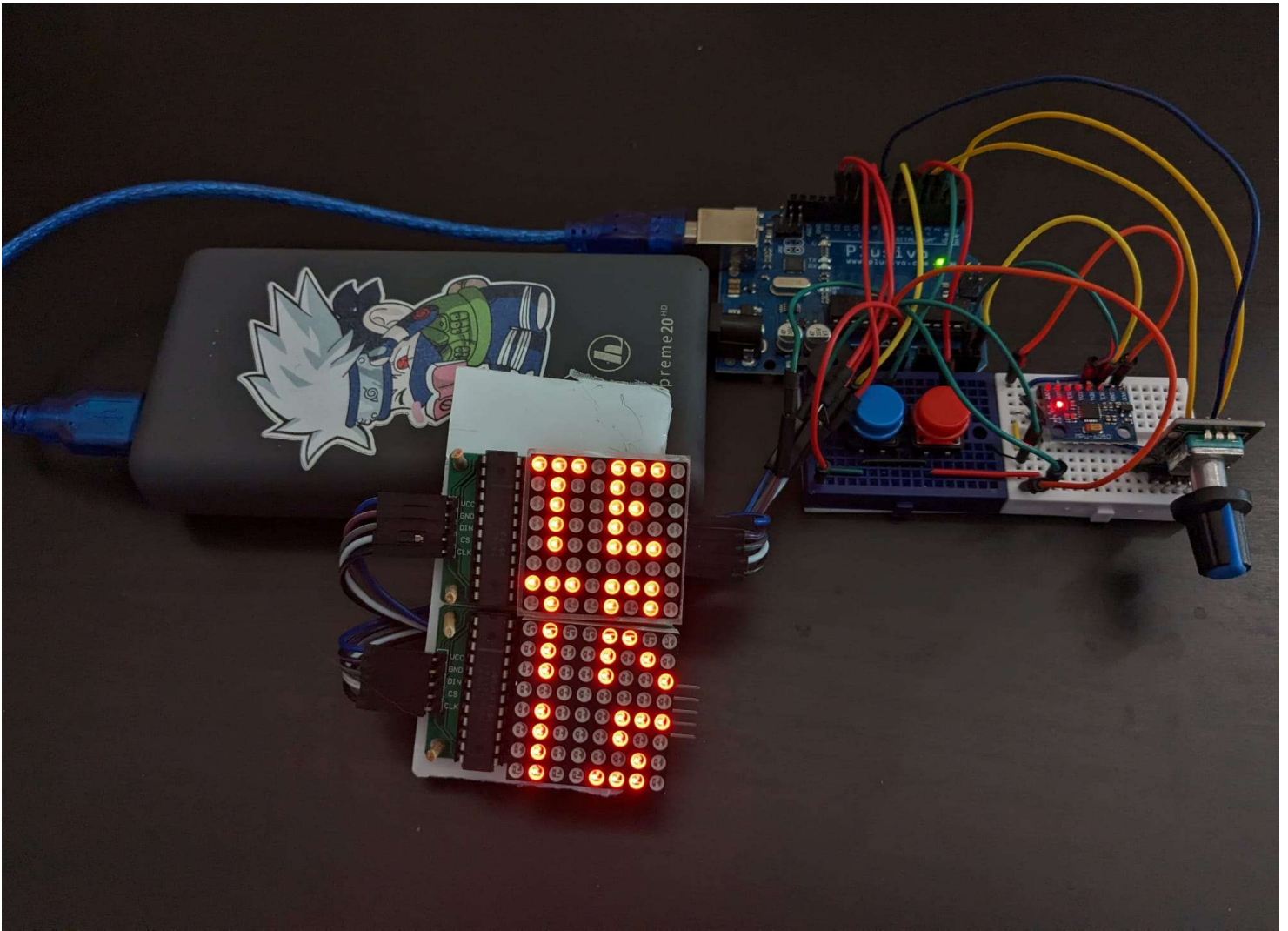

- 01.05.2023

I started working on the 3D model for the case of my handheld console. I'm using Tinkercad to design the case and trying to make it resemble a GameBoy DBG-01. It's challenging to fit all the components inside while keeping the case small.

- 03.05.2023

3D models are ready. I used Autodesk Netfabb, to solve any structural issues and improve the overall quality. I need to print out the design to make a fit test

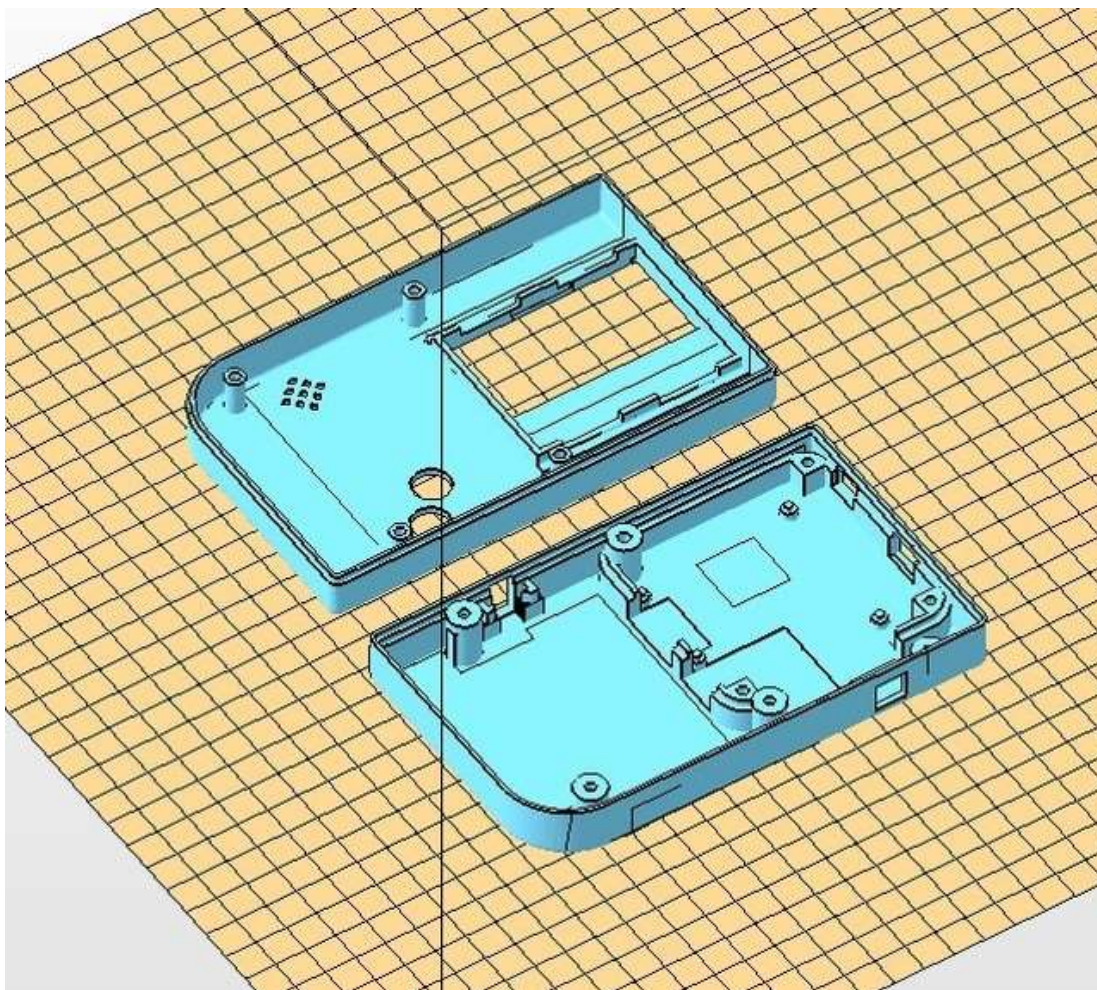

Bibliografie/Resurse

→Tetris source-code

https://github.com/viratbadri/Electro-oxe/blob/master/codes/ArduinoMatrix_Tetris.ino

→Tetris theme song

<https://github.com/robsoncouto/arduino-songs/blob/master/tetris/tetris.ino>

→MAX7219 LED Matrix Display Module -DataSheet- Handson Technology

<https://www.handsontec.com/dataspecs/module/MAX7219-4-In-1.pdf>

→MPU6050 3-Axis Accelerometer and Gyroscope Module -DataSheet- Invensense

<https://invensense.tdk.com/wp-content/uploads/2015/02/MPU-6000-Datasheet1.pdf>

→Rotary Encoder Module -DataSheet- Handson Technology

<http://handsontec.com/dataspecs/module/Rotary%20Encoder.pdf>

Export to PDF

pm/prj2023/apredescu/tetrisremake.txt · Last modified: 2023/05/06 12:59 by rares.gradinariu