



IOT & EDGE PROCESSING

NXP Strategic Engagements

Iosif Antochi

10 Mai 2023



PUBLIC



SECURE CONNECTIONS
FOR A SMARTER WORLD

Agenda

IoT - Internetul lucrurilor

- The Good
- The Bad
- The Ugly
- Sperante si Tendinte de viitor (MATTER & ChatGPT)

Edge Processing (procesarea la marginea retelei)

- Ce este si la ce foloseste EP?
- Exemple de EP implementate pe microcontrolere de la NXP

Intrebari



Iosif Who?

- 1995 - 2000: Facultatea de Automatica si Calculatoare, UPB - Romania
- 2001 - 2005: TUDelft - Olanda, Ph.D. in Electrical Engineering (Suitability of tile-based rendering for low-power 3D graphics accelerators)
- 2005 - 2017: Imagination Technologies Ltd. / PowerVR - UK, Leading Design Engineer
- 2017 - prezent: NXP Semiconductors SRL - Romania, Senior Engineer - Strategic Engagements



Antochi Iosif

IOT – THE GOOD



Hype cycle for Emerging Technologies 2017

Varful tehnologiilor emergente in 2017:

- Edge Computing
- Smart Robots
- IoT Platform
- Connected Home
- Deep Learning
- Machine Learning

Unde au ajuns aceste tehnologii in 2023?

Hype Cycle for Emerging Technologies, 2017

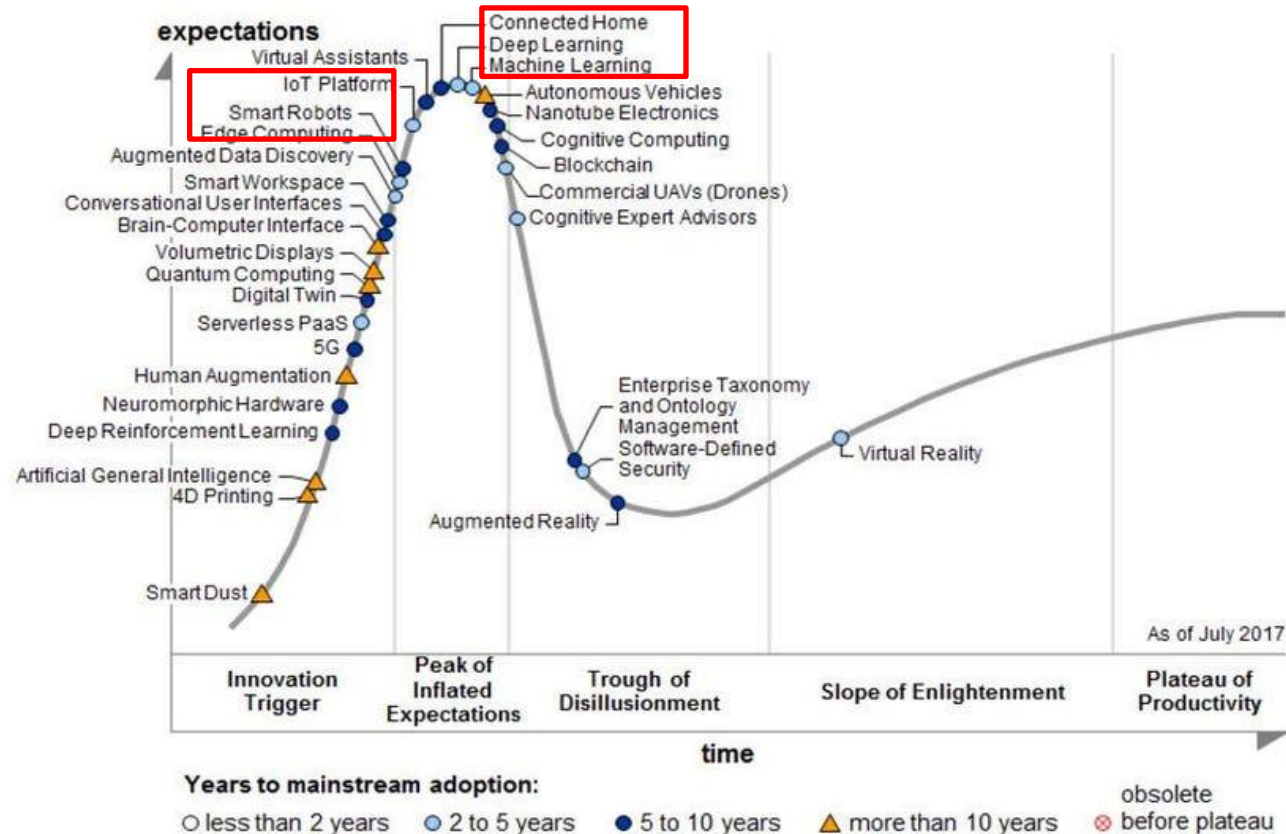

Note: PaaS = platform as a service; UAVs = unmanned aerial vehicles

Source: Gartner (July 2017)



Unde au ajuns tehnologiile emergente din 2017?



Sursa: <https://youtu.be/nwPtcqcqz00>

IOT – THE BAD



Situatia este complexa ...

- Integrarea dispozitivelor in retele IoT
 - O multitudine de standarde si protocoale ce trebuiesc implementate pentru a interactiona cu dispozitive de la alti producatori.
- (In)securitatea in retelele IoT (Cum protejam dispozitivele IoT) ?
 - Actualizare firmware
 - Firewall
 - Comunicare securizata

Securitatea dispozitivelor IoT este o componenta care trebuie proiectata de la inceput si nu adaugata ca un accesoriu!

IOT – THE UGLY

Situatia este complexa ... (cont)

- Confidentialitate si intimitate:
 - Ce se intampla cu datele culese de la senzori dupa ce ajung in “cloud”?.
EU - GDPR, OTHERS?
- Cum sunt intretinute/actualizate dispozitivele IoT?
 - Actualizarea de firmware in practica este mai mult exceptia decat norma.
De evitat componente conectate pentru care nu exista un plan de actualizare de firmware.
- Ce se intampla cu produsele IoT pentru care producatori au dat faliment sau nu le mai suporta?
 - Mai pot fi accesate datele si serviciile din cloud?

IOT – NOI SPERANTE / DIRECTII

There is still hope

What is Matter?

- Matter (formerly Project Connected Home over IP, or Project CHIP) is a new Working Group within the Connectivity Standards Alliance (CSA, formerly Zigbee Alliance). This Working Group plans to develop and promote the adoption of a new, royalty-free connectivity standard to increase compatibility among smart home products, with security as a fundamental design tenet.
- The goal of the Matter project is to simplify development for manufacturers and increase compatibility for consumers. The project is built around a shared belief that smart home devices should be secure, reliable, and seamless to use. By building upon Internet Protocol (IP), the project aims to enable communication across smart home devices, mobile apps, and cloud services and to define a specific set of IP-based networking technologies for device certification.
- The CSA officially opened the Matter Working Group on January 17, 2020.
- Visit buildwithmatter.com to learn more and read the latest news and updates about the project.
- Matter officially launched in November 2022.

Sursa: <https://github.com/project-chip/connectedhomeip#readme>

Resurse Matter NXP:

<https://www.nxp.com/applications/enabling-technologies/connectivity/matter:MATTER?tid=vanmatter>

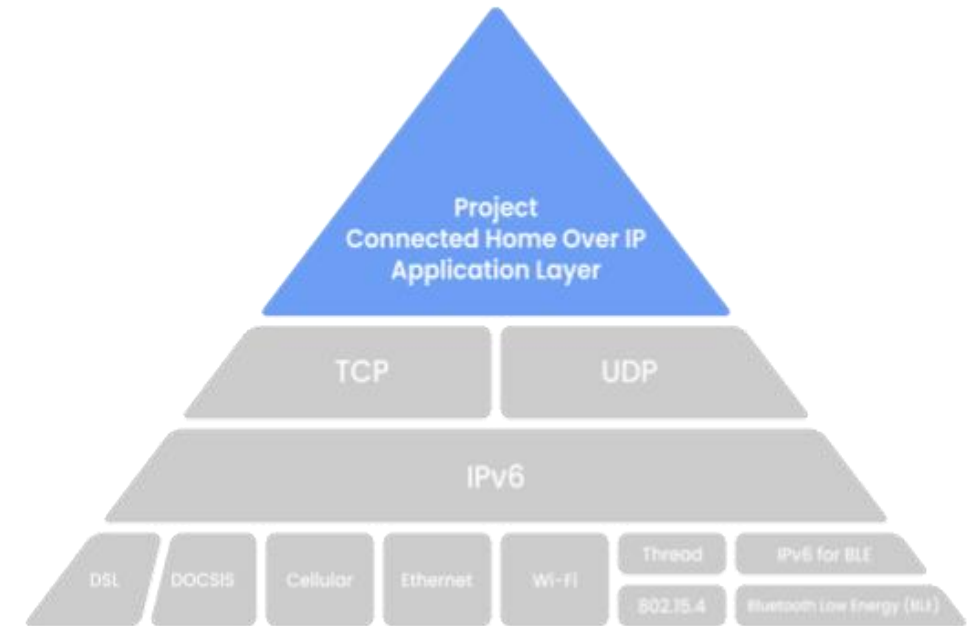

ChatGPT

Ce este chat GPT?

Generative Pre-trained Transformers (GPTs) – modele de ML folosite pentru procesarea limbajului natural.

Aceste modele sunt pre-antrenate pe seturi de date foarte mari (pagini web, colectii de carti) si pot genera texte coerente semantic si cu continut relevant pentru contextul abordat.

The Good:

- Poate genera texte foarte relevante si credibile (inclusive aplicatii)

The Bad:

- Poate suferii de halucinatii

The Ugly:

- Este folosit deja pentru a scrie Malware.



Resurse GPT:

OpenAI: <https://openai.com/>

Scurta prezentare a versiunilor GPT:

<https://www.makeuseof.com/gpt-models-explained-and-compared/>

OpenAI's GPT-4: A 70-Year Old Lesson!:

<https://youtu.be/5kBu7z7Ye7M>

Sparks of Artificial General Intelligence: Early experiments with GPT-4:

<https://arxiv.org/abs/2303.12712>

EDGE PROCESSING (PROCESAREA LA MARGINEA RETELEI)

Edge Processing

Procesarea la marginea rețelei constă în acțiunea de procesa datele cât mai aproape de sursă și nu într-un centru de procesare îndepărtat (cloud).

Această procesare este favorizată pentru:

- Reducerea latenței
- Reducerea volumului datelor transmise către cloud
- Reducerea costului cu dispozitivele din cloud
- Prin procesare locală se poate obține și o mentinere mai bună a confidențialității

Posibile dezavantaje:

- Necesită putere de calcul sporită la sursă
- Poate necesita senzori mai scumpi.

MCU vs. MPU



	MicroController (Embedded Processor)	MicroProcessor (Application Processor)
Applications	Switches, Appliances, Power tools, Toys, etc.	Smart phones & tablets, Smart screens, Routers/gateways, Robo-cleaners, etc.
Graphics	None, or basic bit mapped	Complex UI
Operating System	FreeRTOS, MicroC/OS, Mbed OS, ...	Linux, Android, iOS, Windows, ...
Virtual Memory Support	No	Memory Management Unit
Storage	Mega Bytes (NOR Flash – often on chip)	Giga Bytes (NAND Flash)
Memory	Mega Byte (SRAM – usually all on chip)	Giga Bytes (SDRAM)
CPU	ARM Cortex-M	Arm Cortex-A
Number of cores	1 (or 2)	1, 2, 4, 8, ...
NXP Example Family	i.MX RT1060	i.MX 8M



More detailed MCU examples

- **Lower end - Atmel/Microchip ATtiny family:**

- ATtiny25: 8-Bit AVR architecture, 2KB Flash, 128B SRAM, 128B EEPROM, 2 Timers, 20Mhz, 8 Pins!

<https://www.microchip.com/wwwproducts/en/ATtiny25>

- **Low end - Atmel/Microchip ATmega family:**

- ATmega328p: 8-Bit AVR architecture, 32KB Flash, 2048B SRAM, 1024B EEPROM, 3 Timers, 16 MIPS, 32 Pins

<https://www.microchip.com/wwwproducts/en/ATmega328P>

Other notable (used in Arduinos) members of the ATmega family: ATmega8, ATmega168, ATmega1280, and ATmega2560

- **Mid range - NXP Kinetis family:**

- KW41Z: 32-Bit ARM Thumb-2 architecture, Cortex-M0+, BLE 4.2 & 802.15.4, 48MHz Cortex-M0+, 256KB Flash, 64KB RAM, 48 Pins

<https://www.nxp.com/products/wireless/thread/kinetis-kw41z-2-4-ghz-dual-mode-bluetooth-low-energy-and-802-15-4-wireless-radio-microcontroller-mcu-based-on-arm-cortex-m0-plus-core:KW41Z>

- **Mid-upper range - Espressif ESP family**

- ESP32 (and older less secure ESP8266) Xtensa 32-bit L106, LX6, LX7 80-240 Mhz

<https://maker.pro/esp8266/tutorial/a-comparison-of-the-new-esp32-s2-to-the-esp32>

- **High end - NXP RT family:**

- RT1062: 32-Bit ARM Thumb-2 architecture, Cortex-M7, 0KB Flash, 1024KB SRAM (512KB TCM), 528-600Mhz, 196 Pins

- RT1064: Similar with RT1062 with added 4KB Flash

<https://www.nxp.com/products/processors-and-microcontrollers/arm-microcontrollers/i-mx-rt-crossover-mcus/i-mx-rt1060-crossover-mcu-with-arm-cortex-m7-core:i.MX-RT1060>

- RT1170: 32-Bit ARM Thumb-2 architecture, Cortex-M7 @ **1 GHz** + Cortex-M4 @ 400 MHz, 2 MB SRAM with 512 KB of TCM for Cortex-M7 and 256 KB of TCM for Cortex-M4, 289 Pins

<https://www.nxp.com/products/processors-and-microcontrollers/arm-microcontrollers/i-mx-rt-crossover-mcus/i-mx-rt1170-first-ghz-crossover-mcu-with-arm-cortex-m7-and-cortex-m4-cores:i.MX-RT1170>



i.MX RT Series Crossover MCUs

Applications Processors Performance + MCU Usability

2X
PERFORMANCE

2X
BATTERY LIFE

2X
INTEGRATION

2X
FASTER DEVELOPMENT

1/2
THE COST





Key Features

Product	CPU	Package	Memory	Graphics Acceleration	Display Interfaces	Camera Interfaces	Audio	USB with PHY	Ethernet	CAN
i.MX RT1170 >	Cortex-M7 @1 GHz + Cortex-M4 @400 MHz	289 BGA	2MB SRAM	2D GPU, PxP	Parallel, MIPI	Parallel, MIPI	4x I2S, SPDIF, DMIC	2	2x Gbps, 1x10/100	3x CANFD
i.MX RT1064 >	Cortex-M7 @600 MHz	196 BGA	4MB Flash 1MB SRAM	PxP	Parallel	Parallel	3x I2S, SPDIF	2	2x 10/100	2x FlexCAN, 1x CANFD
i.MX RT1060 >	Cortex-M7 @600 MHz	196 BGA	1MB SRAM	PxP	Parallel	Parallel	3x I2S, SPDIF	2	2x 10/100	2x FlexCAN, 1x CANFD
i.MX RT1050 >	Cortex-M7 @600 MHz	196 BGA	512 kB SRAM	PxP	Parallel	Parallel	3x I2S, SPDIF	2	1x 10/100	2x FlexCAN
i.MX RT1020 >	Cortex-M7 @600 MHz	100 LQFP 144 LQFP	256 kB SRAM	-	-	-	3x I2S, SPDIF	1	1x 10/100	2x FlexCAN
i.MX RT1015 >	Cortex-M7 @500 MHz	100 LQFP	128 kB SRAM	-	-	-	3x I2S, SPDIF	1	-	-
i.MX RT1010 >	Cortex-M7 @500 MHz	80 LQFP	128 kB SRAM	-	-	-	2x I2S, SPDIF	1	-	-
i.MX RT600 >	Cortex-M33 @300 MHz + Cadence® Tensilica® HiFi 4 @600 MHz	176 VFBGA	4.5 MB SRAM	-	-	-	DMIC	1	-	-

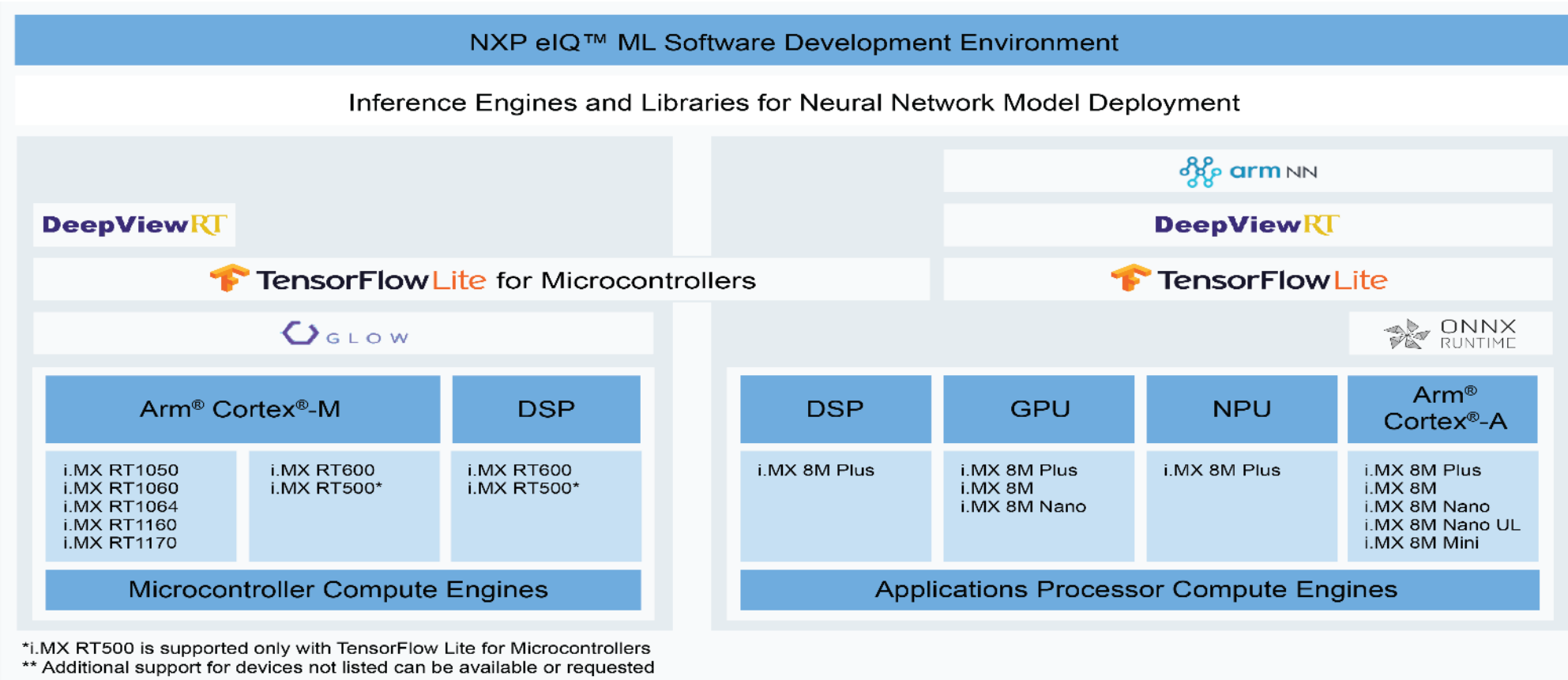

NXP eIQ (edge Intelligence) Software Ecosystem



NXP Technology

Resurse:

- <https://www.nxp.com/design/software/development-software/eiq-ml-development-environment:EIQ>
- <https://www.nxp.com/design/training/machine-learning-at-the-edge-and-eiq-ml-software-introduction:TIP-CONNECTS2021-ENT446>



GLOW FRAMEWORK OVERVIEW

eIQ FOR GLOW NEURAL NETWORK COMPILER

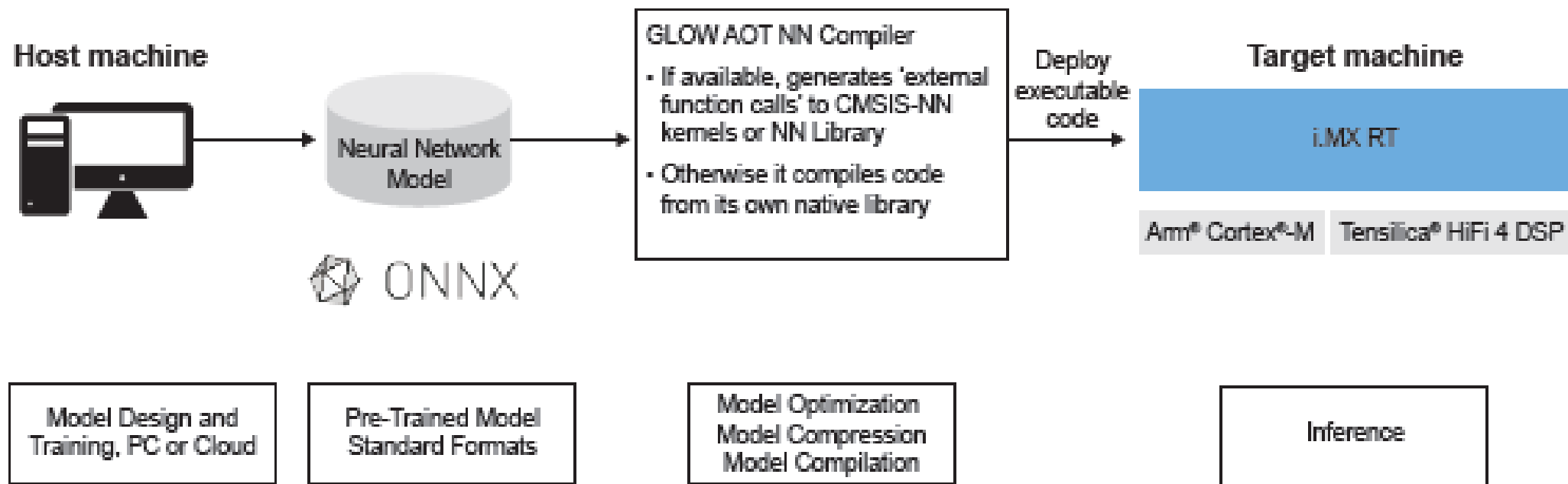

i.MX RT1170 Crossover MCU Block Diagram

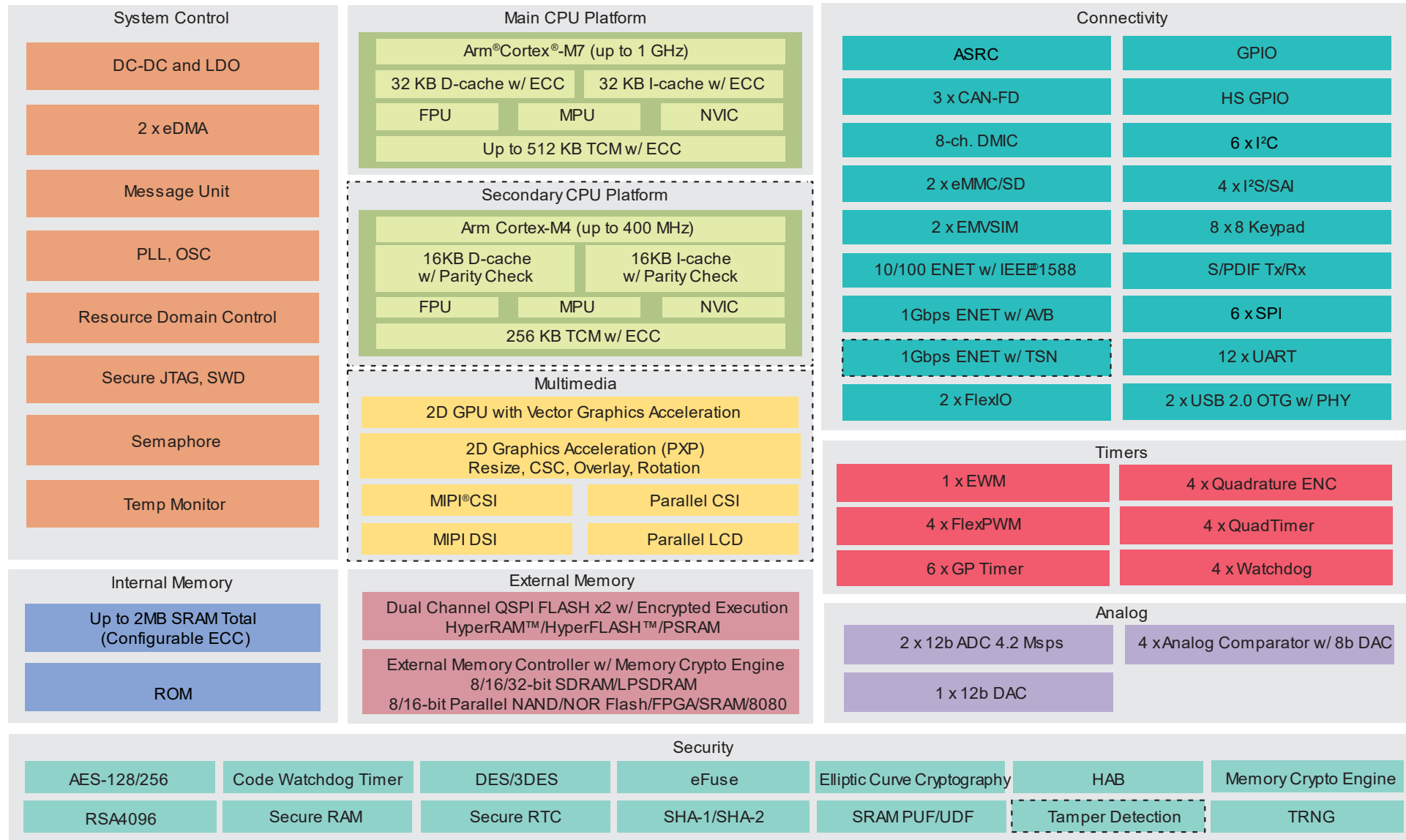

Available on certain products within the family



App SW Pack | ML State Monitor

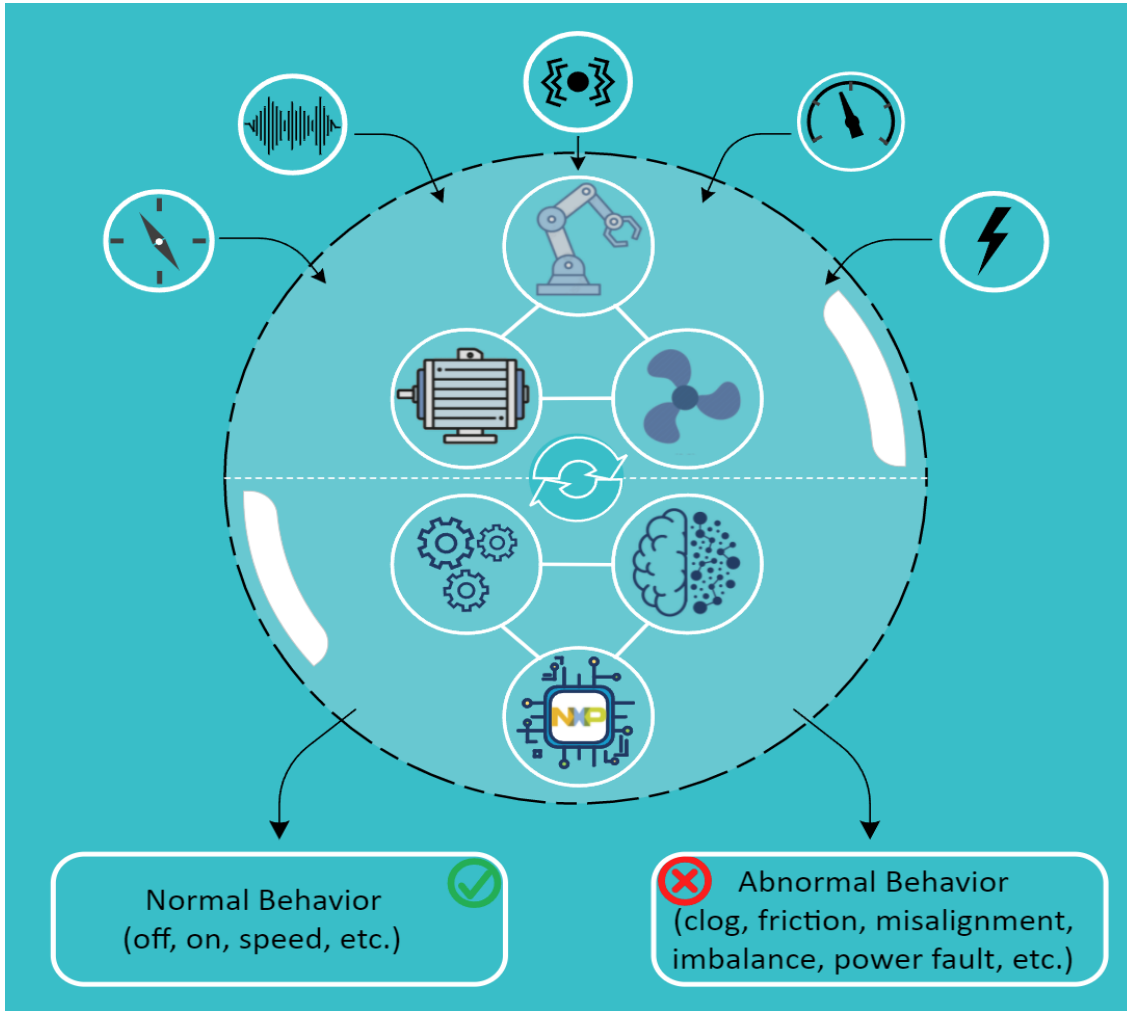

<https://www.nxp.com/design/software/embedded-software/application-software-pack-ml-state-monitor:APP-SW-PACK-ML-STATE-MONITOR>

Goal: Build ML-based Smart Sensing Appliances

How: Relies on Deep Learning and enables developers to build, deploy and benchmark Neural Networks on NXP's MCU-based systems for developing Smart Sensing Appliances.

Related application spaces: System state monitoring, Activity recognition, Machine health (preventive maintenance, anomaly detection, failure identification)

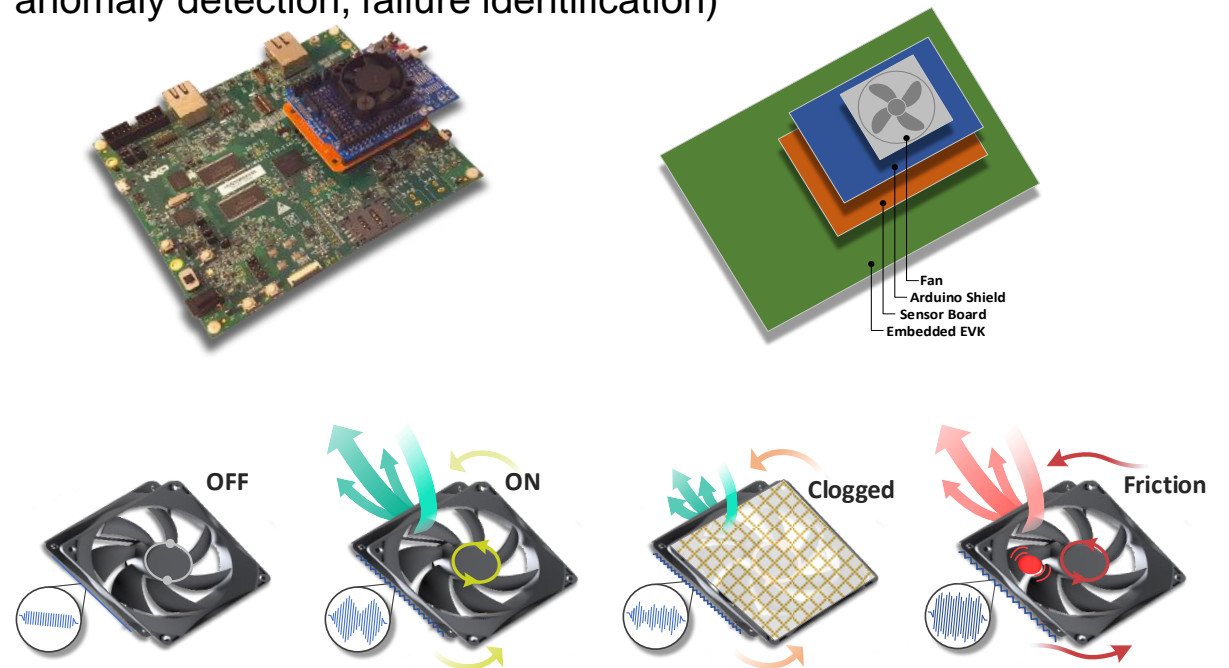

i.MX-RT600 Block Diagram

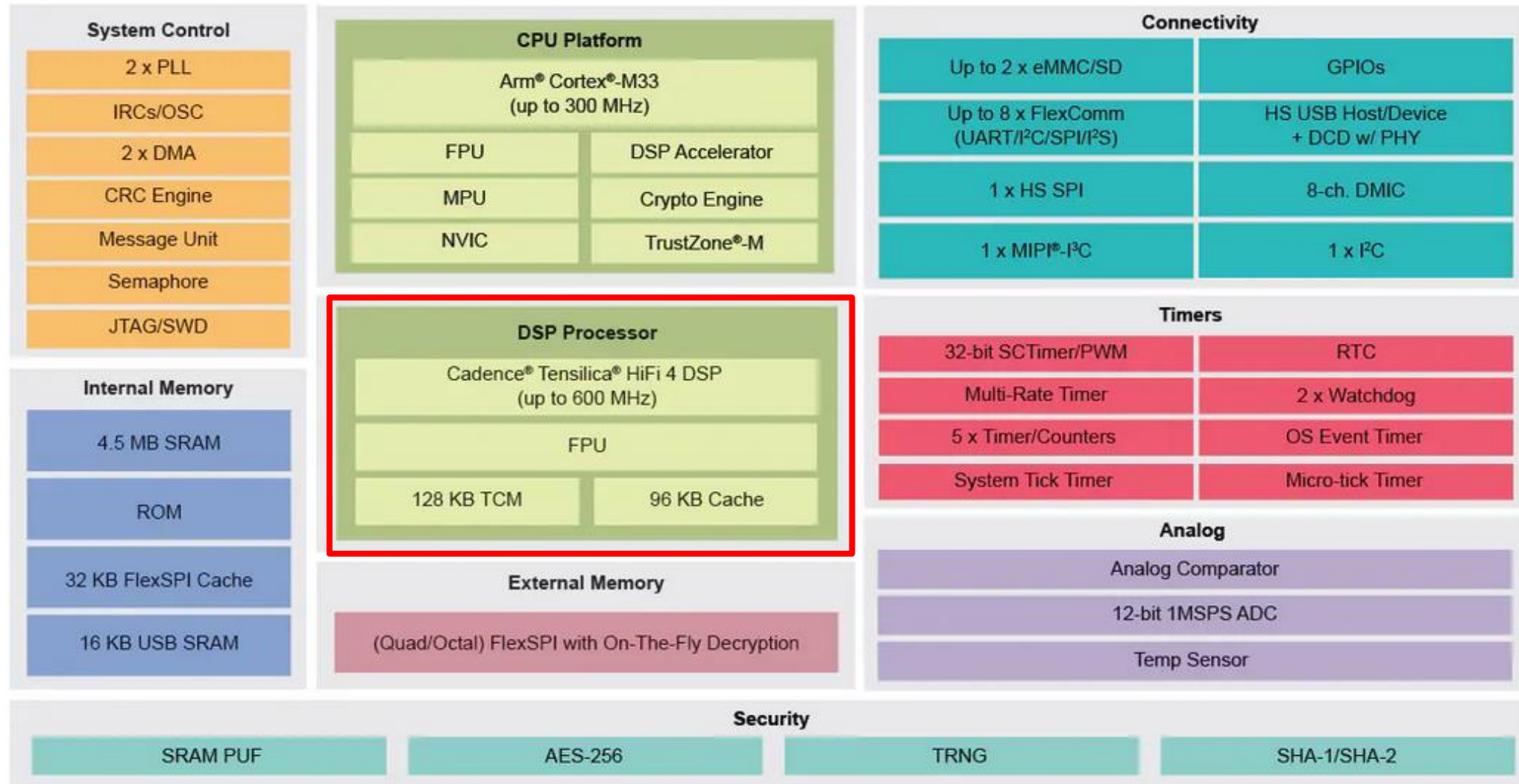

App SW Pack | Person Presence Detection

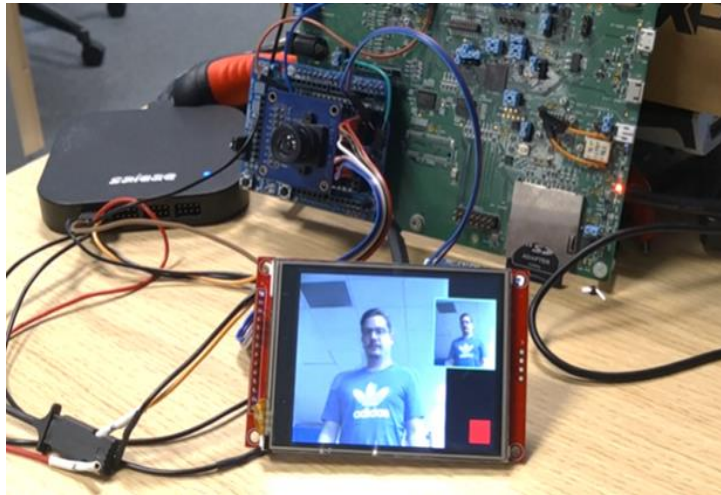
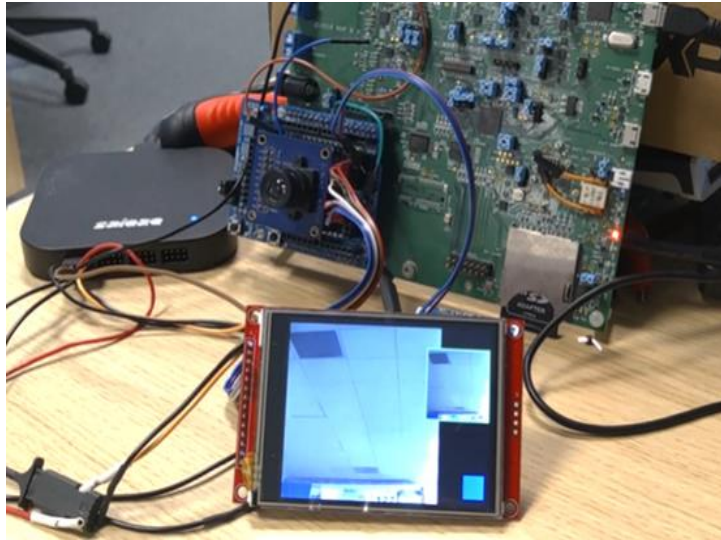

Goal: Detect if a person is standing in front of the camera (visual wake-word)

How: Relies on Deep Learning and uses Visual Wake Words model (based on MobileNet).

- Memory requirements: total of 300KB
- Inference time: 17ms (using Glow for deployment and accelerated on the HiFi4 DSP)



INTREBARI?





SECURE CONNECTIONS
FOR A SMARTER WORLD