

# Internet of Things

Dan Ștefan Tudose

Facultatea de Automatică și Calculatoare  
Universitatea Politehnica București

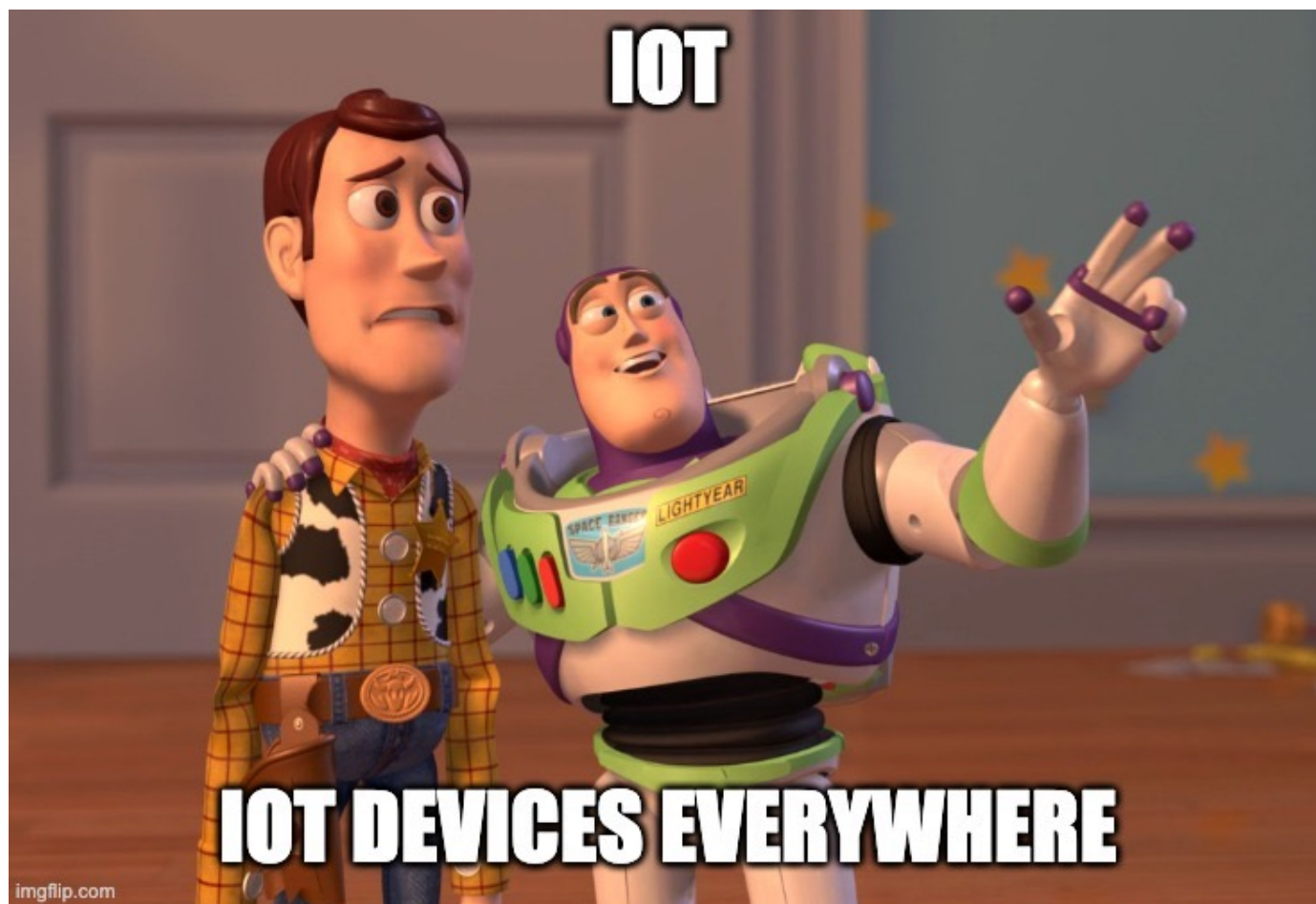

imgflip.com



# About me

Dan Ștefan Tudose

- Associate Professor @ UPB
- Ph.D. in IoT & Wireless Sensor Networks
- Research & teaching:
  - Computer architecture, hardware/software interaction
  - Embedded and Pervasive Computing
  - Wireless Sensor Networks
  - Low Power Computing Architectures, Energy Harvesting
  - Fault tolerance
- Start-ups, Fitbit, Google



# Industrial Revolutions



1<sup>st</sup>  
1760s

Steam engine  
Mechanization



2<sup>nd</sup>  
1870s

Electricity  
Mass production



3<sup>rd</sup>  
1960s

Computers  
Automation  
Internet



4<sup>th</sup>  
NOW

Hyper-  
connectivity

# Moore

Procesare  
Era informației

# More than Moore

Detectie  
Era interacției

# Beyond Moore

Actuare  
Era îmbunătățirii

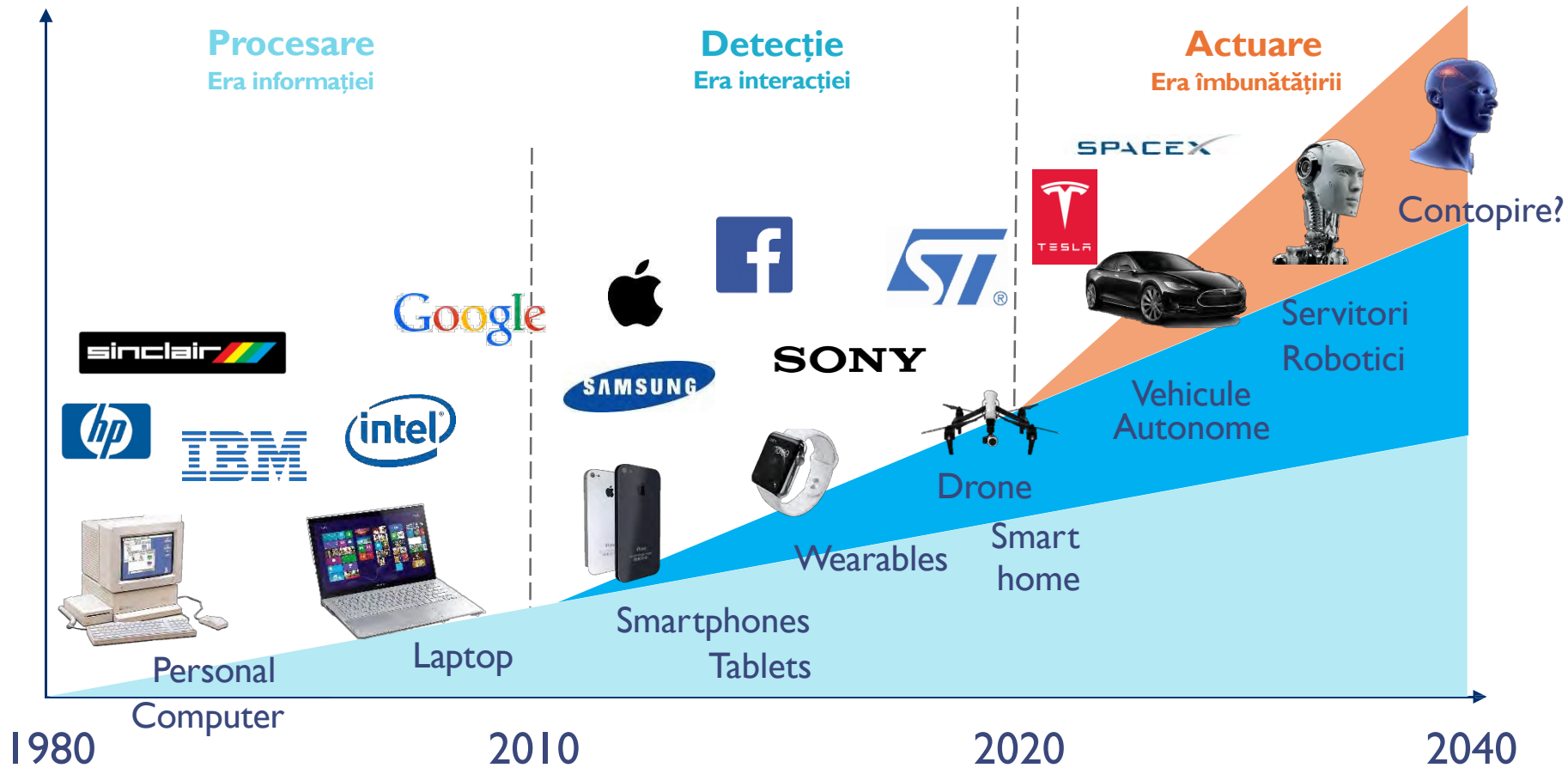

Creștere exponențială

# Emerging Technology Hype Cycle

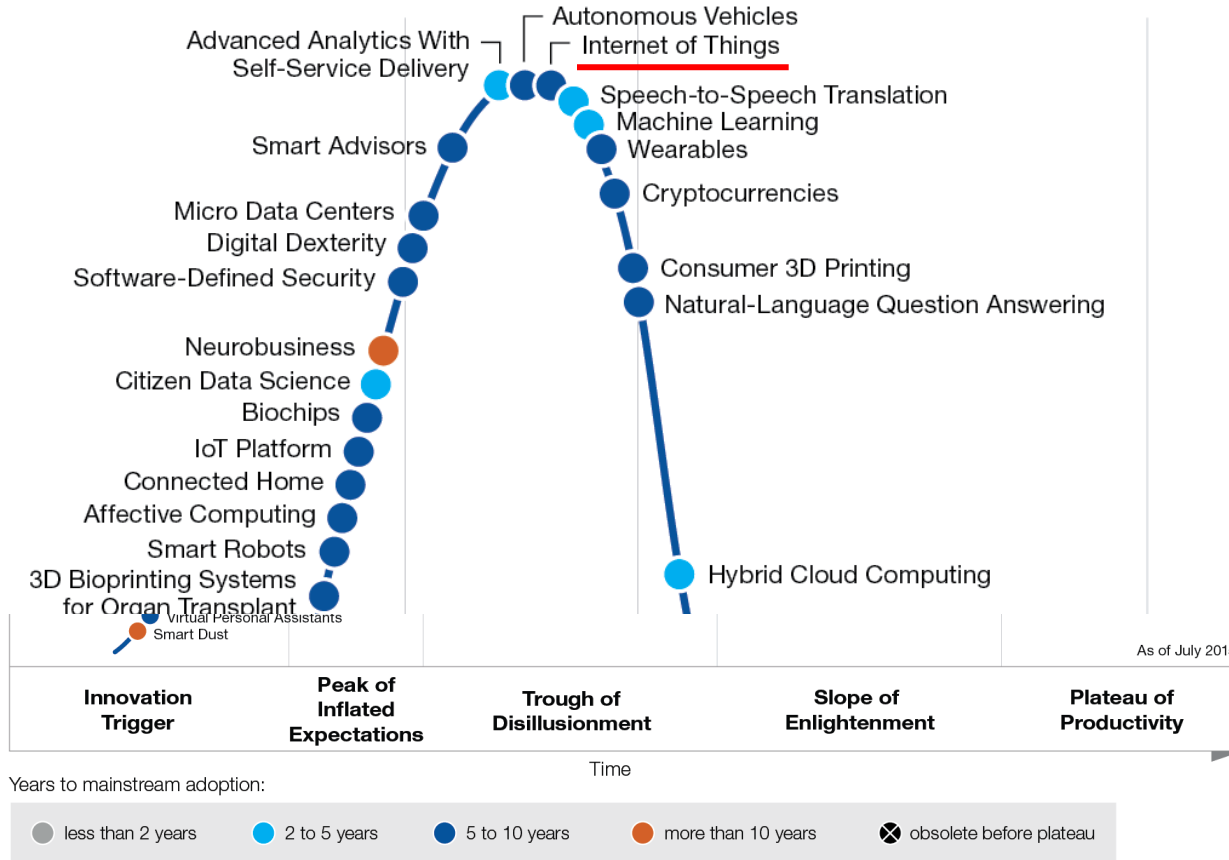

# Characteristics



Small packet size



Low bandwidth (10s-100s kbps)



Star and mesh topology



Low power, battery operated



Low cost



Ad-hoc network, device has limited accessibility



Unreliable wireless medium

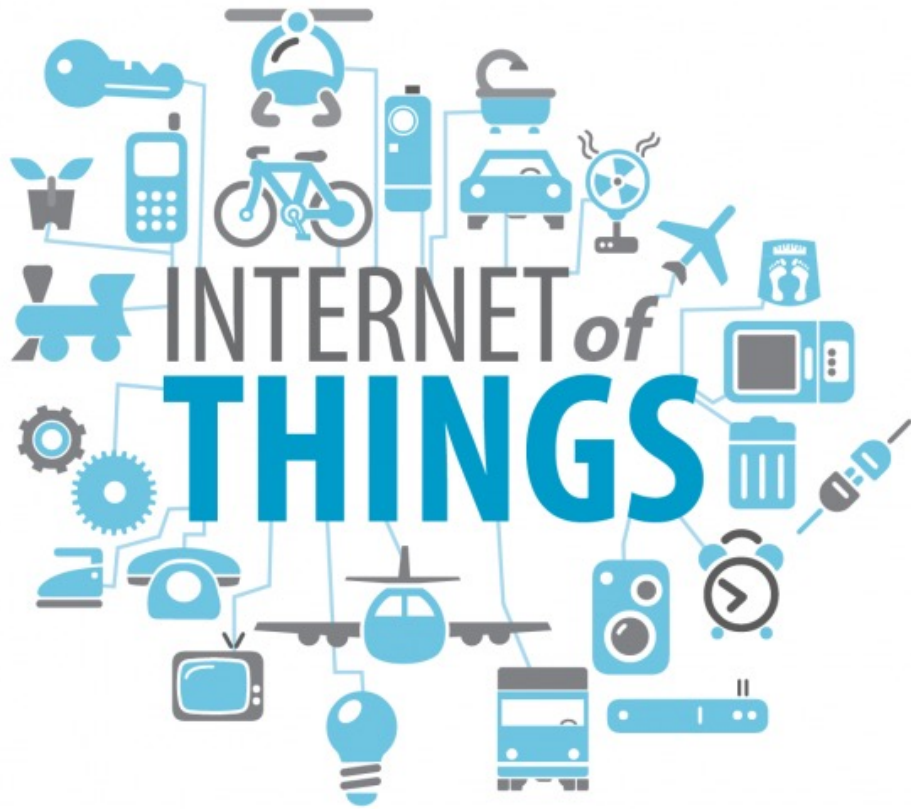

A dynamic global network infrastructure with self-configuring capabilities based on standard and interoperable communication protocols where physical and virtual "things" have identities, physical attributes, and virtual personalities and use intelligent interfaces, and are seamlessly integrated into the information network, often communicate data associated with users and their environments.



# IoT Features

- Dynamic, self-adaptation
- Auto-configuration
- Interoperable communication protocols
- Unique identifier
- Integrated into a larger network

# Architecture

- Multiple sensors (sometimes hundreds or thousands) form a network in order to monitor complex or large physical environments
- The collected information is transmitted wirelessly to a base station (BS), which then propagates it to other devices for storage, analysis and processing.

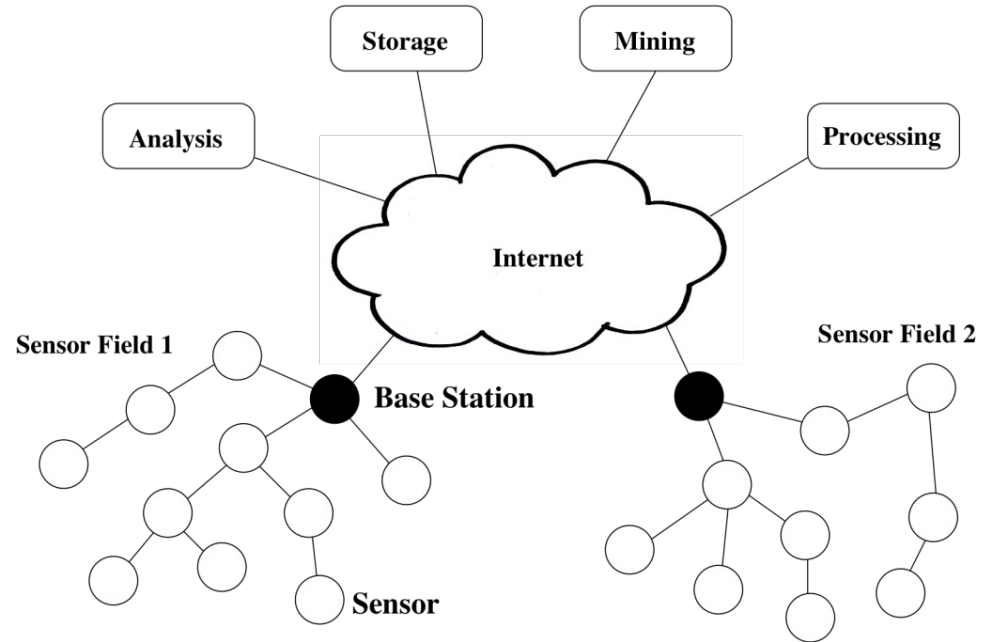

# Single-Hop versus Multi-Hop

- Star topology: Each sensor communicates directly (single-hop) with the base station
  - May require high transmission power and may be unfeasible over a wide area
- Mesh topology
  - It can reduce energy consumption and increase the coverage
  - The routing issue arises

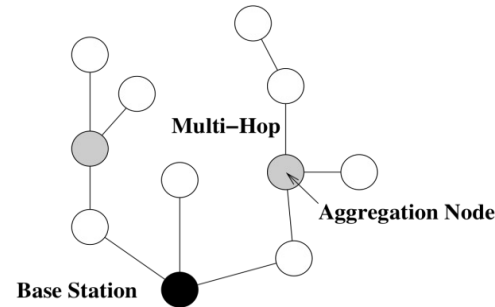
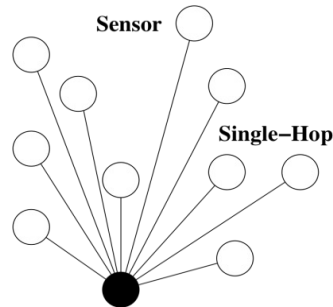

# A Brief History

- DARPA:
  - Distributed Sensor Nets Workshop (1978)
  - Distributed Sensor Networks (DSN) program (early 1980s)
  - Sensor Information Technology (SensIT) program
- UCLA and Rockwell Science Center
  - Wireless Integrated Network Sensors (WINS)
  - Low Power Wireless Integrated Microsensor (LWIM) (1996)
- UC-Berkeley
  - Smart Dust project (1999)
  - Conceptul de “motes”: noduri senzoriale extrem de mici
- Berkeley Wireless Research Center (BWRC)
  - PicoRadio project (2000)
- MIT
  - $\mu$ AMPS (micro-Adaptive Multidomain Power-aware Sensors) (2005)



# What is a Mote?

- **mote** *noun [C] LITERARY*  
something, especially a bit of dust, that is so small it is almost impossible to see  
---Cambridge Advanced Learner's Dictionary  
<http://dictionary.cambridge.org/define.asp?key=52014&dict=CALD>

## UC Berkeley hardware platform evolution

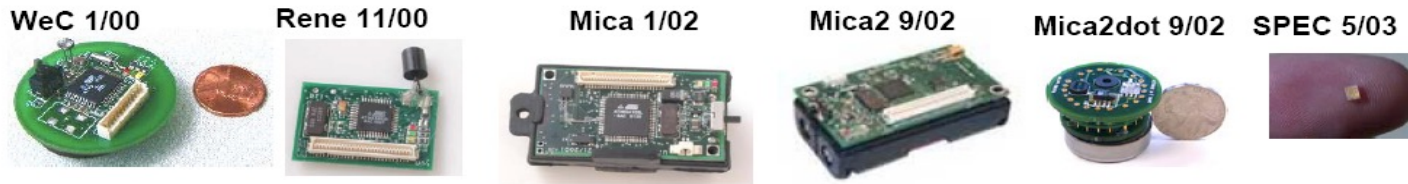

# Node components

- Low-power processor
  - Limited computing power
- Memory
  - Limited capacity
- Radio
  - Low-power
  - Slow data rate
  - Limited range
- Sensors
  - Scalar: temperature, light etc.
  - Image sensors, microphones etc.
- Power supply

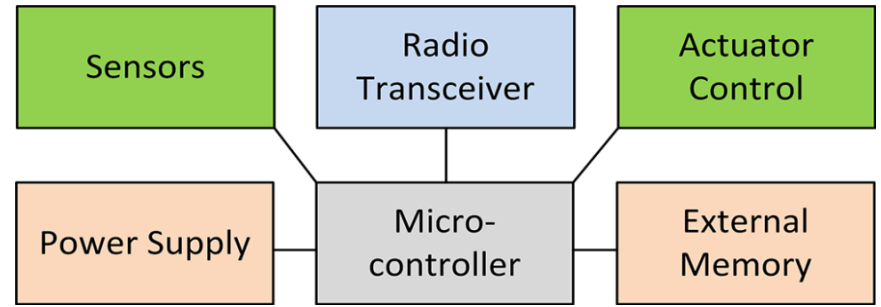

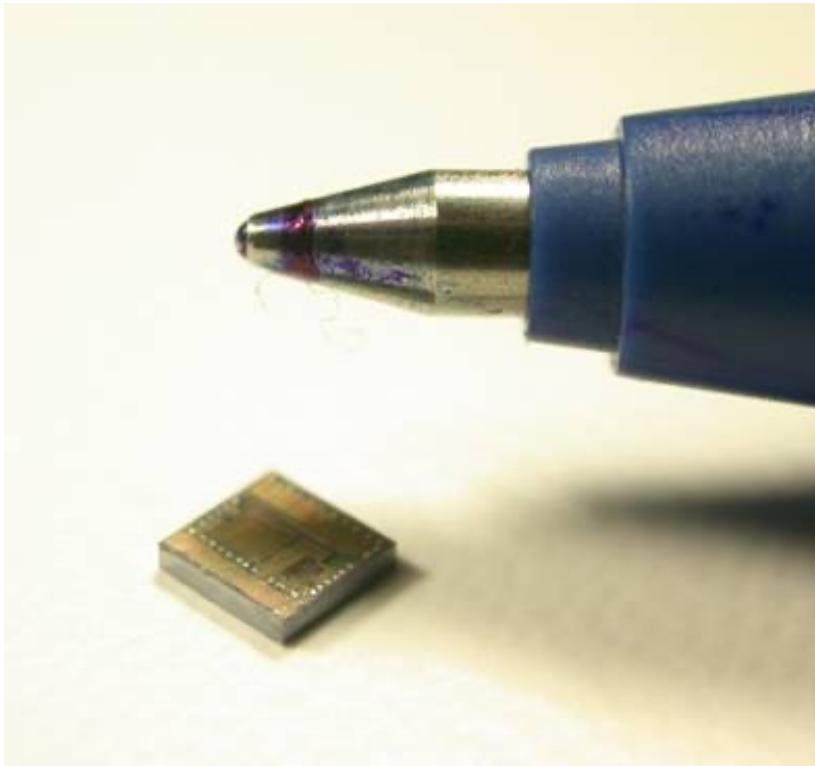

Berkeley Spec (cca. 2000)

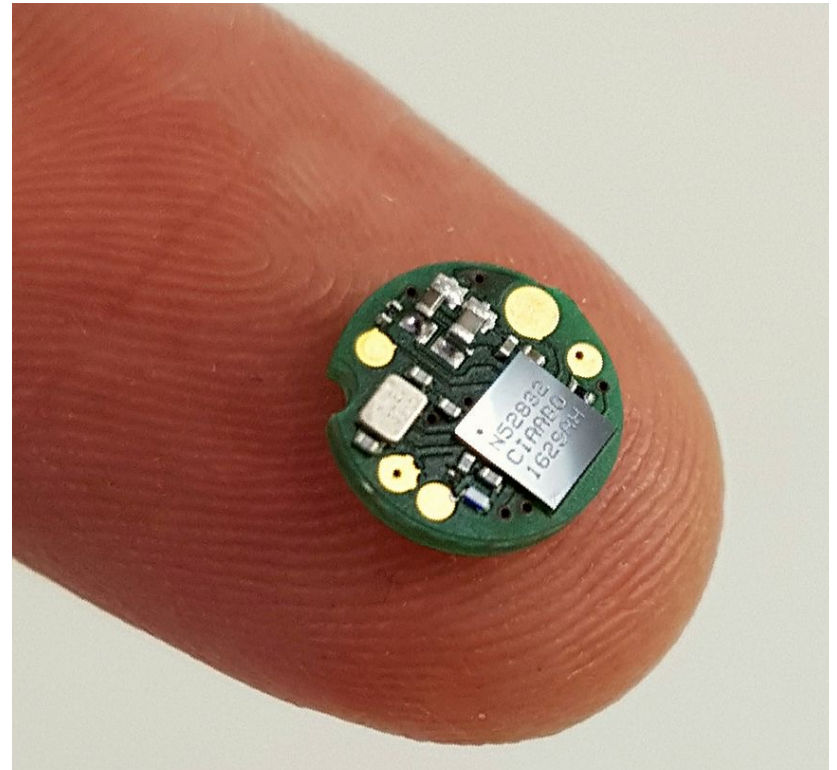

UPB Microsal (cca. 2010)

# ...and many more

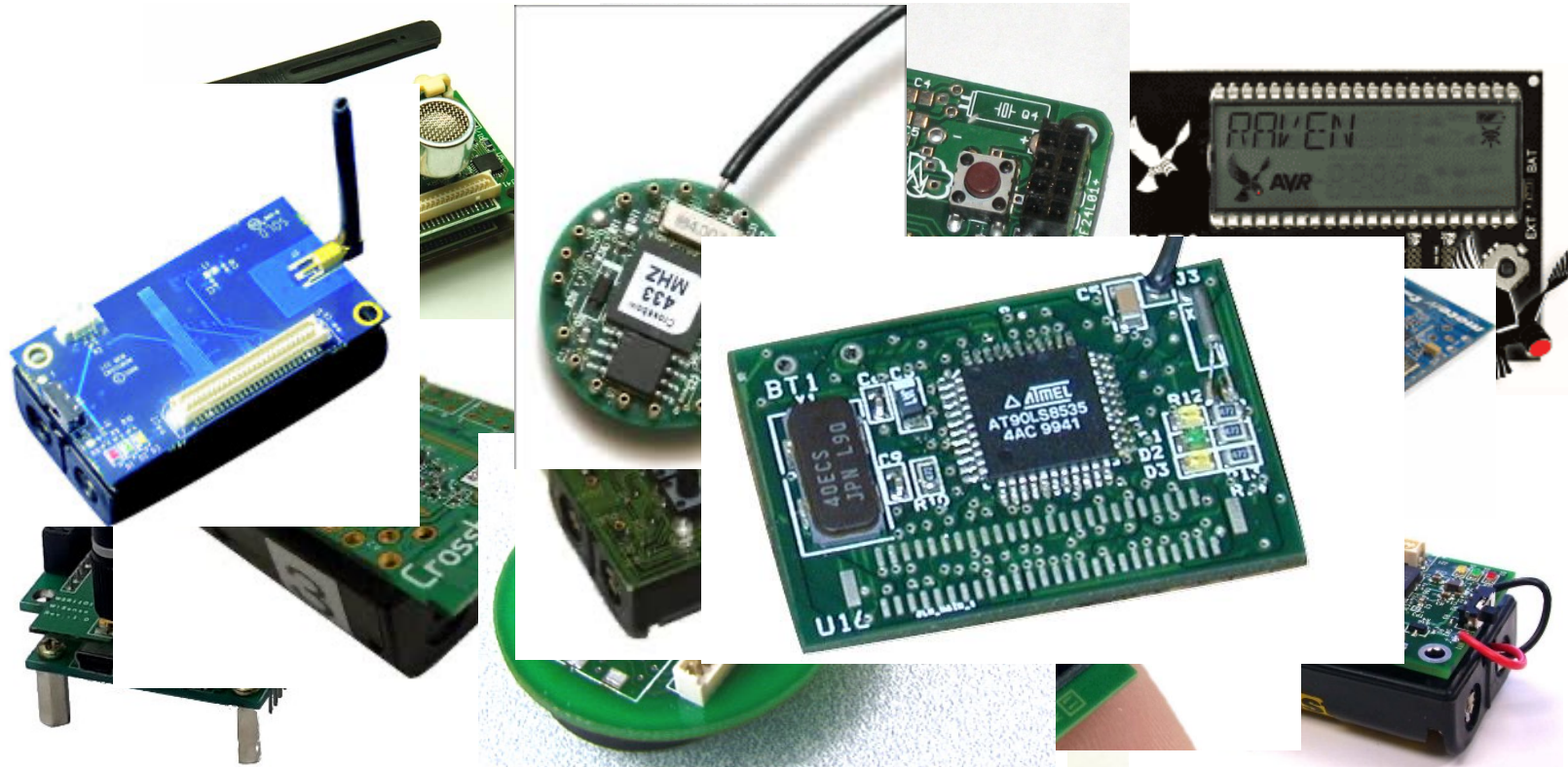



# How did we get here?

- Development of wireless technology
  - MEMS, VLSI
  - Bandwidth explosion
  - Cultural and legislative changes
- Wireless devices are everywhere and people are increasingly receptive to new applications
  - The concept of network (not only data) is a basic one in our society
  - Open source
- Computer Science
  - Network theory, operating systems
  - Cheap and universally available compilers

# Micro-Electro-Mechanical-Systems (MEMS)

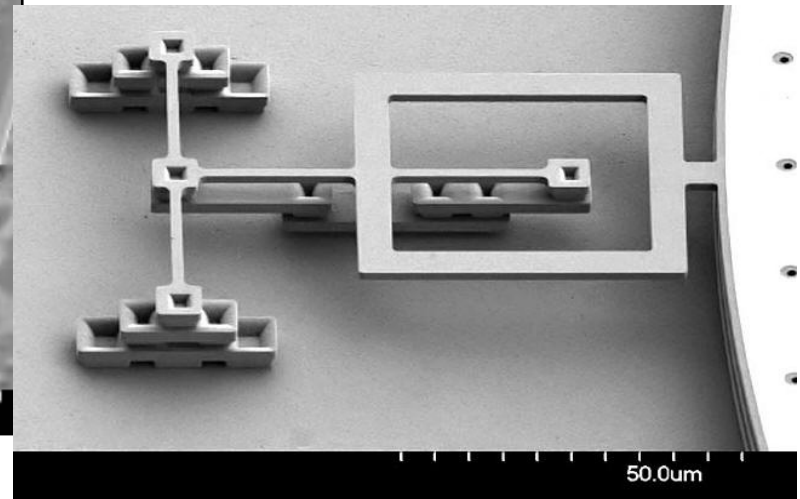
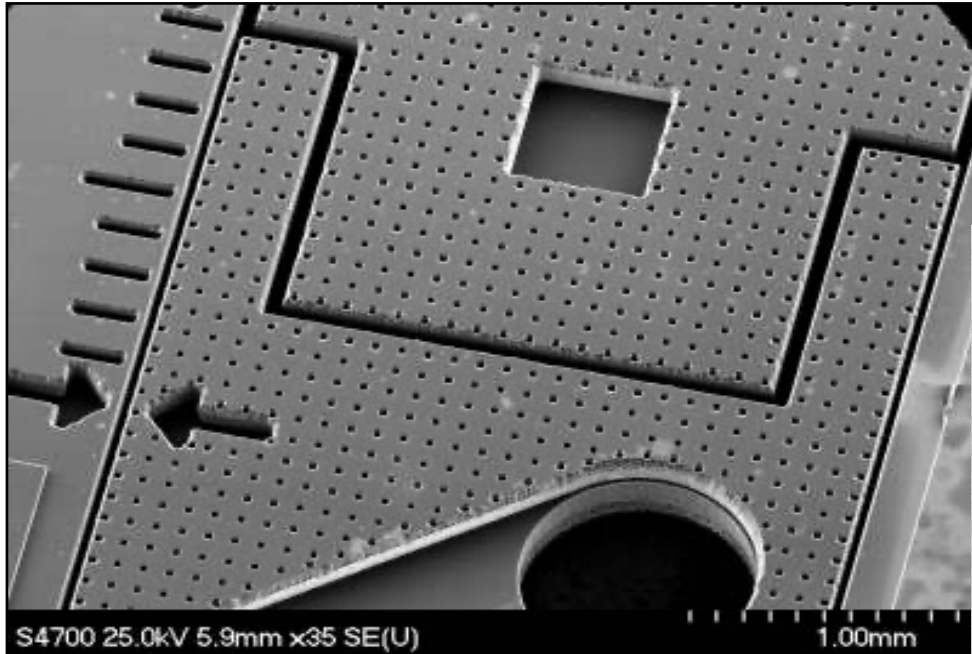

# Micro-Electro-Mechanical-Systems (MEMS)

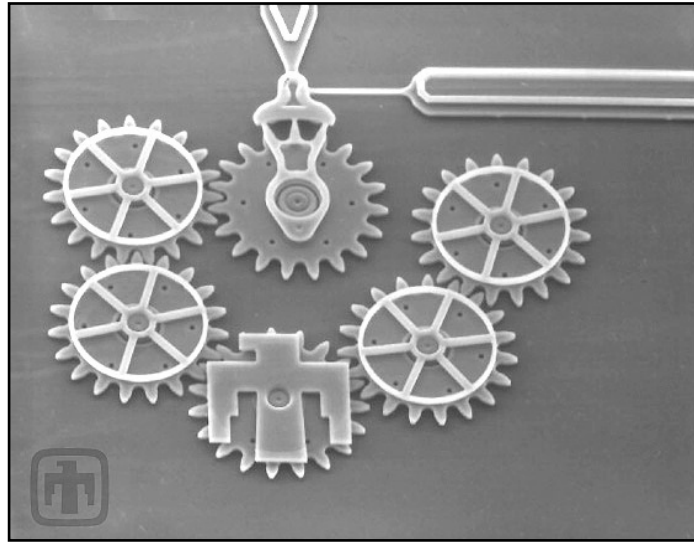

~ 1mm

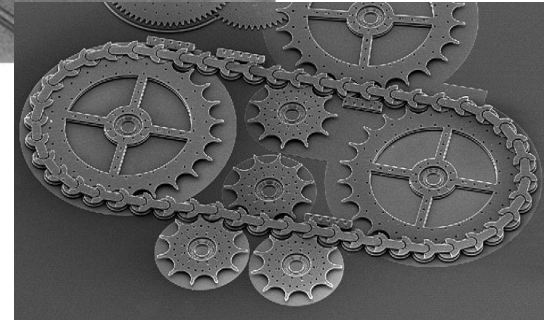
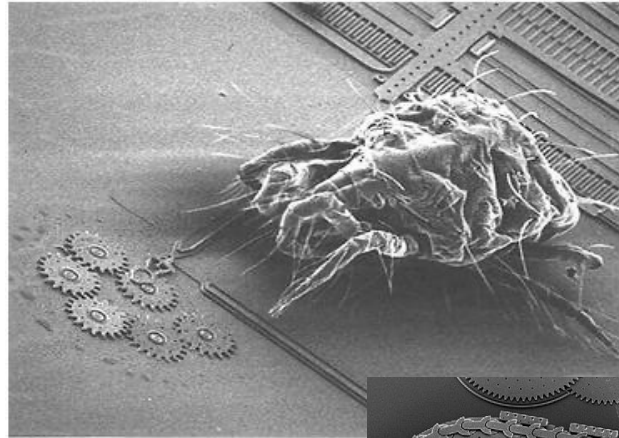

# MEMS sensors

Accelerometers, gyroscopes, magnetometers, microphones, speakers etc.

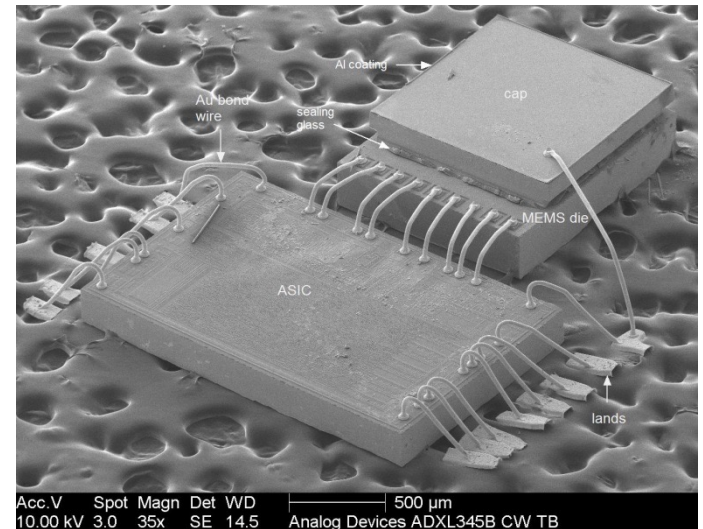
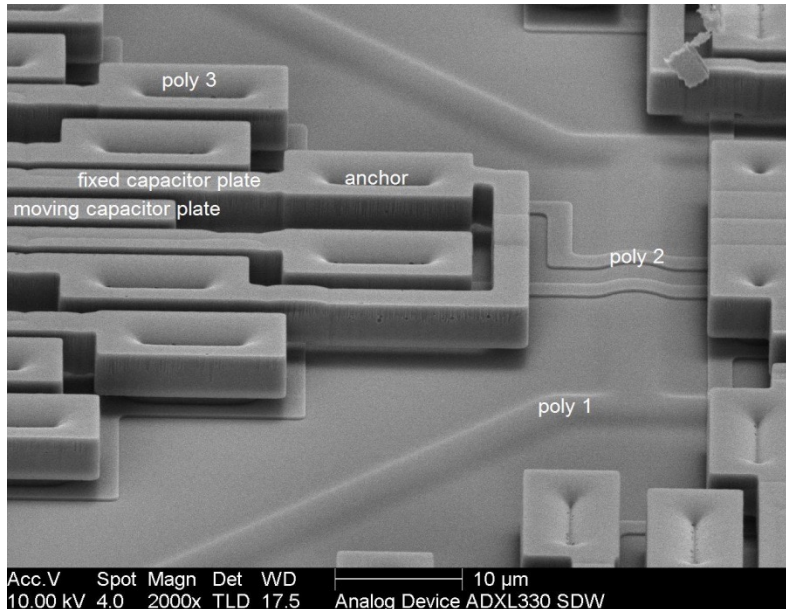

# MEMS for RF

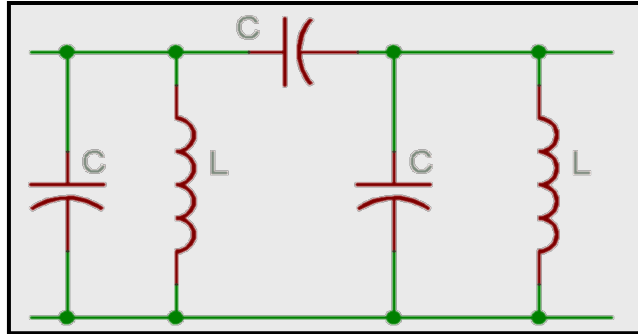

Conventional LC filter –  $Q_s$  aprox. 100-200, takes a lot of space on PCB

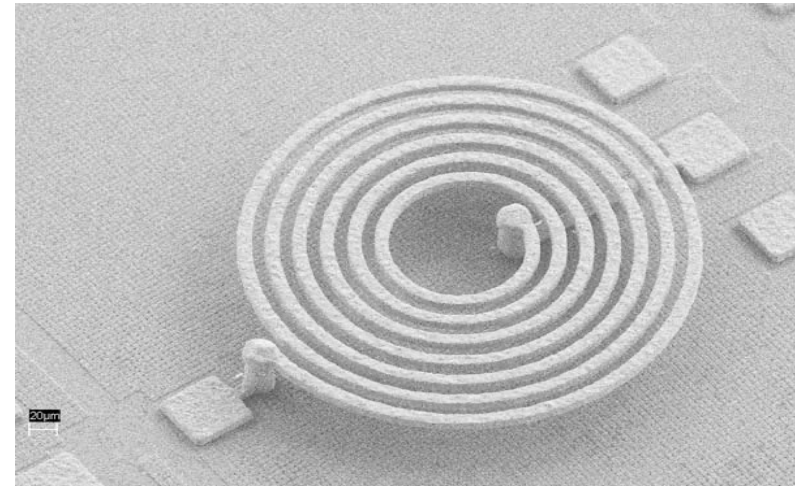
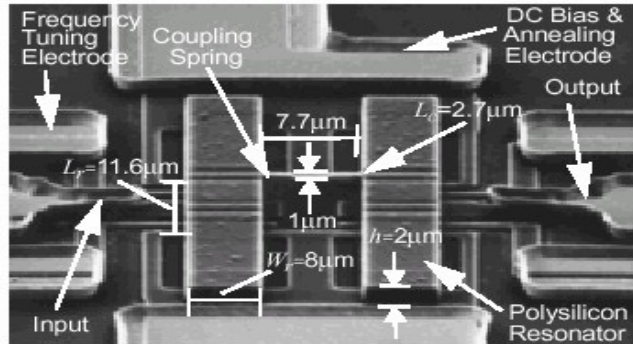

MEMS filter:  $Q_s$  98,000, REALLY small

# IoT Communication

- ❑ Characteristics
  - ❑ low data rate (comparable to a dial-up modem)
  - ❑ strong energy constraints
- ❑ IEEE 802.11 standard
  - ❑ The most common for wireless communication
  - ❑ Can be found on the first IoT networks, or for nodes without big energy constraints
- ❑ IEEE 802.15.4 is a standard for short-range communication, specially designed for WSN networks
  - ❑ low data rate
  - ❑ low power consumption
  - ❑ widespread use in academic IoT or commercial solutions

# Some Technical Aspects

- ❑ Networking is a key component (different levels)
- ❑ Addressing schemes (IPv4 vs. IPv6)
- ❑ Data transmission (ZigBee, WiFi, 5G, LTE etc.)
- ❑ Transfer rate (Kbps, Mbps, Gbps)
- ❑ Medium control (MAC layer and Data Link Layer)
- ❑ Cross-geography (CoAP, MQTT etc.)



# Example: Sparrow

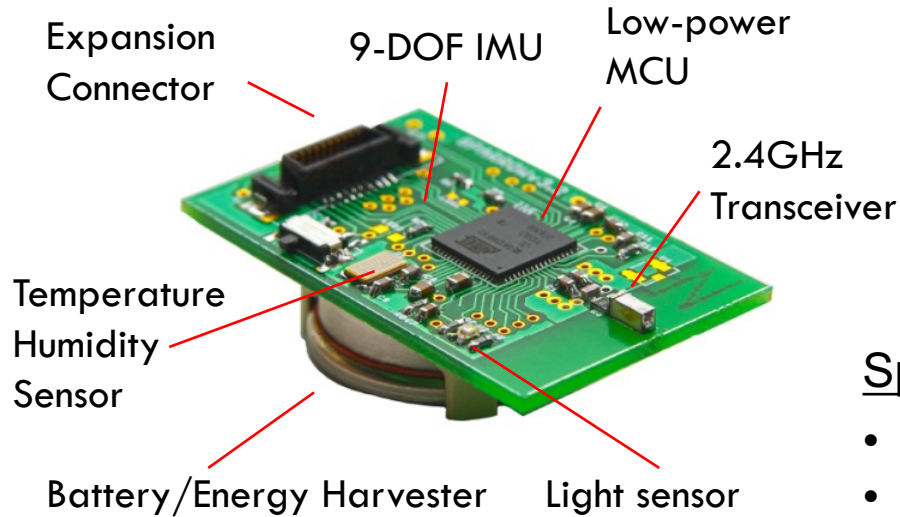

Works with IEEE 802.15.4

256kbps transfer speed



## Specs:

- 16MHz
- 8KB RAM
- 128KB Flash
- ~ \$10
- 50mW, 36uW (sleep)
- 7g, 50x30x5mm
- 4.77MHz
- 16-256KB RAM
- 160KB Floppies
- ~ \$6,000
- ~ 64W
- 12kg, 500x140x400mm



# WSN @ UPB

- Sparrow - Wireless Sensor Network creată special pentru studiul energy harvesting
- Ultra Low-power
- Poate rula o multitudine de sisteme de operare și stive de protocol
- Arduino compatible!
- Autonomie măsurată în ani de zile sau infinită

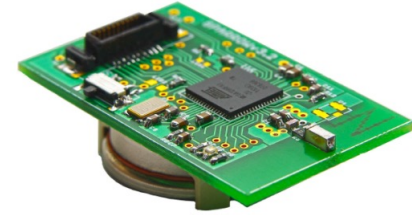
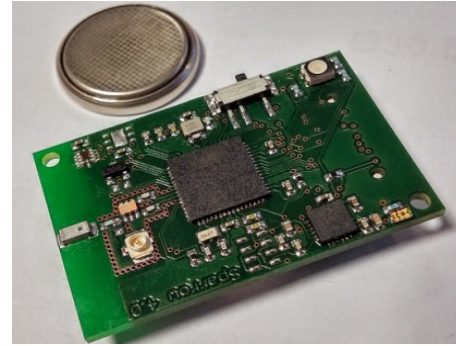

# Technical specs

	Range
Humidity	Meas. interval: 0 ... 100 % Meas. error: $\pm 2\%$ RH
Luminosity	Meas. interval: 0...100000lux Visible & IR UV index
Temperature	Meas. Interval: $-40 \dots 100^{\circ}\text{C}$ Meas. error: $\pm 0.5^{\circ}\text{C}$

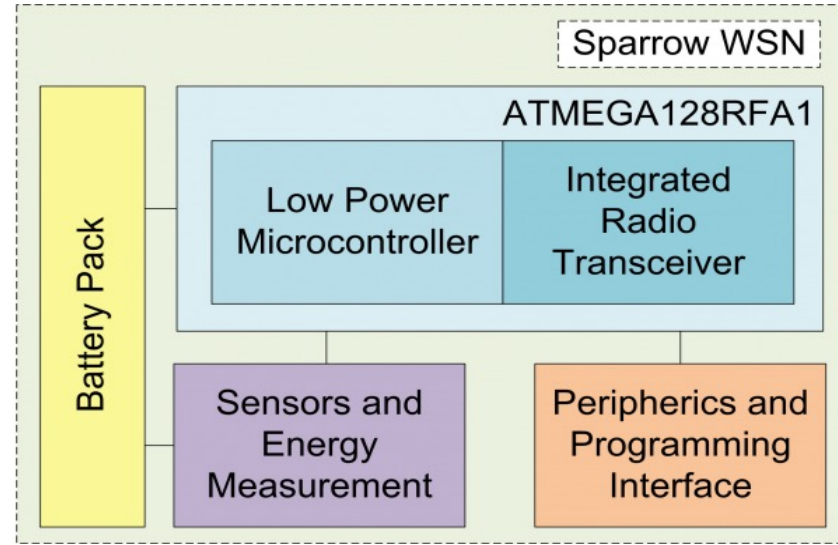
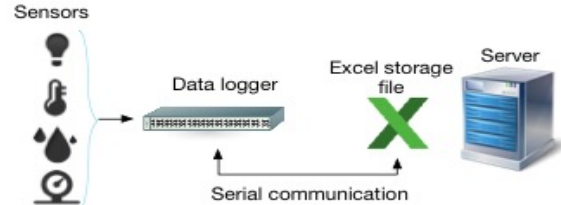

# Deployment: Off-grid building

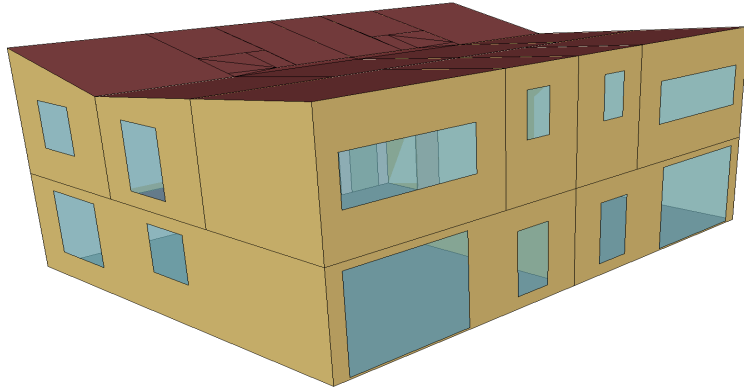

# Floor plan

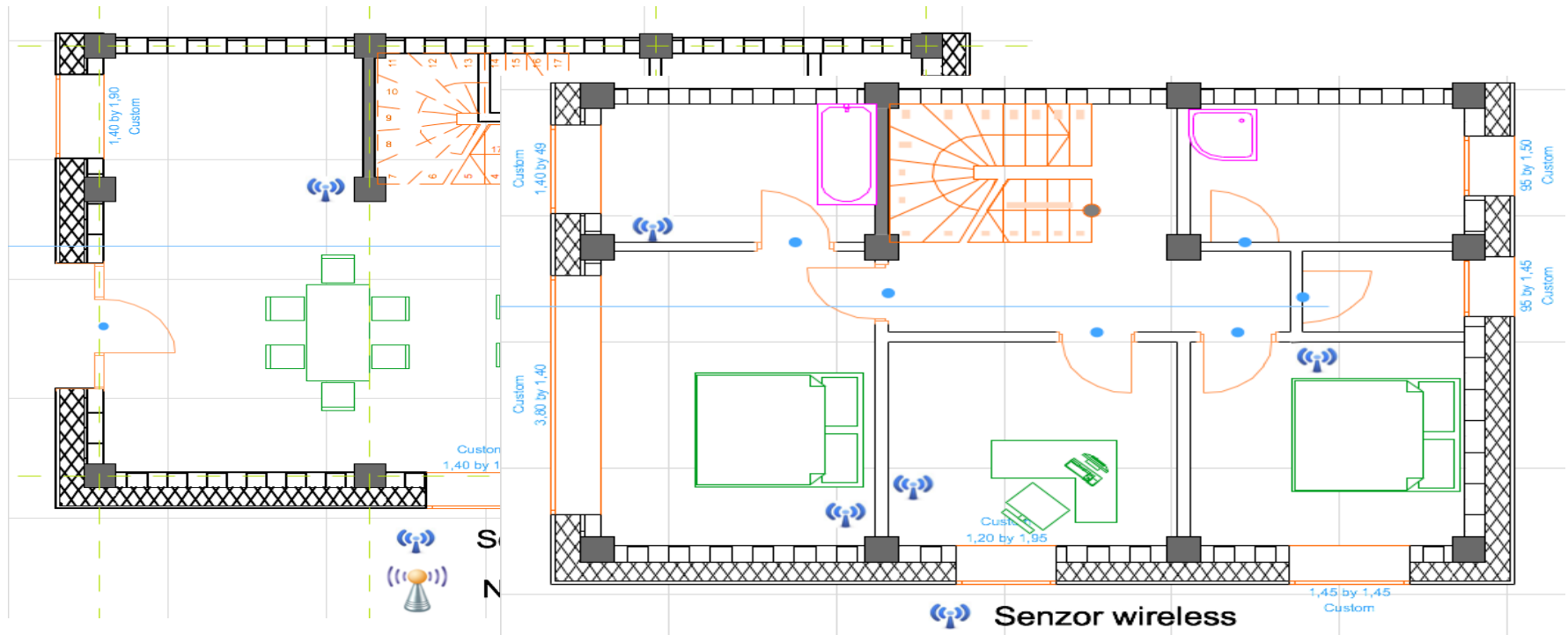

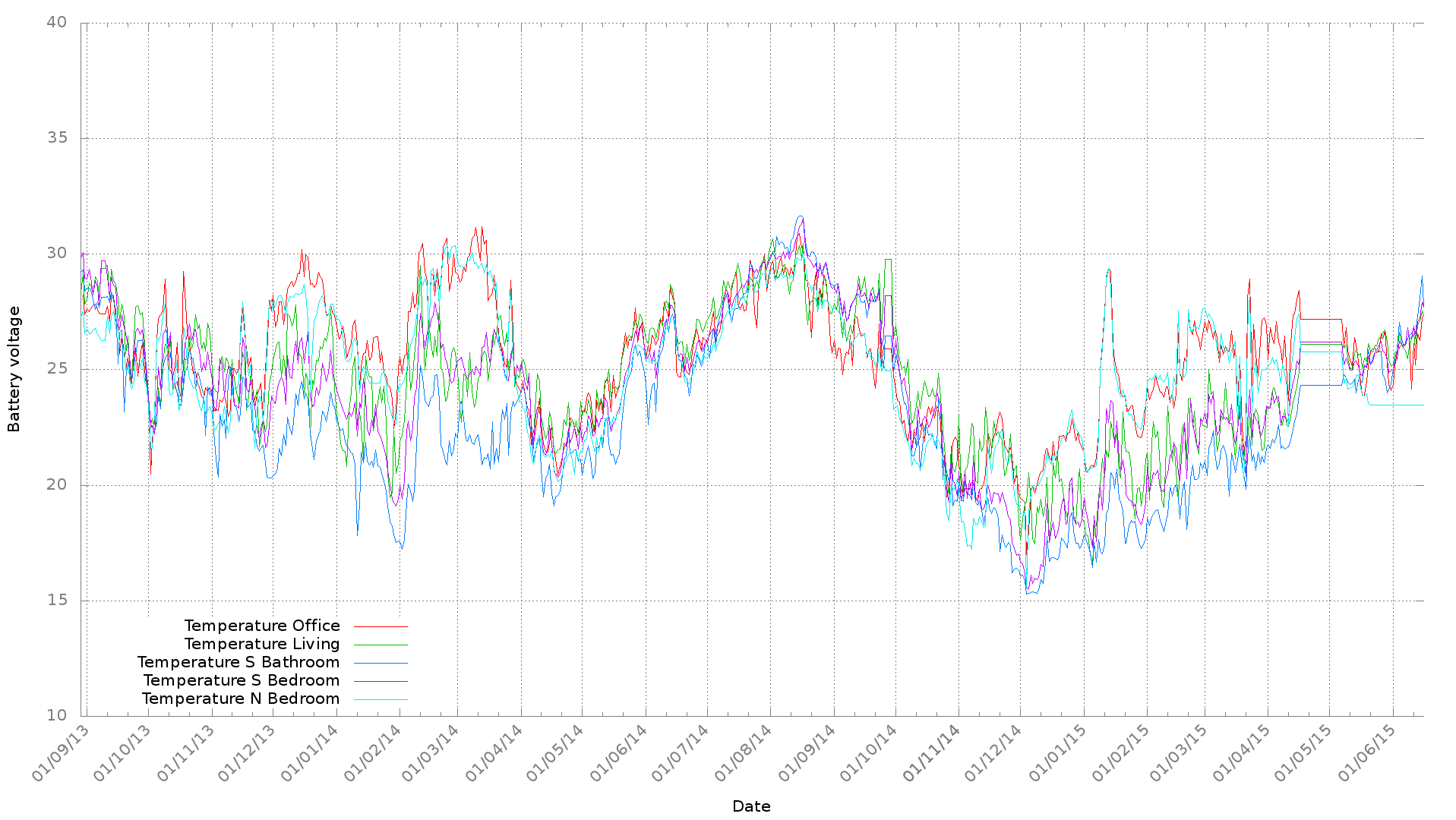

# Energy-Independent Indoor WSN

Employs energy harvesting

- Miniature Solar Panel
- Ultra low-power DC/DC
- Super-capacitor storage
- Dynamic duty-cycling using energy estimation algorithms
- Achieves total energy independence in outdoor & indoor scenarios

20F Supercap

PV panel  
with DC/DC  
converter

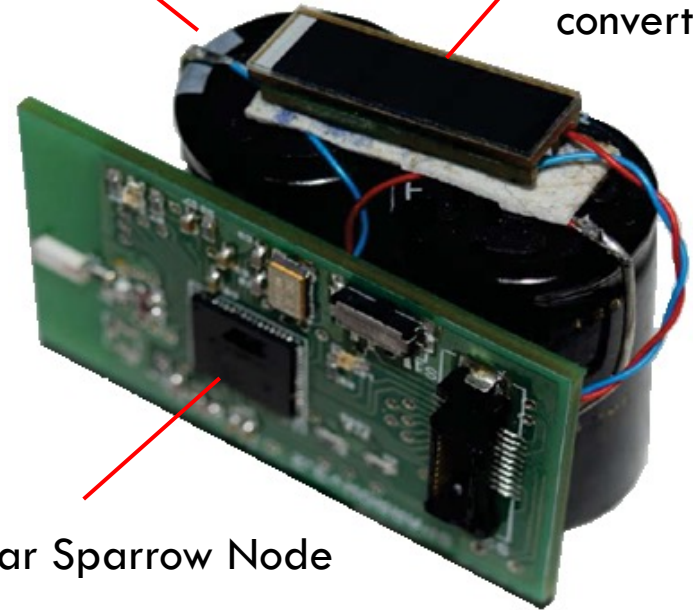

Regular Sparrow Node

# Results

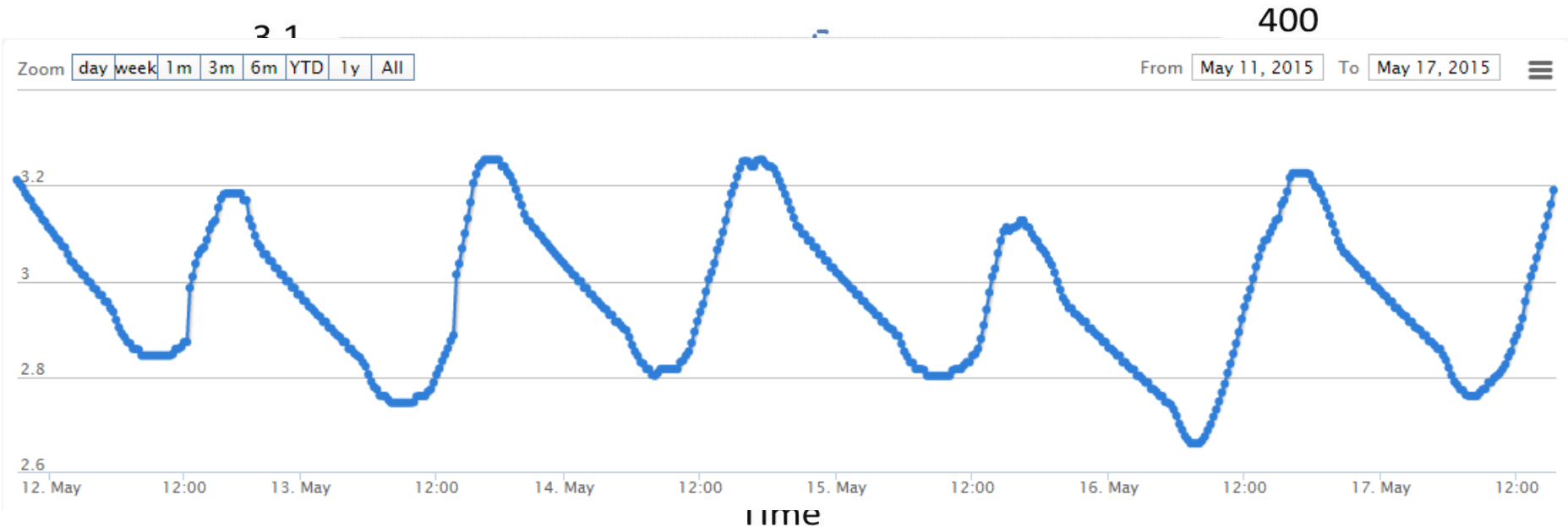

— Setup B, voltage    - - - Setup B, sleep



# Seismic Building Monitoring

- The interaction between seismic waves and building structures are not well defined or easy to model
- Existing seismic monitoring networks can't detect structural deformation in buildings

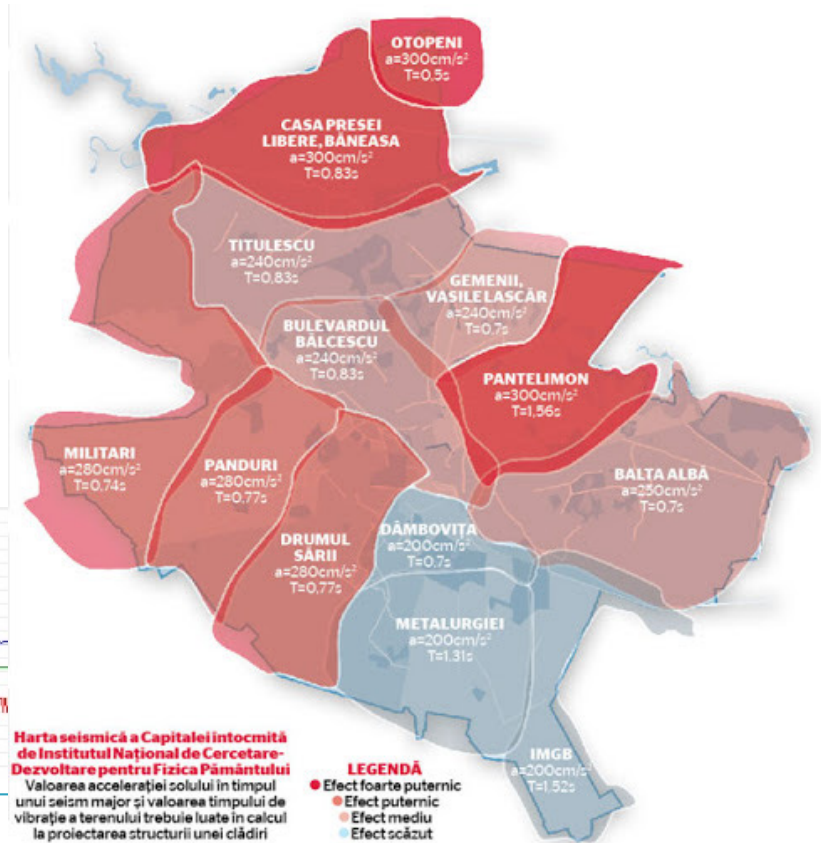
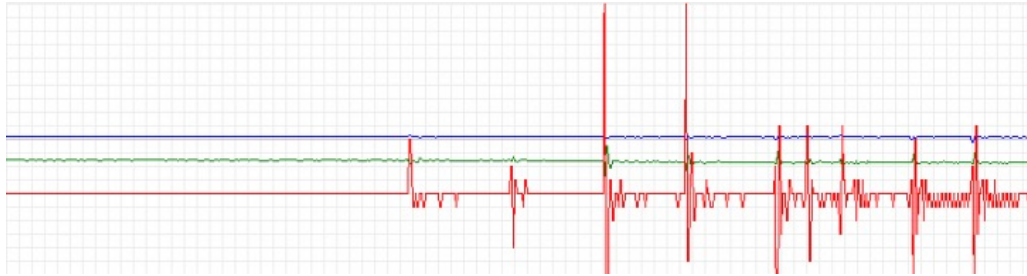



# Measurement nodes

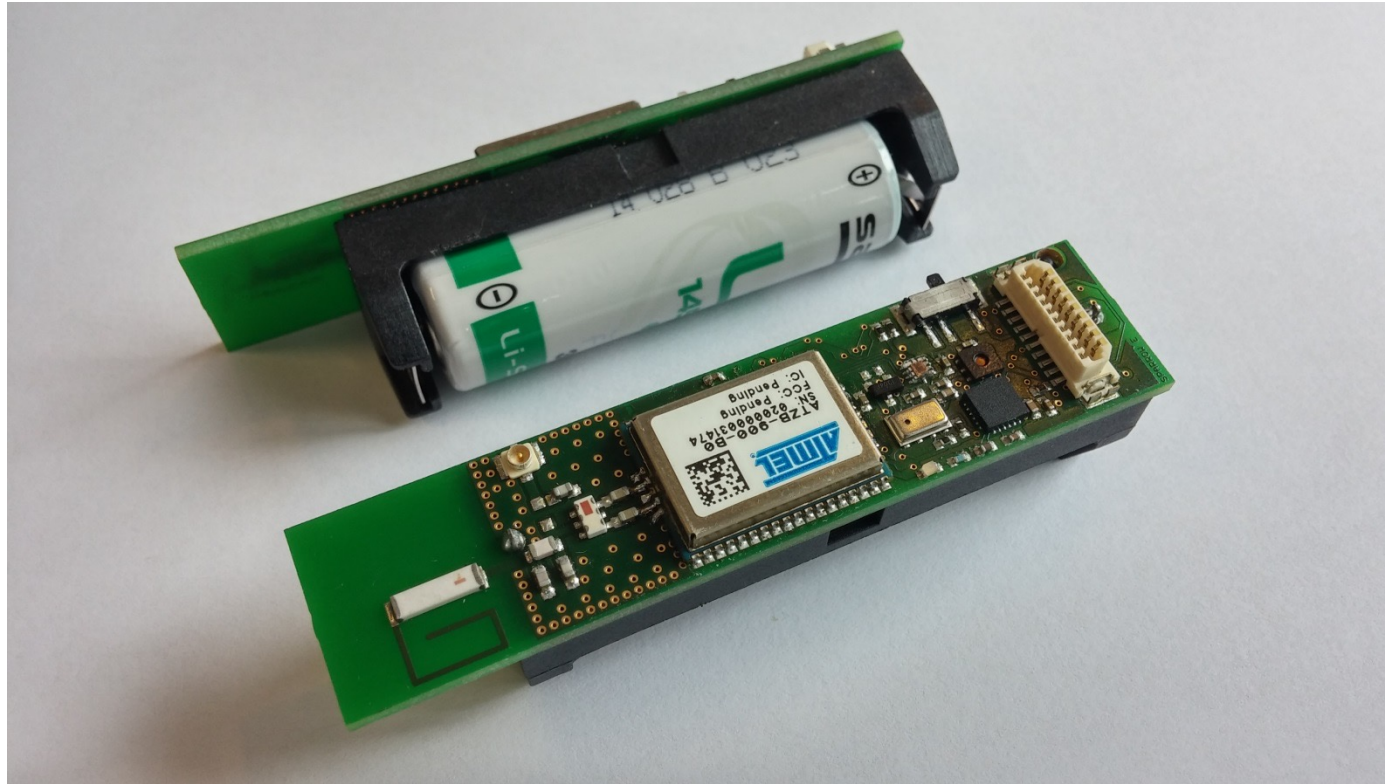

# Results

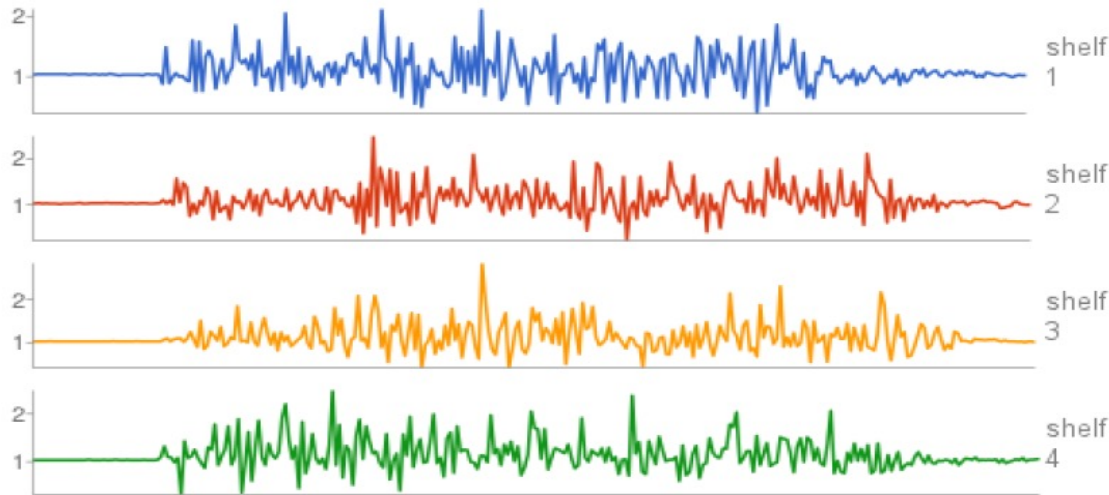

# Microsal – Salivary Pacemaker

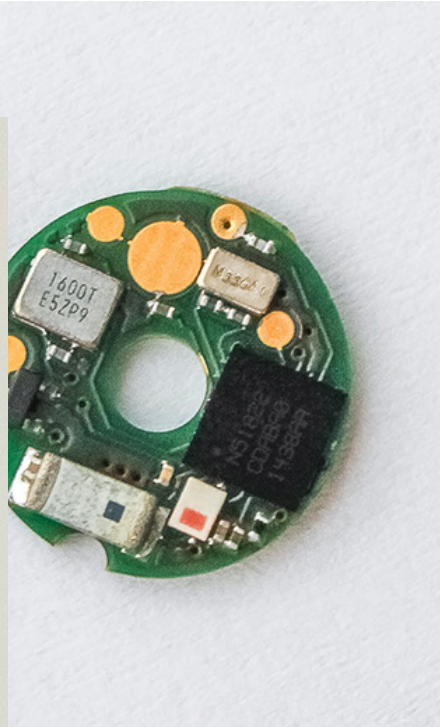
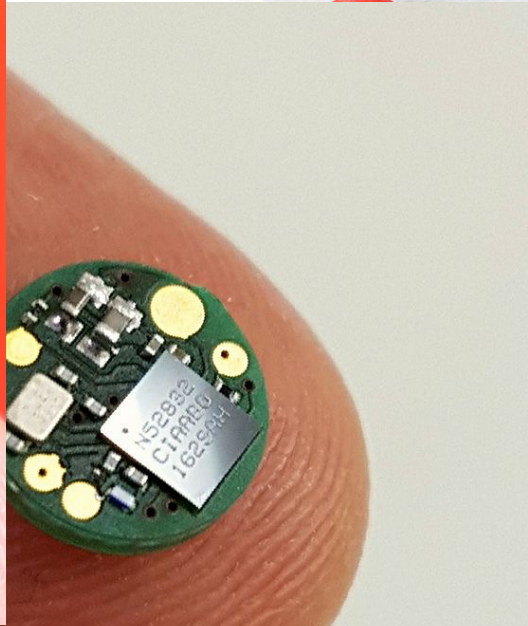

# TinySense

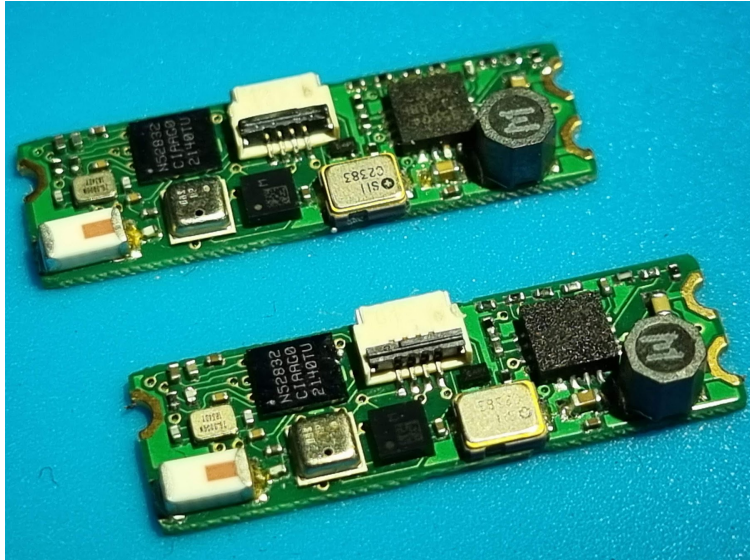

# Thank you!

