

Elemente de Informatică Mobilă

Dragoș Niculescu (dragos.niculescu » cs pub ro)

These lecture slides are based in part on materials from dr. Schiller's slides online at Freie Universitat Berlin
<http://www.mi.fu-berlin.de/inf/groups/ag-tech/teaching/index.html>

- **Structura cursului – 2 ore/săpt.**
 - Teorie: nivel fizic, MAC, TCP, localizare
 - Tehnologie: 3G, 4G, WiFi, VoiP, GPS
- **Structura laboratorului – 2 ore/ săpt.**
 - Practică: Android, rețelistică în Android
- **Structura notei**
 - 20% extemporale, fără materiale
 - 50% colocvii – **nota minimă 5.0**
 - 35% examen scris/oral, cu materiale – **nota minimă 5.0**
- **Echipa: Dragoș Niculescu, Andrei Roșu-Cojocaru, Radu Stoenescu**

- planșe de prezentare
 - NU** sunt suficiente pentru examen
- documentație obligatorie:
 - Jochen Schiller, *Mobile Communications 2nd ed*, capitole 3,4,8,9
 - Matthew Gast, *802.11 Wireless Networks: The Definitive Guide* capitole 2,3,4,7
 - A. Tanenbaum 4th ed, *Rețele de calculatoare*, selecție
 - H. Sinnreich *Internet Communications using SIP*, cap 6,18
 - Alte documentații postate
 - actualizat <http://ocw.cs.pub.ro/courses/eim/reading>

- Informatica mobilă cuprinde

- Sisteme distribuite
- Rețelistica mobilă/radio
- Hardware/Software mobil
- Ubiquitous computing
- Pervasive computing
- Sensor networking
- ...

- Problematika

- Interfața
- Consum energie
- Securitate
- Conectivitate
- Scalabilitate
- Localizare

Cum se plasează acest curs în problematica generală a informaticii mobile?

Probleme interconectate!

Discuție paranteză 1



Discuție paranteză 2



mobile computing?



- **Informatica mobilă cuprinde**
 - Sisteme distribuite
 - Rețelistica mobilă/radio
 - Hardware/Software mobil
 - Ubiquitous computing
 - Pervasive computing
 - Sensor networking
 - ...

- **Problematica**
 - Interfață
 - Consum energie
 - Securitate
 - Conectivitate
 - Scalabilitate
 - Localizare

- **Consum de energie**
 - Ecran
 - Rețea
 - CPU: consum de putere $\sim NCV^2f$
 - N: număr de tranzistoare
 - C: capacitate internă, în scădere
 - V: voltaj
 - f: frecvența de ceas
- **Resurse limitate**
 - Stocare, CPU -> cloud?
 - conectivitate
- **Pierderea datelor**
 - Probabilitate mare -> design (backup, privacy)
- **UI limitat**
 - compromis dimensiune - portabilitate

Energia consumată: 3G LTE, WiFi, BT



Măsuratori Android, cu ecranul închis

ping -c1 8.8.8.8(3G, RDS)
wget/iperf

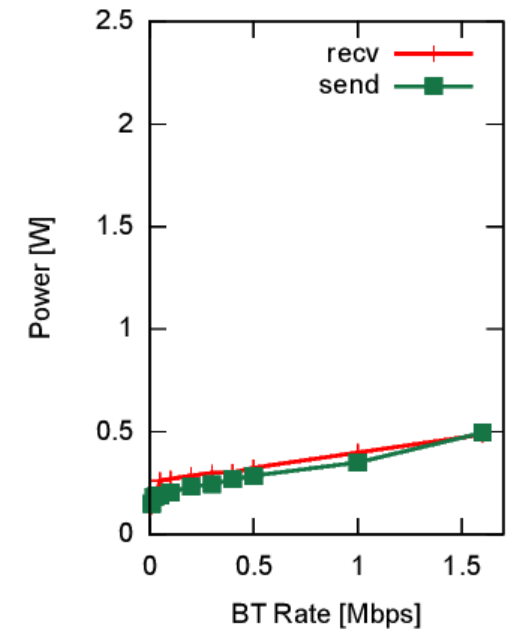
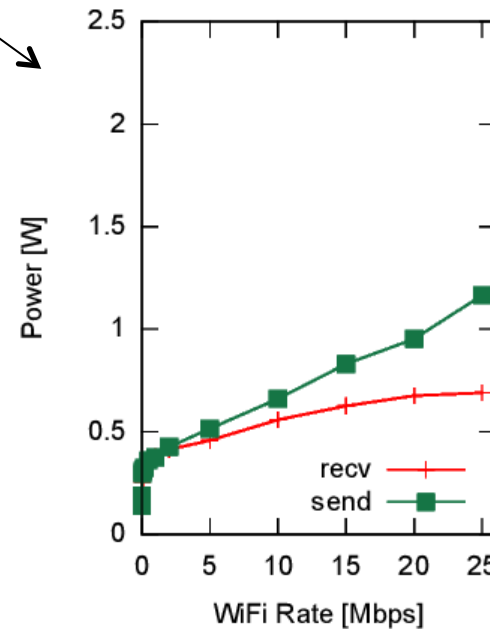
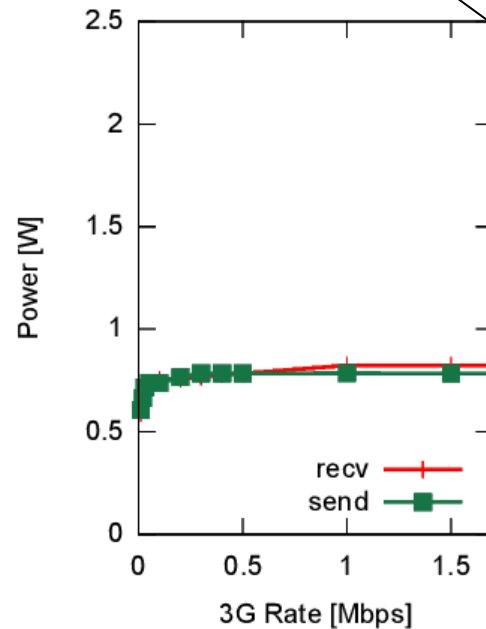
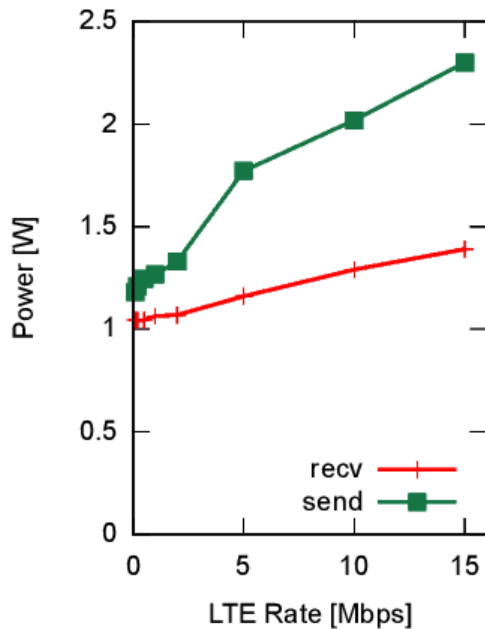
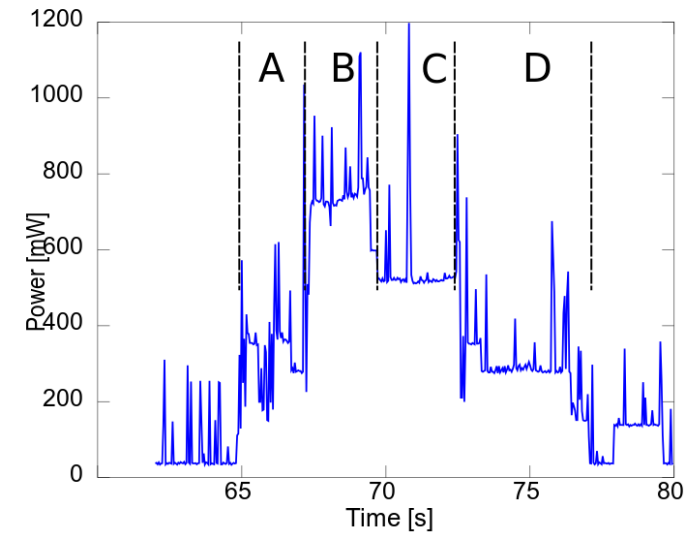

C. Nicuțar et al, Using Cooperation for Low Power Low Latency Cellular Connectivity. CoNEXT 2014

Energia consumată de aplicații/3G



Applications	Network 1 T1=6s, T2=6s		
	Average current (mA)	Projected battery life (h)	Drain speed
None	6.1	268.7	x1
Google services	9.0	183.7	x1.5
Google, WhatsApp	12.3	134.4	x2.0
Google, Viber	12.6	131.4	x2.0
Google, Skype	17.2	95.9	x2.8
Google, Facebook	10.2	162.6	x1.7
Google, Skype, WhatsApp, Viber	22.4	73.5	x3.6
Applications	Network 2 T1=8s, T2=12s		
	Average current (mA)	Projected battery life (h)	Drain speed
None	5.9	279.7	x1
Google services	22.5	73.3	x3.8
Google, WhatsApp	28.3	58.4	x4.8
Google, Viber	27.5	59.9	x4.7
Google, Skype	31.8	51.9	x5.4
Google, Facebook	22.9	72.1	x3.9
Google, Skype, WhatsApp, Viber	54.5	30.3	x9.2

Table from A. Aucinas et al, Staying Online While Mobile: The Hidden Costs, CONEXT 2013

mobile computing?



- **Informatica mobilă cuprinde**

- Sisteme distribuite
- Rețelistica mobilă/radio
- Hardware/Software mobil
- Ubiquitous computing
- Pervasive computing
- Sensor networking
- ...

- **Problematica**

- Interfața
- Consum energie
- ~~Securitate~~
- **Conectivitate**
- Scalabilitate
- Localizare

Probleme interconectate!

Discuție paranteză 2



wireless vs. wired



- **Pierderi mari**
 - Distanță, interferență
- **Legislație**
 - Frecvențe cu și fără licență
- **Rate de transmisie reduse**
 - Bluetooth ~2Mbps, WiFi ~ 50Mbps, 3G ~8Mbps, GSM~ 150 kbps, LTE ~ 20 Mbps; distanțe
- **Latență și jitter crescute**
 - Conectarea în 2G/3G ~ secunde, LTE,WiFi ~ milisecunde
- **Mediul mereu partajat**
 - MAC, capacitate, coliziuni, securitate
- **Securitate redusă**
 - Mediu cu difuzare (broadcast)

- Informatica mobilă cuprinde
 - Sisteme distribuite
 - **Rețelistica mobilă/radio**
 - Hardware/Software mobil
 - Ubiquitous computing
 - Pervasive computing
 - Sensor networking
 - ...



Cum se plasează acest curs în problematica generală a informaticii mobile?

- Problematica

- Interfața
- Consum energie
- Securitate
- Conectivitate
- Scalabilitate
- Localizare



Probleme interconectate!

- Cel mai mare sistem conectat
- Dispozitivele mobile predomină
- Aplicațiile mobile domină traficul
- Posibilități noi, amenințari noi
- Tehnologia mobilă – parte a vieții 24/7, oriunde în lume
- Servicii suport (distribuite)

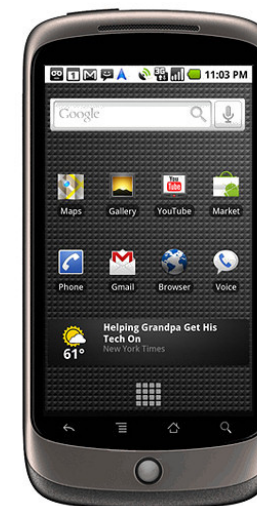

- To google: “best of CES 2016”
 - Wearables, IoT, Gamification of life, drones
- To read: **Mark Weiser, *The Computer for the 21st Century***
 - “...most profound technologies are those that disappear...into the fabric of everyday life”

- Noțiuni generale despre radio
- **Accesul la mediul radio**
 - SDMA, FDMA, TDMA, CDMA
 - CSMA/CA
- **Sisteme de comunicații mobile**
 - 2G: GSM, GPRS
 - 3G: UTRA, UMTS, HSDPA
 - 4G: LTE
- **WiFi**
 - 802.11a/b/g/n/ac/ad
 - Infrastructuri
- **Mobile IP**
 - Locator/Identifier split
 - Routing
- **Mobilitate nivel transport**
 - I-TCP, MPTCP
 - middlebox-uri
- **VoIP**
 - QoS, RTP
 - SIP
- **Descoperire servicii**
 - zeroconf, mDNS, DNS-SD
 - CDN
- **Servicii de locație**
 - Exterior: GPS, CellID
 - Interior: WiFi

pe mobil: încărcarea unei pagini

Why it takes time to download a webpage

1

User opens app.

This wakes up the radio (if idle), which sends a request to a cell tower for a channel.



0 s

2

Cell tower and device exchange control messages.

The device is promoted to the full-power state, and signaling exchange takes about 2 seconds (app is not responsive during this time).



.01 s

This 2-second setup is needed only if device is idle.

2.10 s

3

App can now request content from a webpage.

Before opening TCP connection to the webpage, DNS address lookup is first performed (if needed).

Round-trip for DNS lookup is about 100–200ms.

2.20 s

TCP connection for home page takes another 100-200 ms. Home page is returned with instructions for downloading additional objects (images, audio, video).

2.40 s

DNS lookup. One for each domain visited for first time (approx. 100-200ms).



TCP connection (100-200ms roundtrip)



2.50 s



2.60 s

TCP connection established. Data transfer can begin to download objects.



HTTP request



HTTP response

Round-trip takes 100–200ms. One per object

2.70 s

The HTTP step repeats multiple times; some object retrievals may require additional TCP, DNS steps also.

Round trips take 100-200ms each. The number & length of trips depend on:

- number of objects (some apps can have 150 objects).
- whether a new TCP connection or a DNS lookup is required.
- whether HTTP requests are sequential or pipelined.
- the number of concurrent TCP connections.

4

Completed page is displayed.

Page may start displaying before all content arrives.

Total time elapsed: 3-60 seconds*

*Actual time is highly variable, depending on whether device was idle, the amount of prefetching, number of objects and DNS lookups, number of TCP connections, distance from servers, and whether pipeline was used.



pe mobil: încărcarea unei pagini

Why it takes time to download a webpage

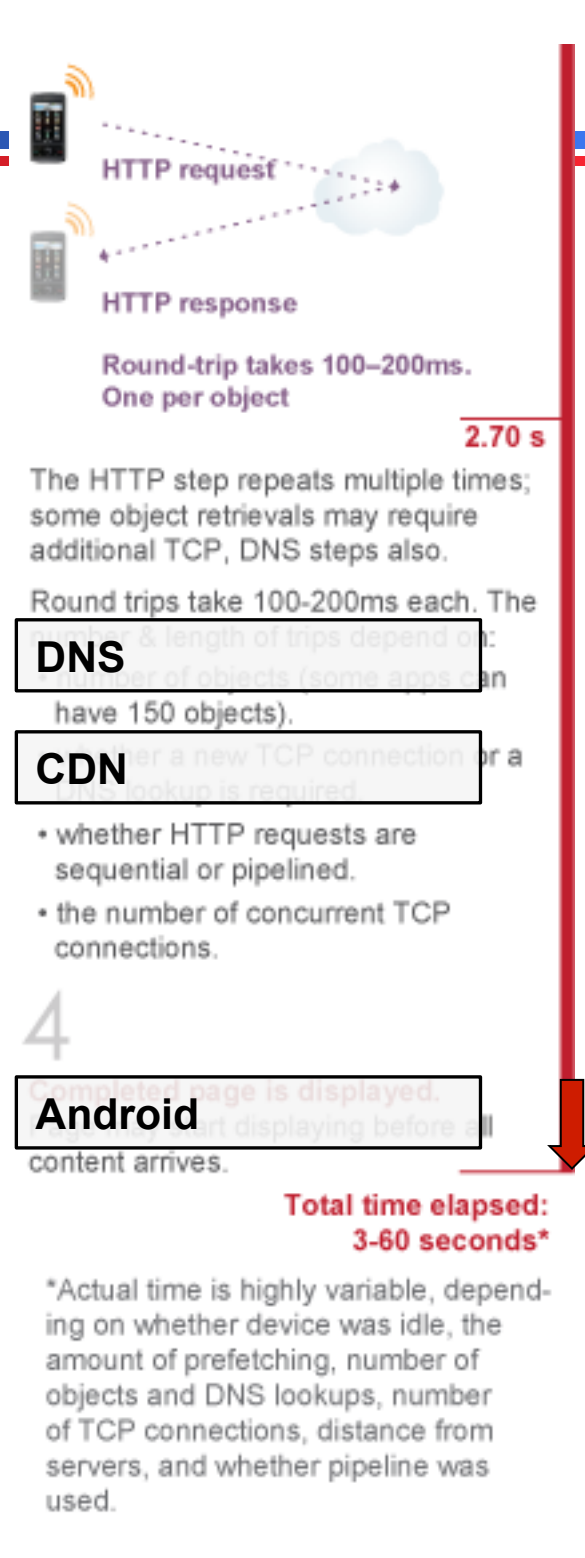
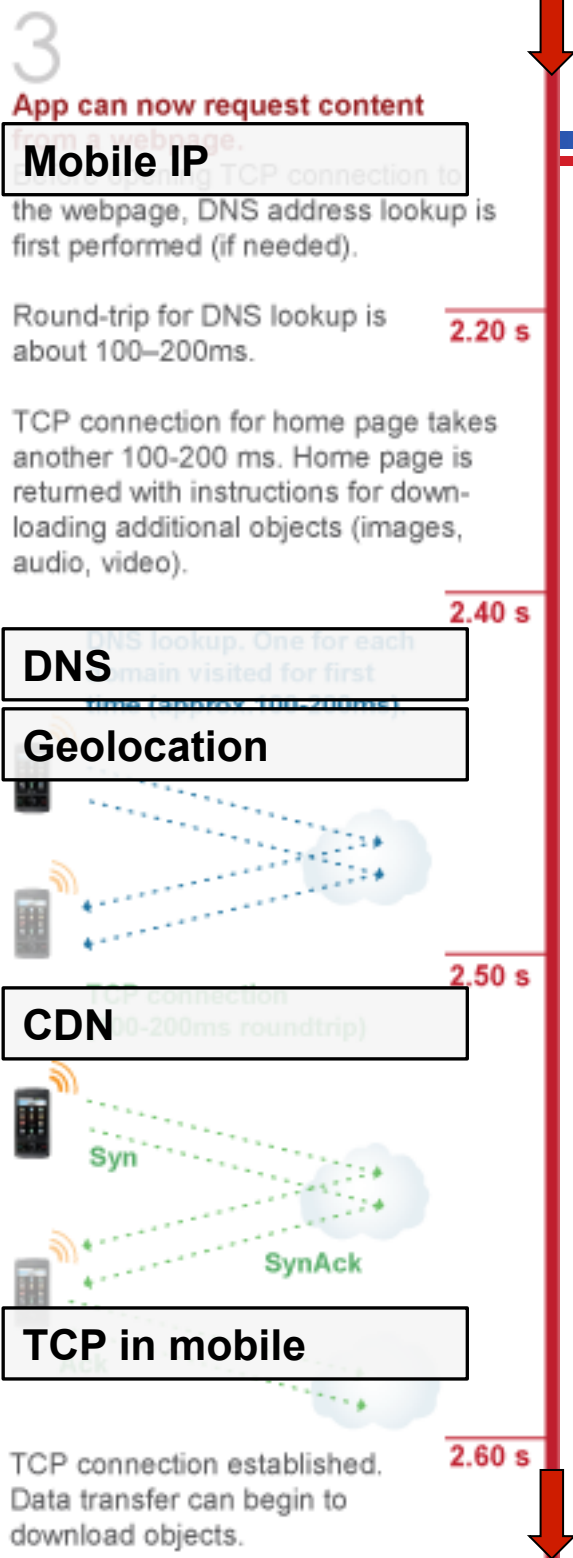
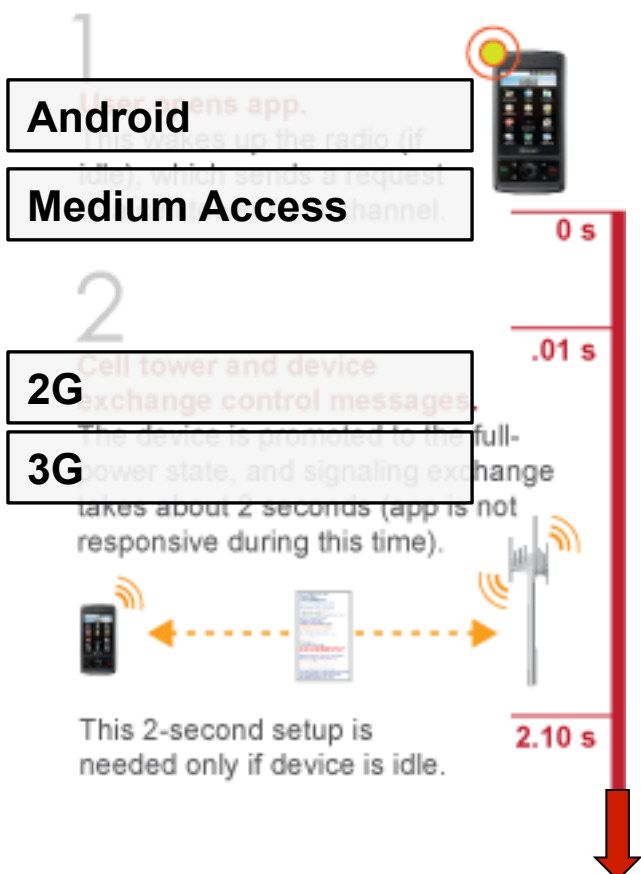

Android
Medium Access

2G
3G

Mobile IP

DNS

Geolocation

CDN

TCP in mobile

DNS

CDN

Android

App can now request content from a webpage. Establishing TCP connection to the webpage, DNS address lookup is first performed (if needed).

Round-trip for DNS lookup is about 100–200ms. **2.20 s**

TCP connection for home page takes another 100-200 ms. Home page is returned with instructions for downloading additional objects (images, audio, video). **2.40 s**

TCP connection established. Data transfer can begin to download objects. **2.60 s**



Round-trip takes 100–200ms. One per object **2.70 s**

The HTTP step repeats multiple times; some object retrievals may require additional TCP, DNS steps also.

Round trips take 100-200ms each. The number & length of trips depend on: number of objects (some apps can have 150 objects).

- whether HTTP requests are sequential or pipelined.
- the number of concurrent TCP connections.

Completed page is displayed. Content starts displaying before all content arrives.

Total time elapsed: 3-60 seconds*

*Actual time is highly variable, depending on whether device was idle, the amount of prefetching, number of objects and DNS lookups, number of TCP connections, distance from servers, and whether pipeline was used.





3GPP ACH **ACK** ACL ADSL AES AP ARQ ATIM ATM BCCH BCH BER BFSK B-ISDN
 BNEP BPSK BSC BSS BSS BTS CBR CC CCA CCCH CCH CCK CD CDN CDMA
 CGI CIDR CIF COA Codec CRC CS **CSMA** CSMA/CA CSMA/CD CTS CW DA DBPSK
 DCF DHCP DIFS **DNS** DOP DS DSL DSSS DTIM DVB ECN EDGE EIRP ESS FA
 FCH FDM FDMA FEC FHSS FIB FOMA FSK GGSN GPRS **GPS** GRE GSM HA HDLC
 HDTV HID HLR HM HO HSDPA **HTML** HTTP IAPP IBSS ICMP IEEE IETF IFS IMEI
 IMSI IP IrDA ISDN ISI I-TCP ITU-T JPEG L2CAP LAN MAC MACA MANET MH MIMO
 MPEG **MPLS** MS MSC TCP NAV NAT NFS OFDM OSS OTA PCH PCM PDA PHY PIN
 PKI PLCP PLL PMD POTS PSK PSM PSTN PUK QAM QoS QPSK RACH RCH
 RFCOMM RFID RFC RIP RPC RSS RTS **RTT** S-DMB SA SAAL SACCH SAMA SAP
 SAT SATM SC SC SCF SDM SDMA SDR SGSN SIFS SIM SIP SLP SMS SS7 SSL
 TCH TCP **TDD** TDM TDMA TOS TSF TTL UDP UE UMTS UPnP URL UTRA UWB
 VAD VBR VLR W3C WAN WCDMA **WLAN** WLL WPA2 WPAN WWAN WWW XML

Noțiuni generale despre radio



- Unități de măsură
- Atenuare
- Capacitate
- Codare, modulare
- Detecție, corecție

- **Bandă**

Fizic: MHz

Rețea: Mbps = 10^6 bps

- **Atenuare dB**

$$1 \text{ dB} = 10 \log_{10} (P_1/P_0)$$

- **Putere mW, dBm**

$$1\text{W} = 1000\text{mW} = 30\text{dBm}$$

$$1\text{mW} = 0\text{dBm}$$

$$P[\text{dBm}] = 10 \log_{10} P[\text{mW}]$$

$$P[\text{mW}] = 10^{P[\text{dBm}]/10}$$

3dB = putere dublă

mW	dBm
0	$-\infty$
0.000000000001	-100
0.0000000001	-90
0.000001	-50
0.01	-20
0.1	-10
1	0
2	3
4	6
8	9
10	10
100	20
1000	30

- Signal to Noise Ratio $SNR = S[mW]/N[mW]$
 $SNR[dB] = 10\log_{10}(S/N)$
 $= 10\log_{10}S - 10\log_{10}N =$
 $= S[dBm] - N[dBm]$

Path loss in dB (atenuare)

$$\text{dB} = 10 \log \left(\frac{P_1}{P_2} \right)$$

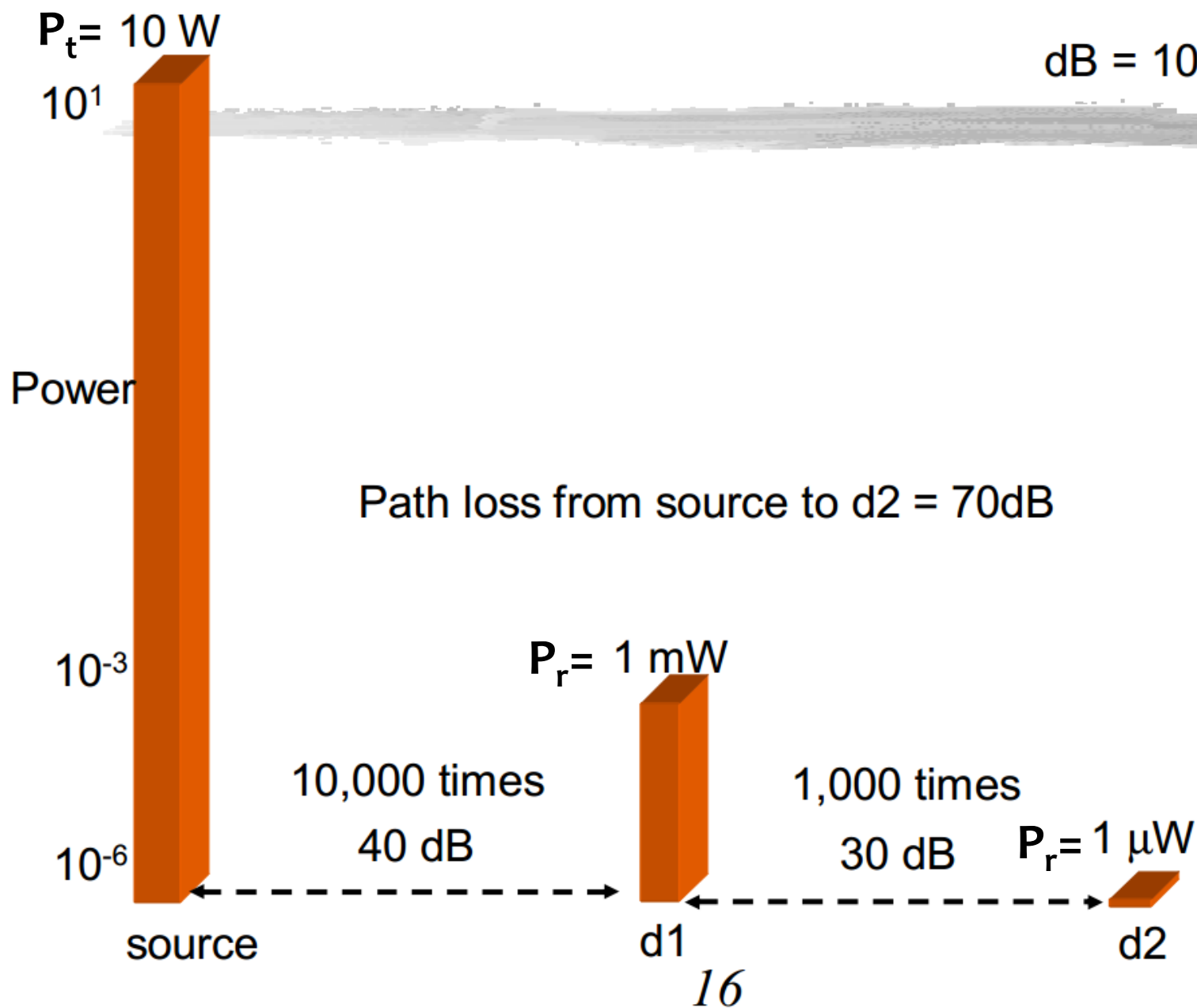

dBm (absolute measure of power)

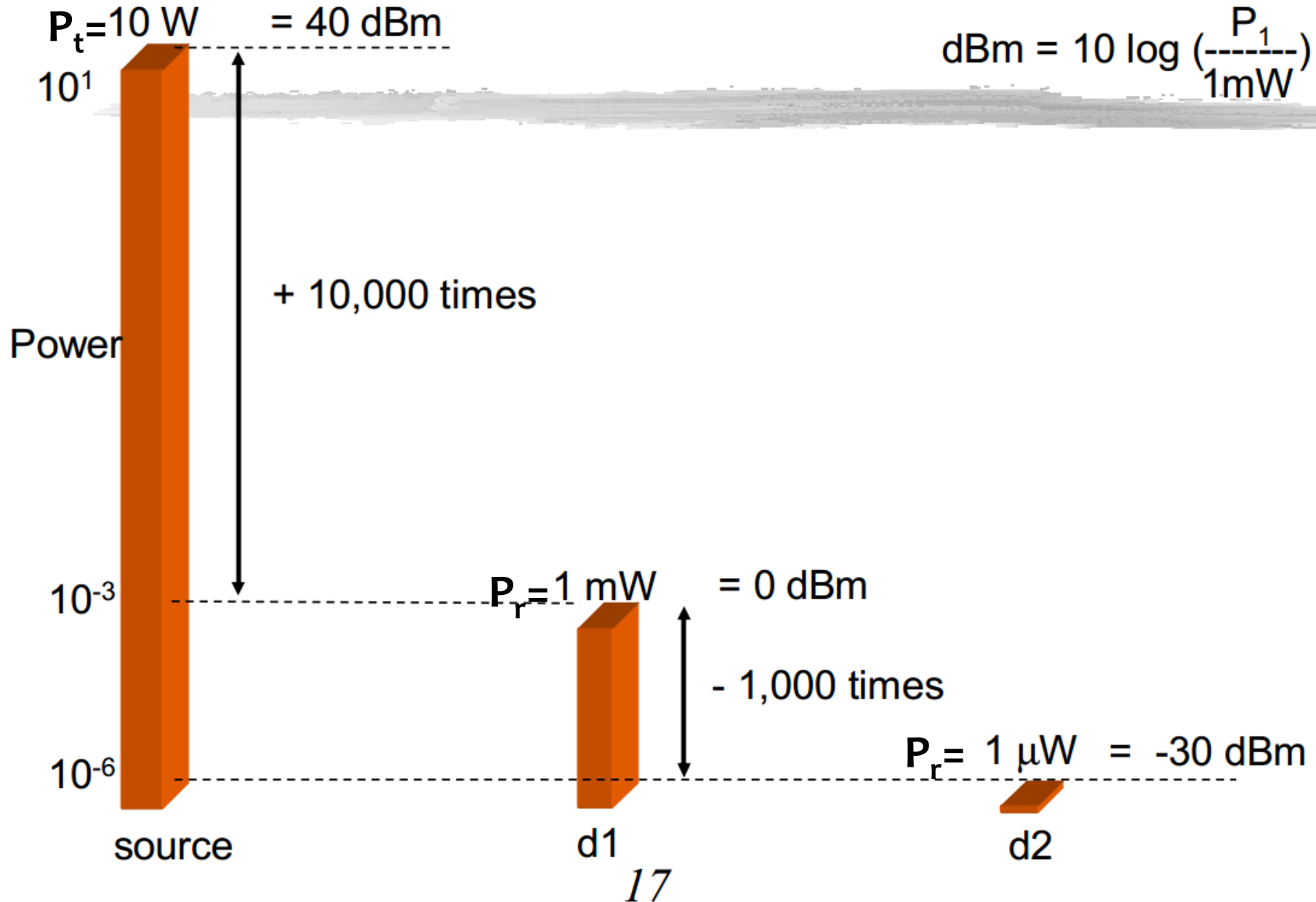

Atenuarea undelor radio



$$P_r = P_t / \text{atenuare}, \text{ unde } \text{atenuare} = (4\pi df/c)^n$$

d = distanța

f = frecvența purtătoarei

n = exponent specific mediului

c = viteza luminii

mediu	n	propagare
coridoare	1.4 – 1.9	ghid undă
Camere mari, libere	2	free space loss
Camere cu mobilă	3	FSL + multicăi
Camere încărcate	4	non LOS, difracție, împrăștiere
Între etaje	5	traversare podele, pereți

$$\begin{aligned} \text{Atenuare[dB]} &= 10 \log_{10} (4\pi df/c)^n = \\ &= 10n \log_{10}(d) + \text{Const.} \end{aligned}$$

Efect: puterea recepționată[dB] depinde logaritmic de distanță

În dBm: $P_r = P_t - \text{atenuare}$

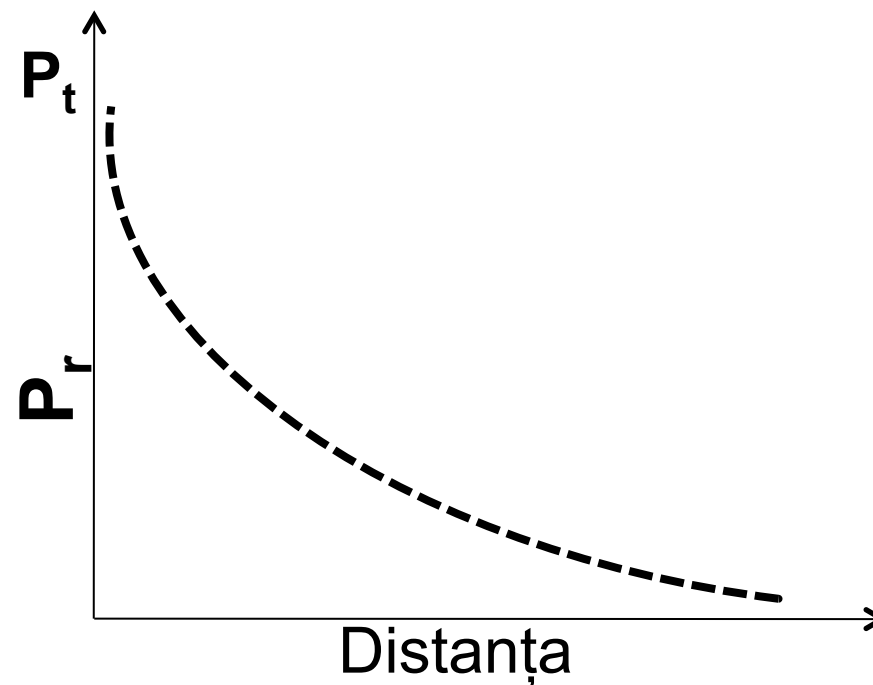

- **Bit Error Ratio (BER) = probabilitatea de eroare 1 bit**
 - 1000BASE-T : 10^{-10}
 - Fibră: 10^{-15}
 - Wireless: 10^{-6} .. **1**

- **Packet Error Ratio (PER)**
 - probabilitatea de eroare 1 pachet de L biți
 - $PER = 1 - (1 - BER)^L$

- Scop: Transferul biților prin mediu
- Codare: transformă un semnal digital în altul, *mai potrivit*
 - Control erori (FEC)
 - Bit -> chip (CDMA)
 - Împrăștiere (spread spectrum)
- Modulare/demodulare
 - conversia digital–analog-digital
- **MCS = modulation + coding scheme**
- suport L2 (temporizare, sincronizare, încadrare)

Exemplu MCS pentru WiFi 1Mbps



Codare Barker

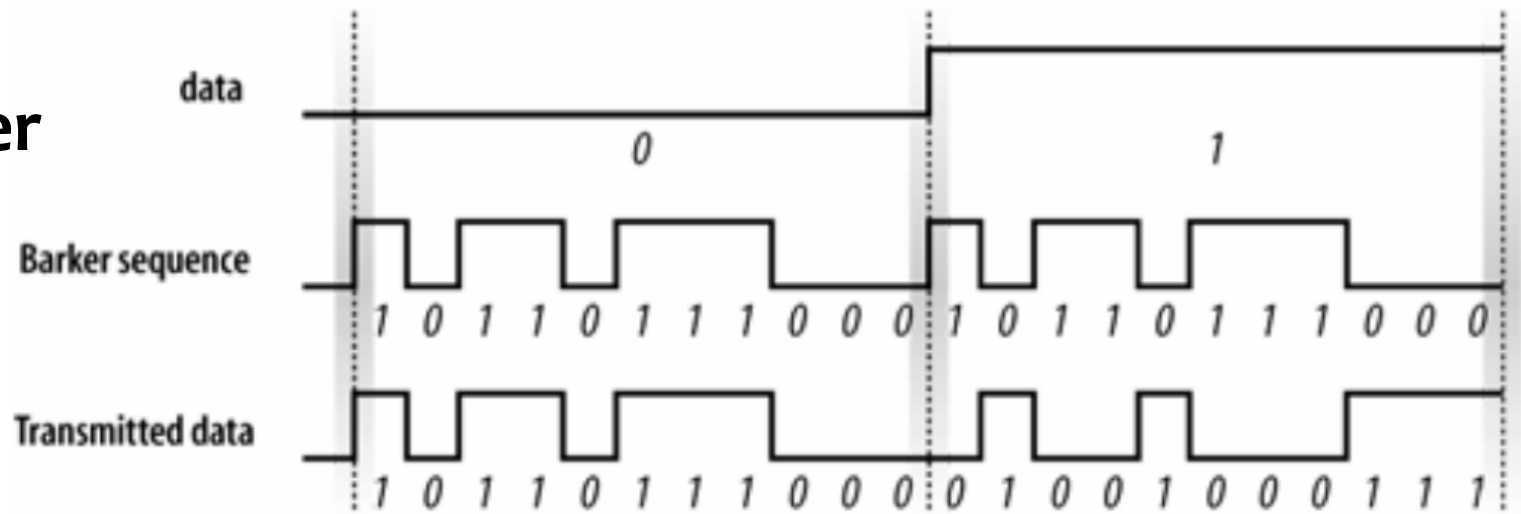

Modulare BPSK

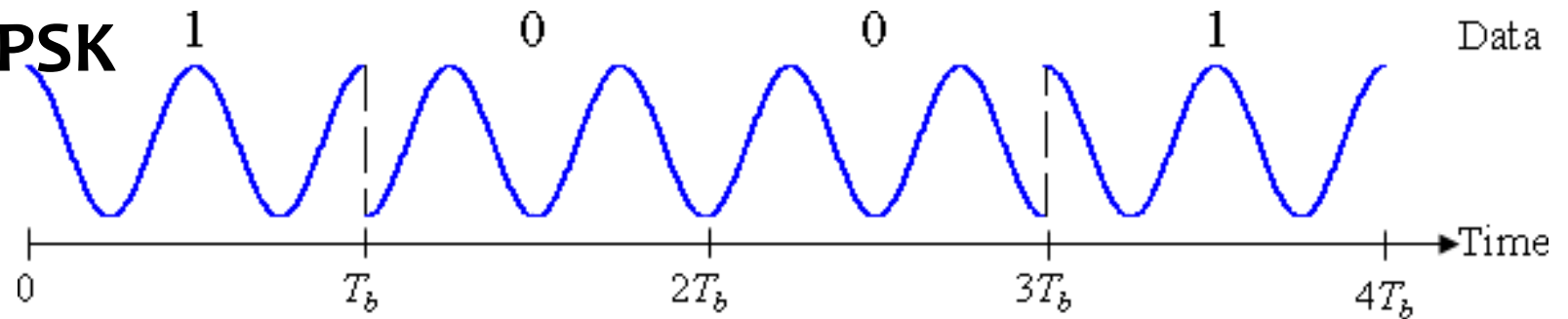

Modulation & coding scheme

- MCS = combinație de codare + modulare
- obține o rată fixă de emisie în bps
- ratele mari necesită putere mare

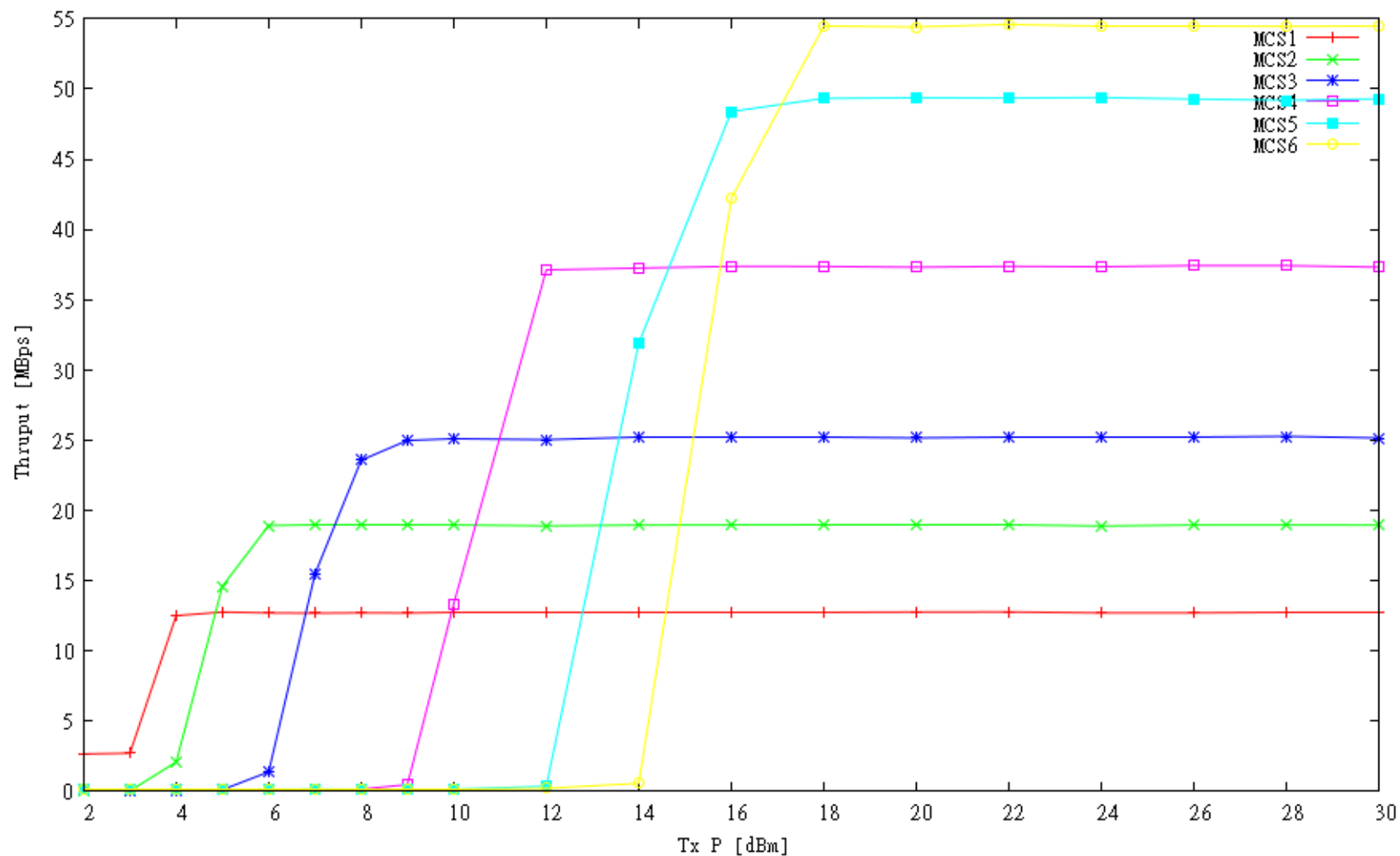

Controlul erorilor pe canale cu zgomot

ARQ, FEC, HARQ

Controlul erorilor (PHY + LL)



- Detecție

- Biți de paritate
- Checksum, CRC

- Corecție

- FEC (Forward Error Correction)
 - Coduri bloc
 - Hamming, Reed-Solomon

- ARQ (Automatic Repeat Request): Stop&Wait, GoBackN, Selective Repeat

- HARQ (Hybrid ARQ)

physical
layer

link
layer

Detecție vs Corecție



- **Ambele sunt necesare**
 - **Detecție fără corecție?**
 - **Corecție fără detecție?**
- **Detecție – overhead mic**
 - **Ethernet, WiFi: payload CRC 4 octeți**
 - **IP header checksum: 2 octeți**
 - **TCP/UDP payload checksum: 2 octeți**
- **Corecție – overhead în timp/biți**
 - **ARQ: se retransmite**
 - **FEC: se folosesc biți suplimentari**

- Codare la transmisie (FEC encoder)
 - bloc de **k** simboluri se mapează la un cuvânt de **n** simboluri
 - se emit **n** simboluri
- Decodare la recepție (FEC decoder)
 - A. din **n** simboluri primite se recuperează **k** simboluri corecte
 - B. se detectează maximum **t** erori nerecuperabile => BER
 - C. nu se detectează erori, deși ele sunt prezente
- Cod(**n**, **k**)
 - Overhead = (n-k)/k

$$BER = \frac{1}{n} \sum_{i=t+1}^n i \binom{n}{i} p^i (1-p)^{n-i}$$

$p = \text{BER necodat}$

FEC: Cod cu repetiție(3,1)



- Simbol = 1 bit
- $k = 1$ $n = 3$
- transmit 3 biți pentru 1
- votează la recepție
- corecție 1 bit eronat
- overhead: 200%

Recepție	Interpretare
000	0(fără eroare)
001	0
010	0
100	0
011	1
101	1
110	1
111	1 (fără eroare)

FEC: Cod corector Hamming(7,4)

- $k = 4$ $n = 7$
- Codează 4 biți în 7 biți
- Corectează 1 bit eronat
- Detectează 2 biți eronați
- Overhead 75%

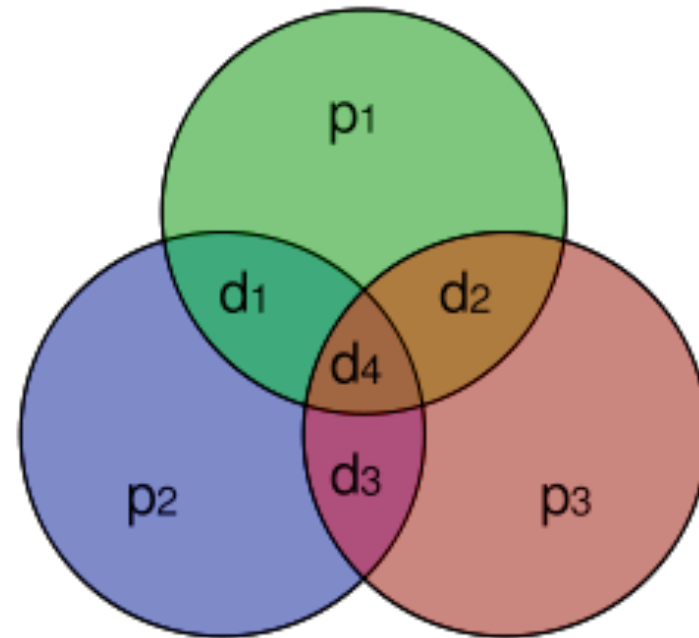

FEC: cod Reed Solomon

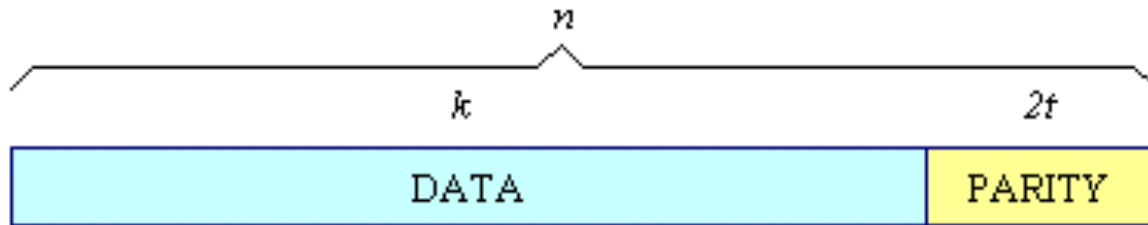

Exemplu RS(255, 223):

$s=8$ bit per simbol

$2t=32$ simboluri de paritate

$n=2^s-1$ lungimea cuvântului

- k simboluri de transmis \Rightarrow se emit $n = k + 2t = s(2^s-1)$ biți
- corectează max t erori – poziții necunoscute în n
- Overhead $(n-k)/k$
- Complexitate codec depinde de t, s

Exemplu RS(255,247)

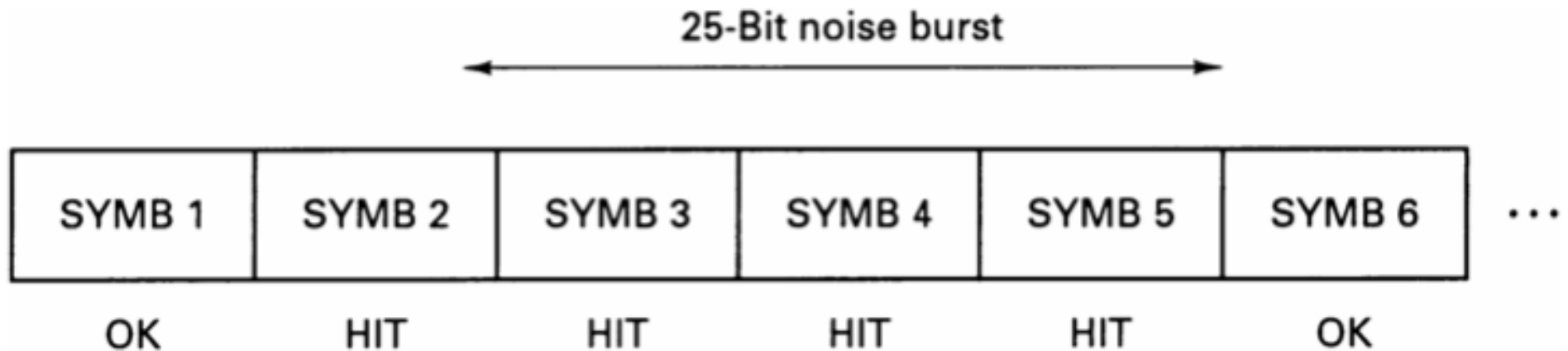

- bloc de 255 simboluri de 8 biți
- 247 originale + 8 de paritate
- **orice** 4 simboluri se pot pierde
- rezistă cu bine la o rafală de pierderi de 25 biți
- dar la 25 de biți răspândiți aleator?

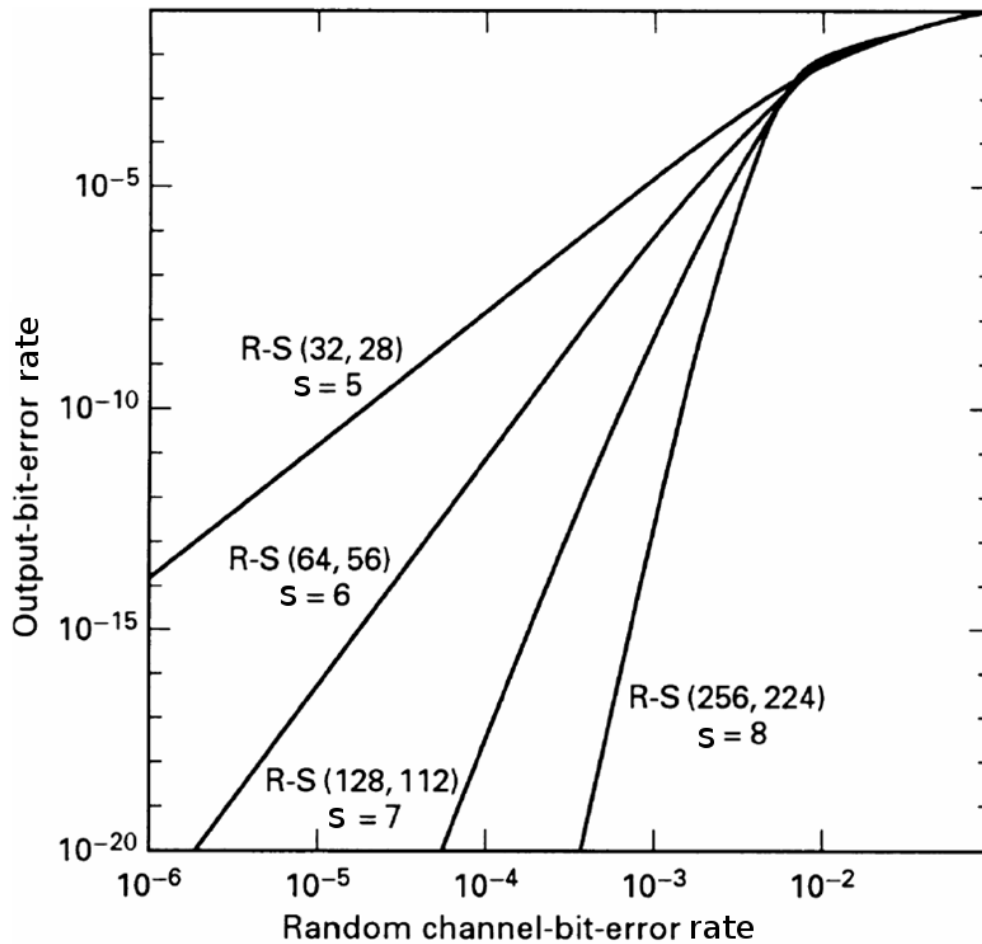

overhead fix de 1/7 cu $s=5..8$

- s crește \Rightarrow crește blocul
- s crește \Rightarrow crește rezistența

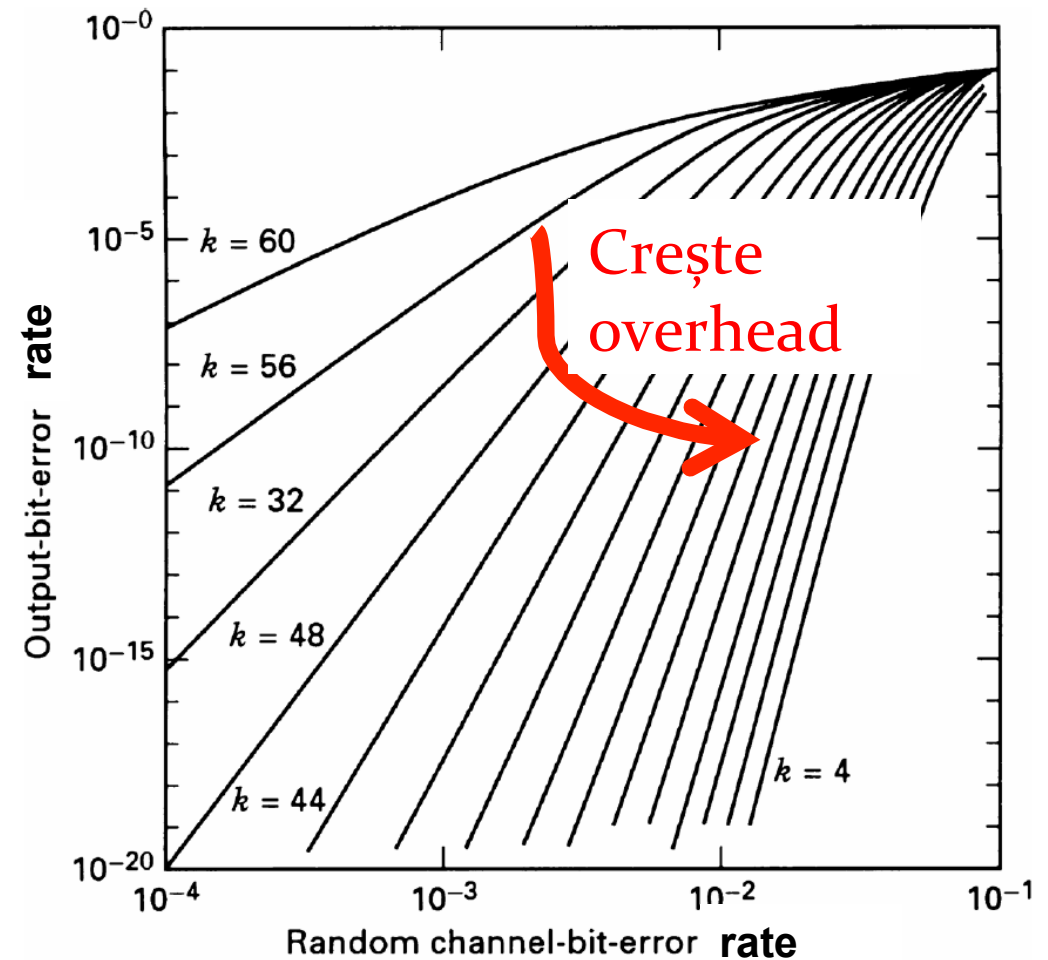

RS(64, k):

- k scade \Rightarrow crește overhead
- k scade \Rightarrow crește rezistența

- Overhead-ul depinde de capacitatea de corecție dorită
- **Funcționează până la o rată maximă de erori**
 - Necesită detecție
 - **Necesită calitatea canalului cunoscută :-)**
- **Aplicații**
 - RTT mare: spațiu (Marte OWD = 4-24 minute)
 - Stocare: informația e “uitată” la sursă

Automatic Repeat reQuest

- **necesită** detecția erorilor
- repetă cadrul/cadrele eronate
- Overhead în timp
 - RTT + timeout
 - Retransmisia propriu-zisă

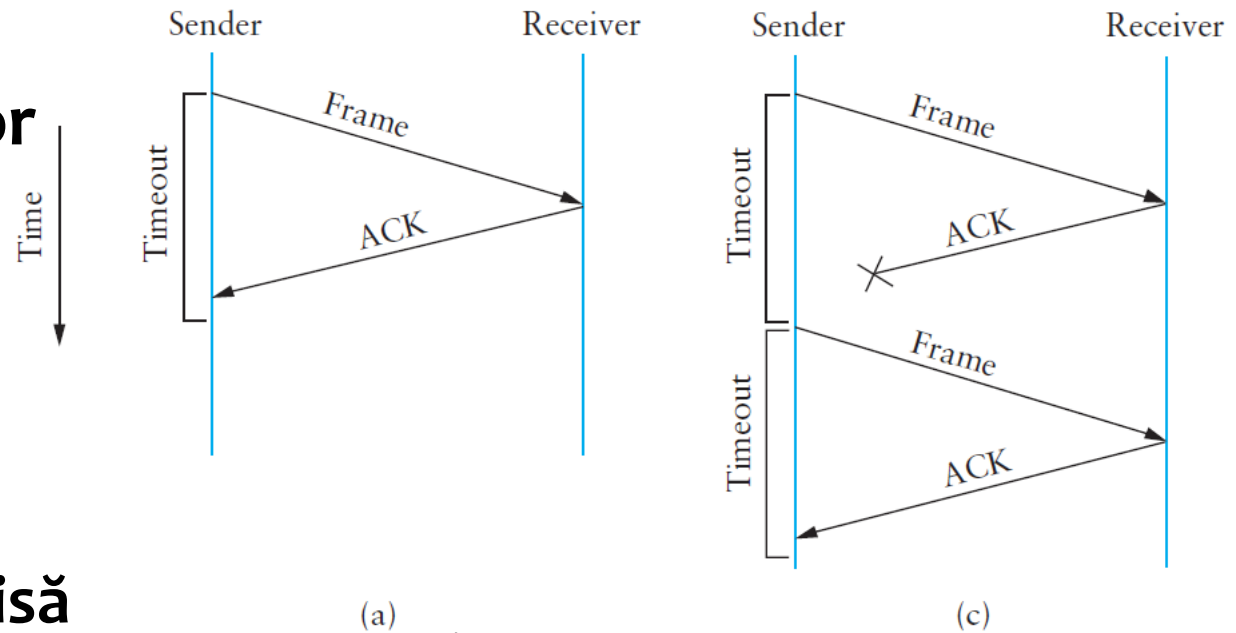

- **Stop&Wait**

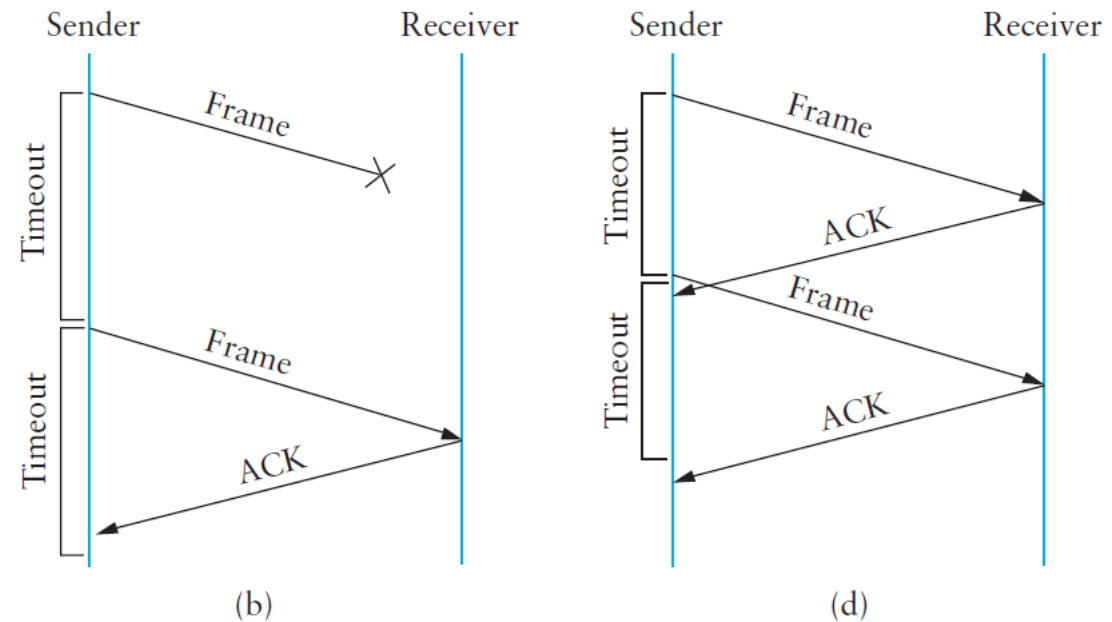

Automatic Repeat reQuest



- **necesită** detecția erorilor
- repetă cadrul/cadrele eronate
- Overhead în timp, capacitate
 - RTT + timeout
 - Retransmisia propriu-zisă
- Stop&Wait
- Window based: Go back N, Selective Repeat
- HARQ (Hybrid ARQ)
 - **Cadrele necorectate de FEC sunt recuperate cu ARQ**

PHY și LL (nivelele 1 și 2) în radio

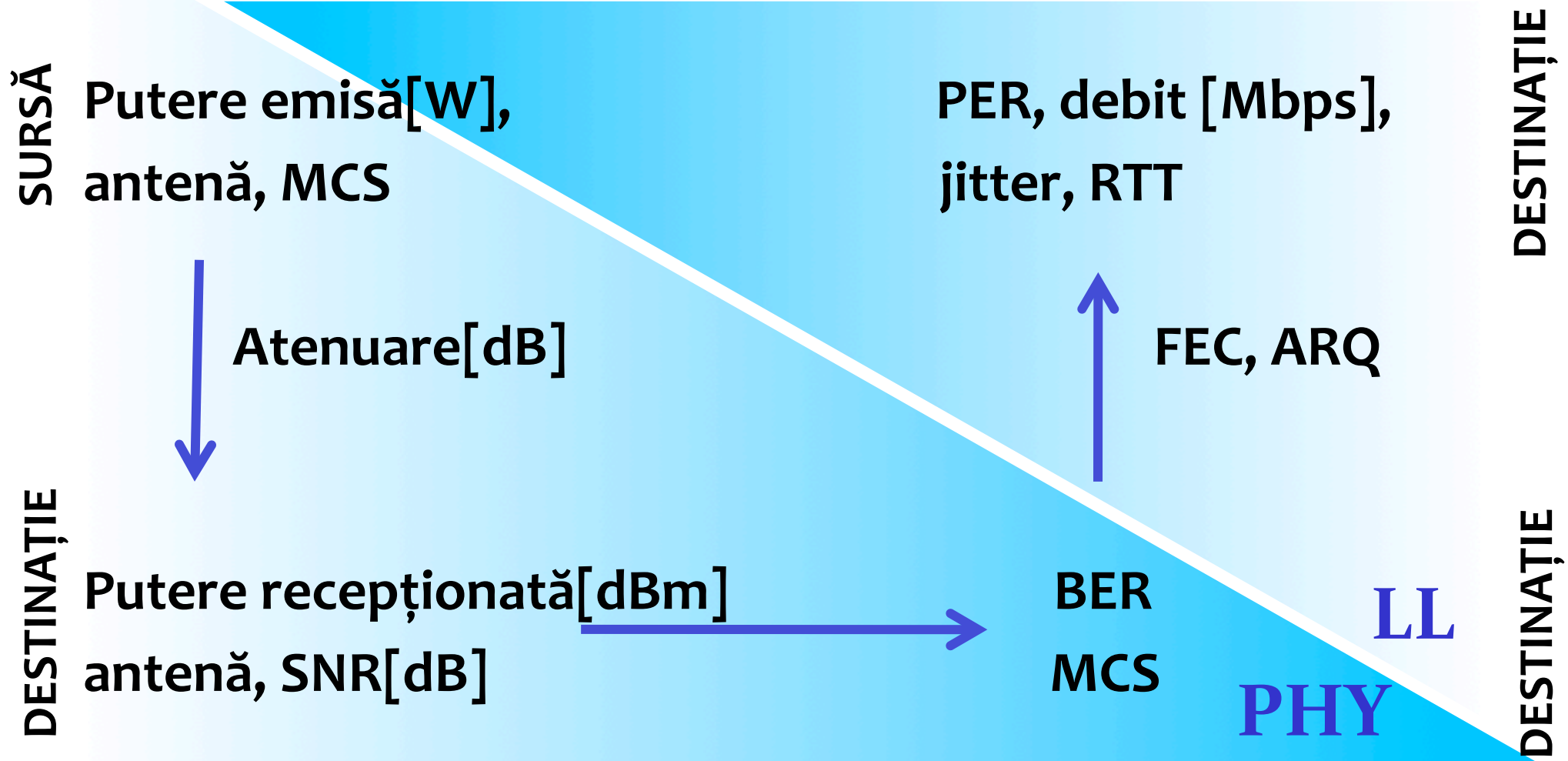

PDR = packet delivery ratio

BER = bit error rate

RTT = round trip time