

Instruction Set Nomenclature

Status Register (SREG)

SREG	Status Register
C	Carry Flag
Z	Zero Flag
N	Negative Flag
V	Two's complement overflow indicator
S	$N \oplus V$, for signed tests
H	Half Carry Flag
T	Transfer bit used by BLD and BST instructions
I	Global Interrupt Enable/Disable Flag

Registers and Operands

Rd:	Destination (and source) register in the Register File
Rr:	Source register in the Register File
R:	Result after instruction is executed
K:	Constant data
k:	Constant address
b:	Bit in the Register File or I/O Register (3-bit)
s:	Bit in the Status Register (3-bit)
X,Y,Z:	Indirect Address Register (X=R27:R26, Y=R29:R28, and Z=R31:R30)
A:	I/O location address
q:	Displacement for direct addressing (6-bit)

Table of Contents

Instruction Set Nomenclature	1
1. I/O Registers.....	13
1.1. RAMPX, RAMPY, and RAMPZ.....	13
1.2. RAMPD.....	13
1.3. EIND.....	13
1.4. Stack.....	13
1.5. Flags.....	13
2. The Program and Data Addressing Modes.....	14
2.1. Register Direct, Single Register Rd.....	14
2.2. Register Direct - Two Registers, Rd and Rr.....	15
2.3. I/O Direct.....	15
2.4. Data Direct.....	16
2.5. Data Indirect with Displacement.....	16
2.6. Data Indirect.....	17
2.7. Data Indirect with Pre-decrement.....	17
2.8. Data Indirect with Post-increment.....	18
2.9. Program Memory Constant Addressing using the LPM, ELPM, and SPM Instructions.....	18
2.10. Program Memory with Post-increment using the LPM Z+ and ELPM Z+ Instruction.....	19
2.11. Direct Program Addressing, JMP and CALL.....	19
2.12. Indirect Program Addressing, IJMP and ICALL.....	20
2.13. Relative Program Addressing, RJMP and RCALL.....	20
3. Conditional Branch Summary	21
4. Instruction Set Summary.....	22
5. ADC – Add with Carry.....	30
5.1. Description.....	30
5.2. Status Register (SREG) and Boolean Formula.....	30
6. ADD – Add without Carry.....	32
6.1. Description.....	32
6.2. Status Register (SREG) and Boolean Formula.....	32
7. ADIW – Add Immediate to Word.....	33
7.1. Description.....	33
7.2. Status Register (SREG) and Boolean Formula.....	33
8. AND – Logical AND.....	35
8.1. Description.....	35
8.2. Status Register (SREG) and Boolean Formula.....	35
9. ANDI – Logical AND with Immediate.....	36
9.1. Description.....	36

9.2. Status Register (SREG) and Boolean Formula.....	36
10. ASR – Arithmetic Shift Right	37
10.1. Description.....	37
10.2. Status Register (SREG) and Boolean Formula.....	37
11. BCLR – Bit Clear in SREG	38
11.1. Description.....	38
11.2. Status Register (SREG) and Boolean Formula.....	38
12. BLD – Bit Load from the T Flag in SREG to a Bit in Register	39
12.1. Description.....	39
12.2. Status Register (SREG) and Boolean Formula.....	39
13. BRBC – Branch if Bit in SREG is Cleared.....	40
13.1. Description.....	40
13.2. Status Register (SREG) and Boolean Formula.....	40
14. BRBS – Branch if Bit in SREG is Set.....	41
14.1. Description.....	41
14.2. Status Register (SREG) and Boolean Formula.....	41
15. BRCC – Branch if Carry Cleared.....	42
15.1. Description.....	42
15.2. Status Register (SREG) and Boolean Formula.....	42
16. BRCS – Branch if Carry Set	43
16.1. Description.....	43
16.2. Status Register (SREG) and Boolean Formula.....	43
17. BREAK – Break.....	44
17.1. Description.....	44
17.2. Status Register (SREG) and Boolean Formula.....	44
18. BREQ – Branch if Equal.	45
18.1. Description.....	45
18.2. Status Register (SREG) and Boolean Formula.....	45
19. BRGE – Branch if Greater or Equal (Signed)	46
19.1. Description.....	46
19.2. Status Register (SREG) and Boolean Formula.....	46
20. BRHC – Branch if Half Carry Flag is Cleared.....	47
20.1. Description.....	47
20.2. Status Register (SREG) and Boolean Formula.....	47
21. BRHS – Branch if Half Carry Flag is Set.....	48
21.1. Description.....	48
21.2. Status Register (SREG) and Boolean Formula.....	48

22. BRID – Branch if Global Interrupt is Disabled	49
22.1. Description.....	49
22.2. Status Register (SREG) and Boolean Formula.....	49
23. BRIE – Branch if Global Interrupt is Enabled	50
23.1. Description.....	50
23.2. Status Register (SREG) and Boolean Formula.....	50
24. BRLO – Branch if Lower (Unsigned).....	51
24.1. Description.....	51
24.2. Status Register (SREG) and Boolean Formula.....	51
25. BRLT – Branch if Less Than (Signed).....	52
25.1. Description.....	52
25.2. Status Register (SREG) and Boolean Formula.....	52
26. BRMI – Branch if Minus.	53
26.1. Description.....	53
26.2. Status Register (SREG) and Boolean Formula.....	53
27. BRNE – Branch if Not Equal	54
27.1. Description.....	54
27.2. Status Register (SREG) and Boolean Formula.....	54
28. BRPL – Branch if Plus.....	55
28.1. Description.....	55
28.2. Status Register (SREG) and Boolean Formula.....	55
29. BRSH – Branch if Same or Higher (Unsigned)	56
29.1. Description.....	56
29.2. Status Register (SREG) and Boolean Formula.....	56
30. BRTC – Branch if the T Flag is Cleared.....	57
30.1. Description.....	57
30.2. Status Register (SREG) and Boolean Formula.....	57
31. BRTS – Branch if the T Flag is Set.	58
31.1. Description.....	58
31.2. Status Register (SREG) and Boolean Formula.....	58
32. BRVC – Branch if Overflow Cleared	59
32.1. Description.....	59
32.2. Status Register (SREG) and Boolean Formula.....	59
33. BRVS – Branch if Overflow Set.	60
33.1. Description.....	60
33.2. Status Register (SREG) and Boolean Formula.....	60
34. BSET – Bit Set in SREG.....	61

34.1. Description.....	61
34.2. Status Register (SREG) and Boolean Formula.....	61
35. BST – Bit Store from Bit in Register to T Flag in SREG.....	62
35.1. Description.....	62
35.2. Status Register (SREG) and Boolean Formula.....	62
36. CALL – Long Call to a Subroutine.....	63
36.1. Description.....	63
36.2. Status Register (SREG) and Boolean Formula.....	63
37. CBI – Clear Bit in I/O Register.....	65
37.1. Description.....	65
37.2. Status Register (SREG) and Boolean Formula.....	65
38. CBR – Clear Bits in Register.....	66
38.1. Description.....	66
38.2. Status Register (SREG) and Boolean Formula.....	66
39. CLC – Clear Carry Flag.....	67
39.1. Description.....	67
39.2. Status Register (SREG) and Boolean Formula.....	67
40. CLH – Clear Half Carry Flag.....	68
40.1. Description.....	68
40.2. Status Register (SREG) and Boolean Formula.....	68
41. CLI – Clear Global Interrupt Flag.....	69
41.1. Description.....	69
41.2. Status Register (SREG) and Boolean Formula.....	69
42. CLN – Clear Negative Flag.....	70
42.1. Description.....	70
42.2. Status Register (SREG) and Boolean Formula.....	70
43. CLR – Clear Register.....	71
43.1. Description.....	71
43.2. Status Register (SREG) and Boolean Formula.....	71
44. CLS – Clear Signed Flag.....	72
44.1. Description.....	72
44.2. Status Register (SREG) and Boolean Formula.....	72
45. CLT – Clear T Flag.....	73
45.1. Description.....	73
45.2. Status Register (SREG) and Boolean Formula.....	73
46. CLV – Clear Overflow Flag.....	74
46.1. Description.....	74

46.2. Status Register (SREG) and Boolean Formula.....	74
47. CLZ – Clear Zero Flag.....	75
47.1. Description.....	75
47.2. Status Register (SREG) and Boolean Formula.....	75
48. COM – One’s Complement	76
48.1. Description.....	76
48.2. Status Register (SREG) and Boolean Formula.....	76
49. CP – Compare.....	77
49.1. Description.....	77
49.2. Status Register (SREG) and Boolean Formula.....	77
50. CPC – Compare with Carry	79
50.1. Description.....	79
50.2. Status Register (SREG) and Boolean Formula.....	79
51. CPI – Compare with Immediate	81
51.1. Description.....	81
51.2. Status Register (SREG) and Boolean Formula.....	81
52. CPSE – Compare Skip if Equal	83
52.1. Description.....	83
52.2. Status Register (SREG) and Boolean Formula.....	83
53. DEC – Decrement.....	84
53.1. Description.....	84
53.2. Status Register and Boolean Formula.....	84
54. DES – Data Encryption Standard.....	86
54.1. Description.....	86
55. EICALL – Extended Indirect Call to Subroutine	87
55.1. Description.....	87
55.2. Status Register (SREG) and Boolean Formula.....	87
56. EIJMP – Extended Indirect Jump.....	88
56.1. Description.....	88
56.2. Status Register (SREG) and Boolean Formula.....	88
57. ELPM – Extended Load Program Memory	89
57.1. Description.....	89
57.2. Status Register (SREG) and Boolean Formula.....	90
58. EOR – Exclusive OR.....	91
58.1. Description.....	91
58.2. Status Register (SREG) and Boolean Formula.....	91
59. FMUL – Fractional Multiply Unsigned.....	92

59.1. Description.....	92
59.2. Status Register (SREG) and Boolean Formula.....	92
60. FMULS – Fractional Multiply Signed.....	94
60.1. Description.....	94
60.2. Status Register (SREG) and Boolean Formula.....	94
61. FMULSU – Fractional Multiply Signed with Unsigned.....	96
61.1. Description.....	96
61.2. Status Register (SREG) and Boolean Formula.....	96
62. ICALL – Indirect Call to Subroutine.....	98
62.1. Description.....	98
62.2. Status Register (SREG) and Boolean Formula.....	98
63. IJMP – Indirect Jump.....	99
63.1. Description.....	99
63.2. Status Register (SREG) and Boolean Formula.....	99
64. IN - Load an I/O Location to Register	100
64.1. Description.....	100
64.2. Status Register (SREG) and Boolean Formula.....	100
65. INC – Increment.....	101
65.1. Description.....	101
65.2. Status Register and Boolean Formula.....	101
66. JMP – Jump.....	103
66.1. Description.....	103
66.2. Status Register (SREG) and Boolean Formula.....	103
67. LAC – Load and Clear.....	104
67.1. Description.....	104
67.2. Status Register (SREG) and Boolean Formula.....	104
68. LAS – Load and Set.....	105
68.1. Description.....	105
68.2. Status Register (SREG) and Boolean Formula.....	105
69. LAT – Load and Toggle.....	106
69.1. Description.....	106
69.2. Status Register (SREG) and Boolean Formula.....	106
70. LD – Load Indirect from Data Space to Register using Index X.....	107
70.1. Description.....	107
70.2. Status Register (SREG) and Boolean Formula.....	108
71. LD (LDD) – Load Indirect from Data Space to Register using Index Y	109
71.1. Description.....	109

71.2. Status Register (SREG) and Boolean Formula.....	110
72. LD (LDD) – Load Indirect From Data Space to Register using Index Z	112
72.1. Description.....	112
72.2. Status Register (SREG) and Boolean Formula.....	113
73. LDI – Load Immediate	115
73.1. Description.....	115
73.2. Status Register (SREG) and Boolean Formula.....	115
74. LDS – Load Direct from Data Space.....	116
74.1. Description.....	116
74.2. Status Register (SREG) and Boolean Formula.....	116
75. LDS (16-bit) – Load Direct from Data Space	117
75.1. Description.....	117
75.2. Status Register (SREG) and Boolean Formula.....	117
76. LPM – Load Program Memory	118
76.1. Description.....	118
76.2. Status Register (SREG) and Boolean Formula.....	118
77. LSL – Logical Shift Left.	120
77.1. Description.....	120
77.2. Status Register (SREG) and Boolean Formula.....	120
78. LSR – Logical Shift Right.....	122
78.1. Description.....	122
78.2. Status Register (SREG) and Boolean Formula.....	122
79. MOV – Copy Register	123
79.1. Description.....	123
79.2. Status Register (SREG) and Boolean Formula.....	123
80. MOVW – Copy Register Word.....	124
80.1. Description.....	124
80.2. Status Register (SREG) and Boolean Formula.....	124
81. MUL – Multiply Unsigned.....	125
81.1. Description.....	125
81.2. Status Register (SREG) and Boolean Formula.....	125
82. MULS – Multiply Signed.....	126
82.1. Description.....	126
82.2. Status Register (SREG) and Boolean Formula.....	126
83. MULSU – Multiply Signed with Unsigned.....	127
83.1. Description.....	127
83.2. Status Register (SREG) and Boolean Formula.....	127

84. NEG – Two’s Complement	129
84.1. Description.....	129
84.2. Status Register (SREG) and Boolean Formula.....	129
85. NOP – No Operation	131
85.1. Description.....	131
85.2. Status Register (SREG) and Boolean Formula.....	131
86. OR – Logical OR.....	132
86.1. Description.....	132
86.2. Status Register (SREG) and Boolean Formula.....	132
87. ORI – Logical OR with Immediate	133
87.1. Description.....	133
87.2. Status Register (SREG) and Boolean Formula.....	133
88. OUT – Store Register to I/O Location.....	134
88.1. Description.....	134
88.2. Status Register (SREG) and Boolean Formula.....	134
89. POP – Pop Register from Stack.....	135
89.1. Description.....	135
89.2. Status Register (SREG) and Boolean Formula.....	135
90. PUSH – Push Register on Stack.....	136
90.1. Description.....	136
90.2. Status Register (SREG) and Boolean Formula.....	136
91. RCALL – Relative Call to Subroutine.....	137
91.1. Description.....	137
91.2. Status Register (SREG) and Boolean Formula.....	137
92. RET – Return from Subroutine	139
92.1. Description.....	139
92.2. Status Register (SREG) and Boolean Formula.....	139
93. RETI – Return from Interrupt.....	140
93.1. Description.....	140
93.2. Status Register (SREG) and Boolean Formula.....	140
94. RJMP – Relative Jump.....	142
94.1. Description.....	142
94.2. Status Register (SREG) and Boolean Formula.....	142
95. ROL – Rotate Left through Carry.....	143
95.1. Description.....	143
95.2. Status Register (SREG) and Boolean Formula.....	143
96. ROR – Rotate Right through Carry	145

96.1. Description.....	145
96.2. Status Register (SREG) and Boolean Formula.....	145
97. SBC – Subtract with Carry.....	147
97.1. Description.....	147
97.2. Status Register (SREG) and Boolean Formula.....	147
98. SBCI – Subtract Immediate with Carry SBI – Set Bit in I/O Register.....	149
98.1. Description.....	149
98.2. Status Register (SREG) and Boolean Formula.....	149
99. SBI – Set Bit in I/O Register	151
99.1. Description.....	151
99.2. Status Register (SREG) and Boolean Formula.....	151
100. SBIC – Skip if Bit in I/O Register is Cleared.....	152
100.1. Description	152
100.2. Status Register (SREG) and Boolean Formula	152
101. SBIS – Skip if Bit in I/O Register is Set	153
101.1. Description	153
101.2. Status Register (SREG) and Boolean Formula	153
102. SBIW – Subtract Immediate from Word.....	154
102.1. Description	154
102.2. Status Register (SREG) and Boolean Formula	154
103. SBR – Set Bits in Register	156
103.1. Description	156
103.2. Status Register (SREG) and Boolean Formula	156
104. SBRC – Skip if Bit in Register is Cleared.....	157
104.1. Description	157
104.2. Status Register (SREG) and Boolean Formula	157
105. SBRS – Skip if Bit in Register is Set.....	158
105.1. Description	158
105.2. Status Register (SREG) and Boolean Formula	158
106. SEC – Set Carry Flag.....	159
106.1. Description	159
106.2. Status Register (SREG) and Boolean Formula	159
107. SEH – Set Half Carry Flag	160
107.1. Description	160
107.2. Status Register (SREG) and Boolean Formula	160
108. SEI – Set Global Interrupt Flag.....	161
108.1. Description	161

108.2. Status Register (SREG) and Boolean Formula	161
109. SEN – Set Negative Flag.....	162
109.1. Description	162
109.2. Status Register (SREG) and Boolean Formula	162
110. SER – Set all Bits in Register.....	163
110.1. Description.....	163
110.2. Status Register (SREG) and Boolean Formula.....	163
111. SES – Set Signed Flag.....	164
111.1. Description.....	164
111.2. Status Register (SREG) and Boolean Formula.....	164
112. SET – Set T Flag.....	165
112.1. Description.....	165
112.2. Status Register (SREG) and Boolean Formula.....	165
113. SEV – Set Overflow Flag.	166
113.1. Description.....	166
113.2. Status Register (SREG) and Boolean Formula.....	166
114. SEZ – Set Zero Flag.....	167
114.1. Description.....	167
114.2. Status Register (SREG) and Boolean Formula.....	167
115. SLEEP.	168
115.1. Description.....	168
115.2. Status Register (SREG) and Boolean Formula.....	168
116. SPM – Store Program Memory.....	169
116.1. Description.....	169
116.2. Status Register (SREG) and Boolean Formula.....	169
117. SPM #2 – Store Program Memory	171
117.1. Description.....	171
117.2. Status Register (SREG) and Boolean Formula.....	171
118. ST – Store Indirect From Register to Data Space using Index X.....	173
118.1. Description.....	173
118.2. Status Register (SREG) and Boolean Formula.....	174
119. ST (STD) – Store Indirect From Register to Data Space using Index Y	175
119.1. Description.....	175
119.2. Status Register (SREG) and Boolean Formula.....	176
120. ST (STD) – Store Indirect From Register to Data Space using Index Z.	177
120.1. Description	177
120.2. Status Register (SREG) and Boolean Formula	178

121. STS – Store Direct to Data Space.	179
121.1. Description	179
121.2. Status Register (SREG) and Boolean Formula	179
122. STS (16-bit) – Store Direct to Data Space.....	180
122.1. Description	180
122.2. Status Register (SREG) and Boolean Formula	180
123. SUB – Subtract Without Carry.....	181
123.1. Description	181
123.2. Status Register and Boolean Formula	181
124. SUBI – Subtract Immediate.....	183
124.1. Description	183
124.2. Status Register and Boolean Formula	183
125. SWAP – Swap Nibbles	185
125.1. Description	185
125.2. Status Register (SREG) and Boolean Formula	185
126. TST – Test for Zero or Minus.....	186
126.1. Description	186
126.2. Status Register (SREG) and Boolean Formula	186
127. WDR – Watchdog Reset.	187
127.1. Description	187
127.2. Status Register (SREG) and Boolean Formula	187
128. XCH – Exchange	188
128.1. Description	188
128.2. Status Register (SREG) and Boolean Formula	188
129. Datasheet Revision History.....	189
129.1. Rev.0856L - 11/2016	189
129.2. Rev.0856K - 04/2016.....	189
129.3. Rev.0856J - 07/2014.....	189
129.4. Rev.0856I – 07/2010.....	189
129.5. Rev.0856H – 04/2009.....	189
129.6. Rev.0856G – 07/2008.....	190
129.7. Rev.0856F – 05/2008	190

1. I/O Registers

1.1. RAMPX, RAMPY, and RAMPZ

Registers concatenated with the X-, Y-, and Z-registers enabling indirect addressing of the whole data space on MCUs with more than 64KB data space, and constant data fetch on MCUs with more than 64KB program space.

1.2. RAMPD

Register concatenated with the Z-register enabling direct addressing of the whole data space on MCUs with more than 64KB data space.

1.3. EIND

Register concatenated with the Z-register enabling indirect jump and call to the whole program space on MCUs with more than 64K words (128KB) program space.

1.4. Stack

STACK Stack for return address and pushed registers

SP Stack Pointer to STACK

1.5. Flags

— Flag affected by instruction

0 Flag cleared by instruction

1 Flag set by instruction

- Flag not affected by instruction

2. The Program and Data Addressing Modes

The AVR® Enhanced RISC microcontroller supports powerful and efficient addressing modes for access to the Program memory (Flash) and Data memory (SRAM, Register file, I/O Memory, and Extended I/O Memory). This chapter describes the various addressing modes supported by the AVR architecture. In the following figures, OP means the operation code part of the instruction word. To simplify, not all figures show the exact location of the addressing bits. To generalize, the abstract terms RAMEND and FLASHEND have been used to represent the highest location in data and program space, respectively.

Note: Not all addressing modes are present in all devices. Refer to the device specific instruction summary.

2.1. Register Direct, Single Register Rd

Figure 2-1. Direct Single Register Addressing

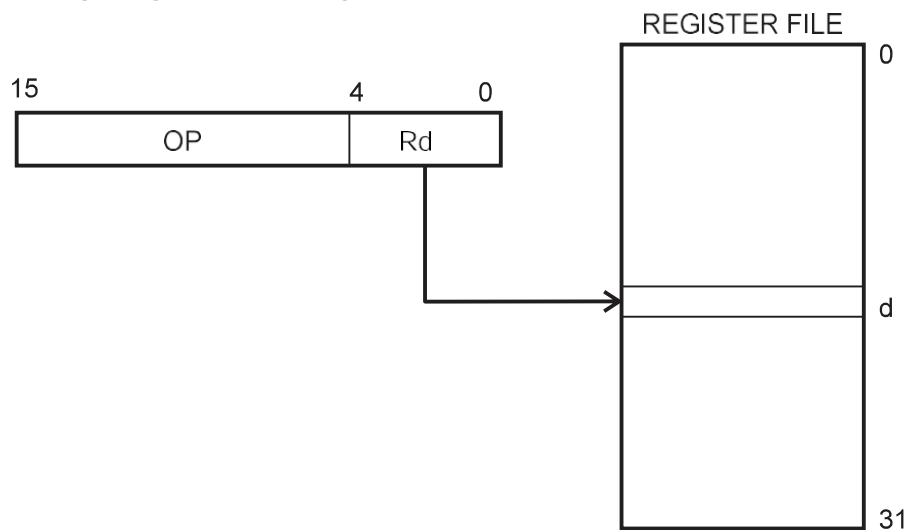

The operand is contained in register d (Rd).

2.2. Register Direct - Two Registers, Rd and Rr

Figure 2-2. Direct Register Addressing, Two Registers

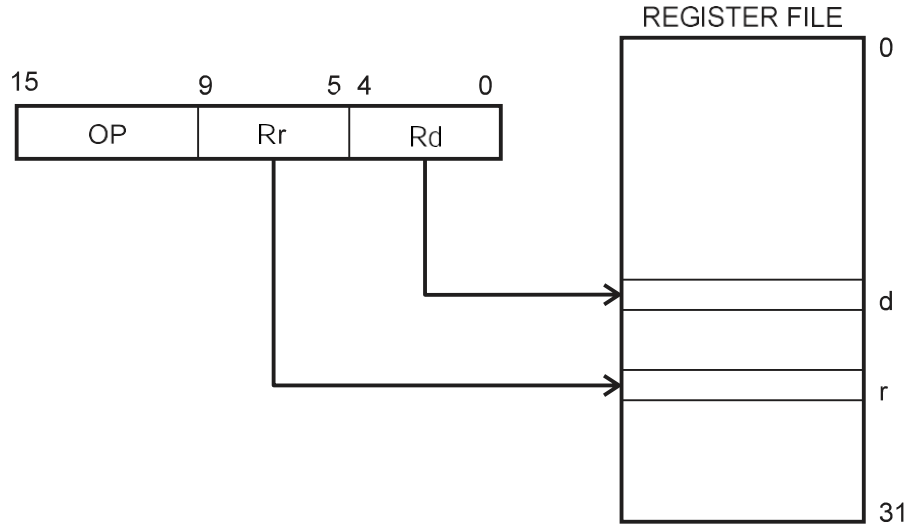

Operands are contained in register r (Rr) and d (Rd). The result is stored in register d (Rd).

2.3. I/O Direct

Figure 2-3. I/O Direct Addressing

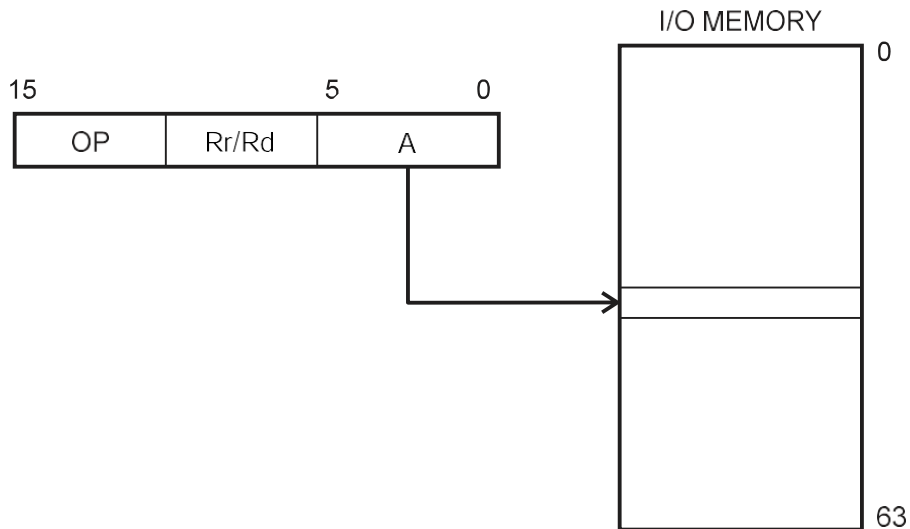

Operand address is contained in six bits of the instruction word. n is the destination or source register address.

Note: Some complex AVR Microcontrollers have more peripheral units than can be supported within the 64 locations reserved in the opcode for I/O direct addressing. The extended I/O memory from address 64 to 255 can only be reached by data addressing, not I/O addressing.

2.4. Data Direct

Figure 2-4. Direct Data Addressing

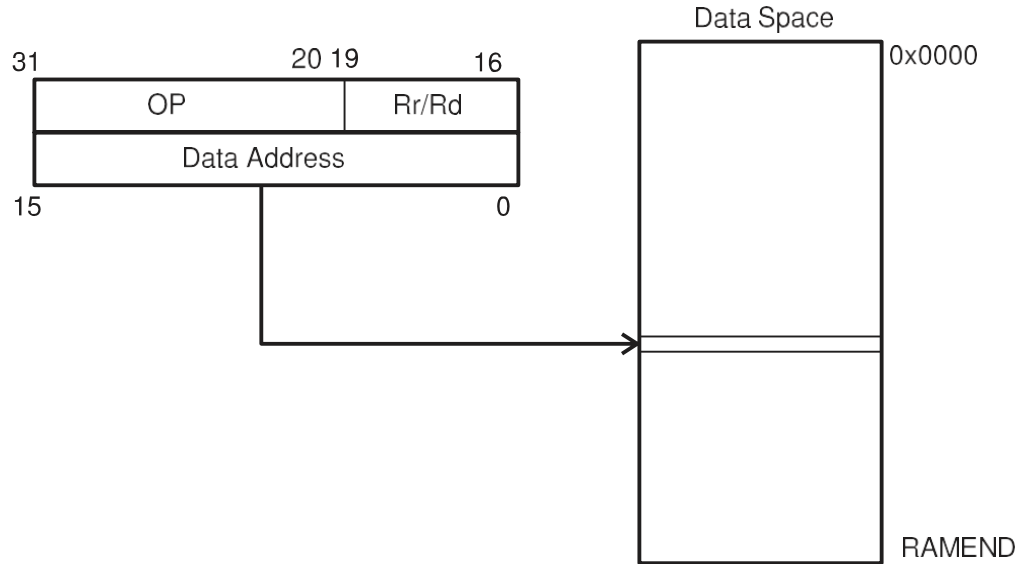

A 16-bit Data Address is contained in the 16 LSBs of a two-word instruction. Rr/Rd specify the destination or source register.

2.5. Data Indirect with Displacement

Figure 2-5. Data Indirect with Displacement

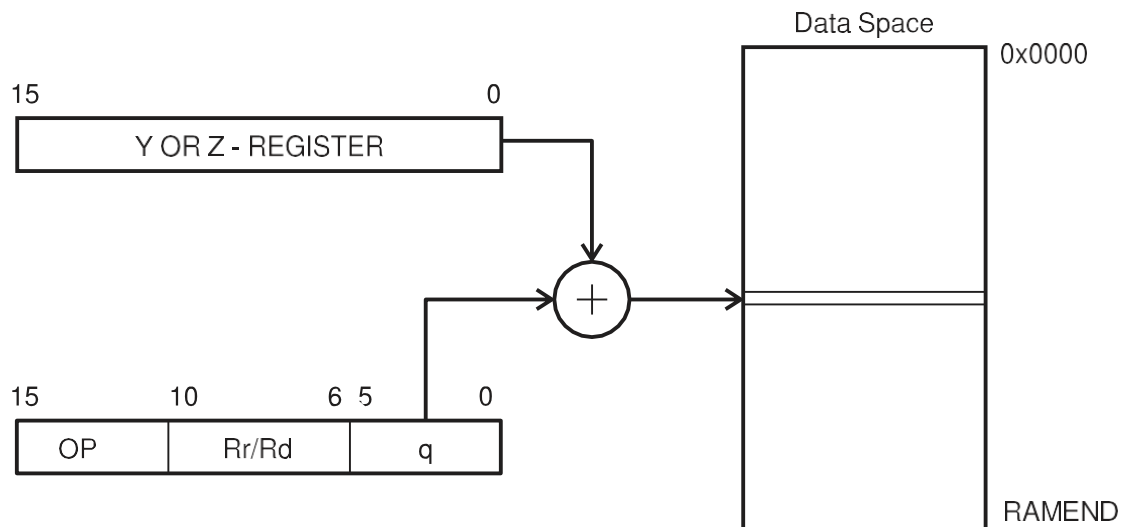

Operand address is the result of the Y- or Z-register contents added to the address contained in six bits of the instruction word. Rr/Rd specify the destination or source register.

2.6. Data Indirect

Figure 2-6. Data Indirect Addressing

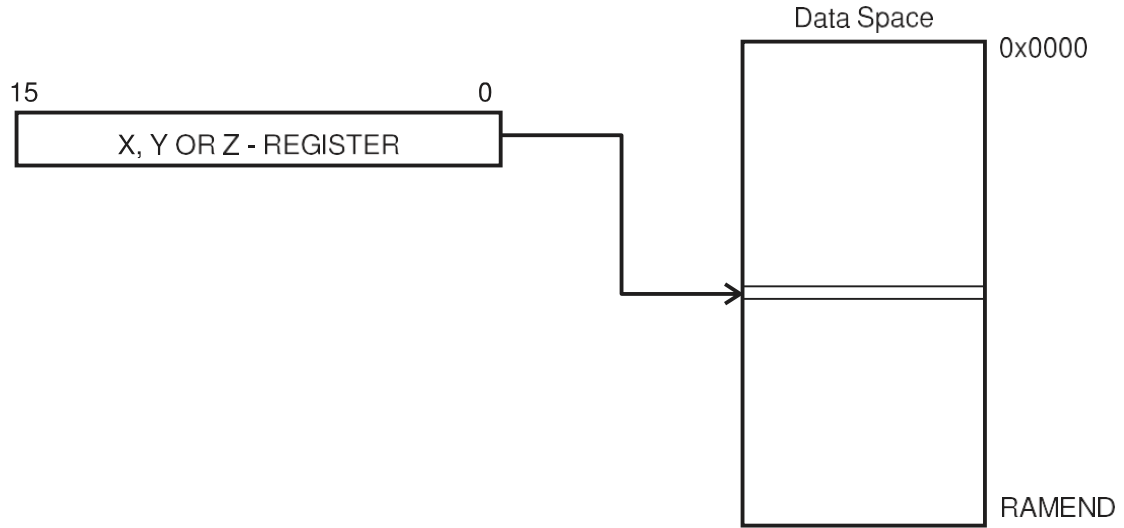

Operand address is the contents of the X-, Y-, or the Z-register. In AVR devices without SRAM, Data Indirect Addressing is called Register Indirect Addressing. Register Indirect Addressing is a subset of Data Indirect Addressing since the data space from 0 to 31 is the Register File.

2.7. Data Indirect with Pre-decrement

Figure 2-7. Data Indirect Addressing with Pre-decrement

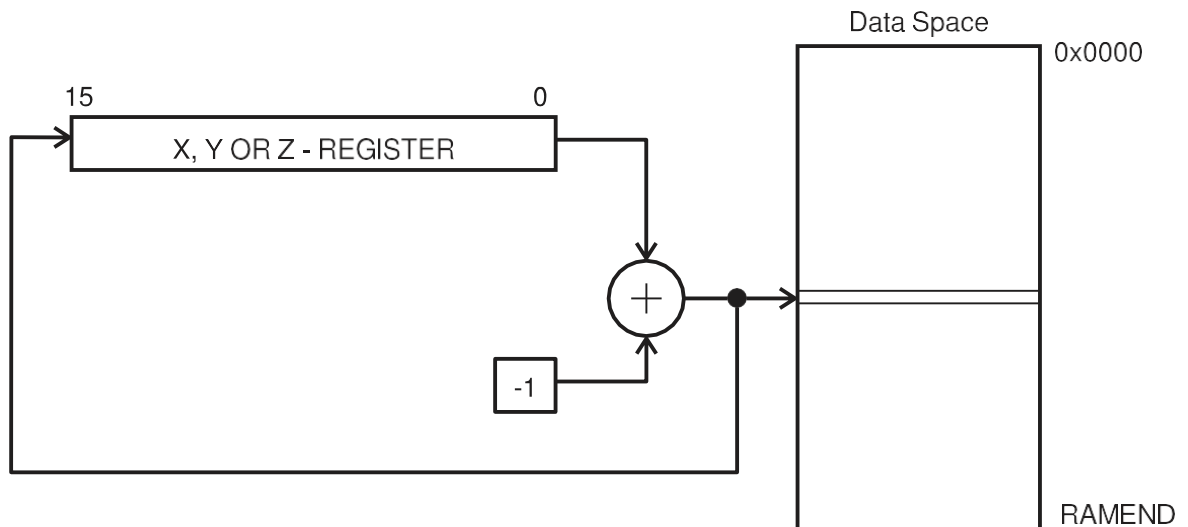

The X-, Y-, or the Z-register is decremented before the operation. Operand address is the decremented contents of the X-, Y-, or the Z-register.

2.8. Data Indirect with Post-increment

Figure 2-8. Data Indirect Addressing with Post-increment

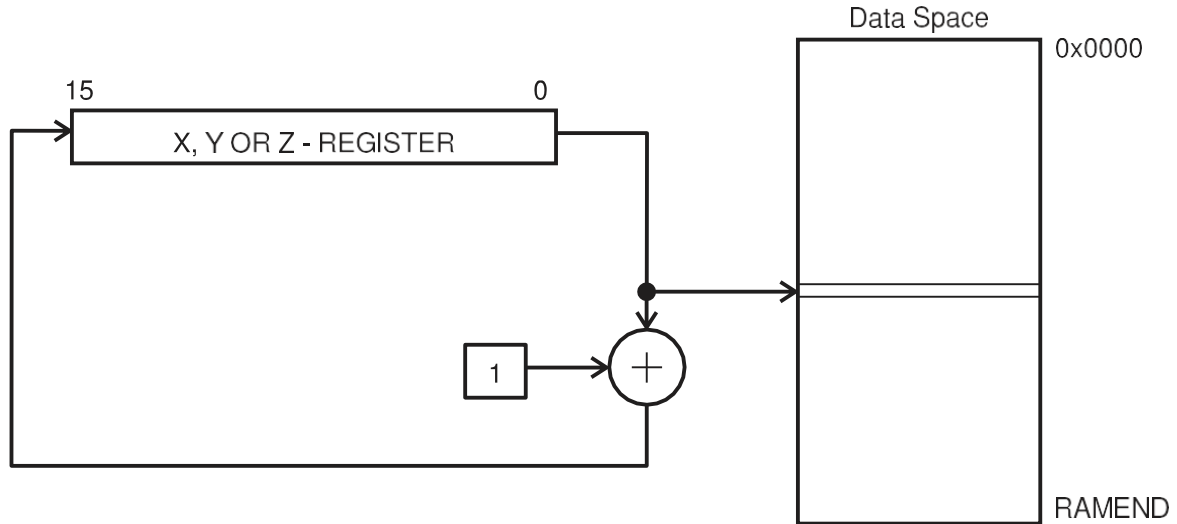

The X-, Y-, or the Z-register is incremented after the operation. Operand address is the content of the X-, Y-, or the Z-register prior to incrementing.

2.9. Program Memory Constant Addressing using the LPM, ELPM, and SPM Instructions

Figure 2-9. Program Memory Constant Addressing

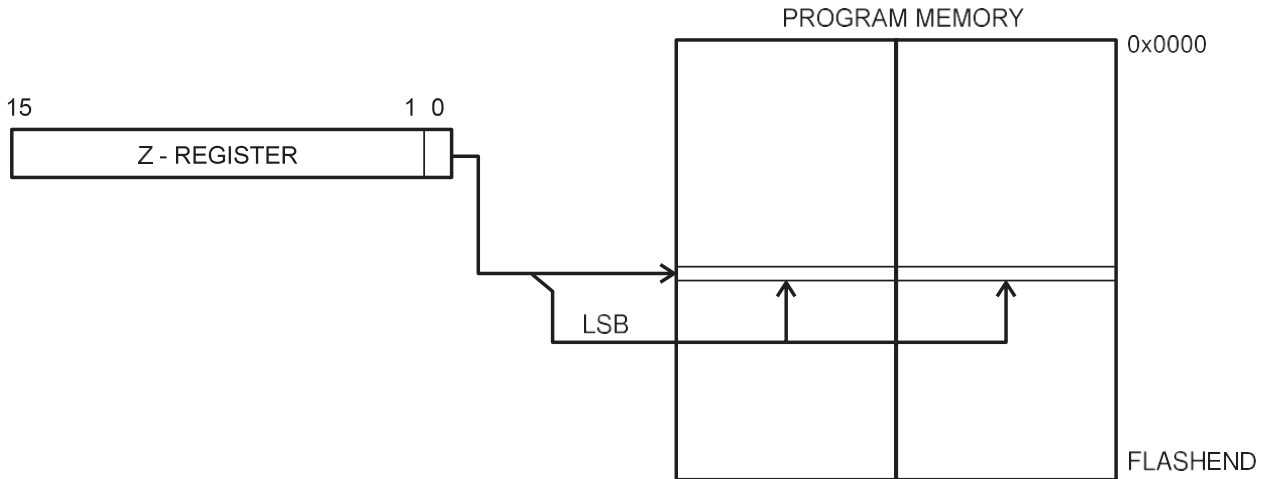

Constant byte address is specified by the Z-register contents. The 15 MSBs select word address. For LPM, the LSB selects low byte if cleared (LSB = 0) or high byte if set (LSB = 1). For SPM, the LSB should be cleared. If ELPM is used, the RAMPZ Register is used to extend the Z-register.

2.10. Program Memory with Post-increment using the LPM Z+ and ELPM Z+ Instruction

Figure 2-10. Program Memory Addressing with Post-increment

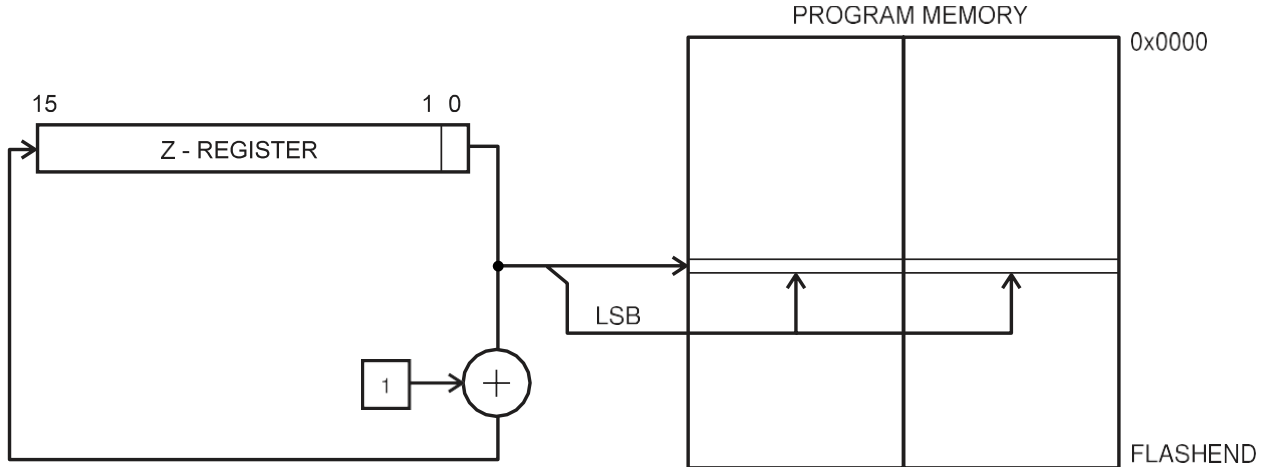

Constant byte address is specified by the Z-register contents. The 15 MSBs select word address. The LSB selects low byte if cleared (LSB = 0) or high byte if set (LSB = 1). If ELPM Z+ is used, the RAMPZ Register is used to extend the Z-register.

2.11. Direct Program Addressing, JMP and CALL

Figure 2-11. Direct Program Memory Addressing

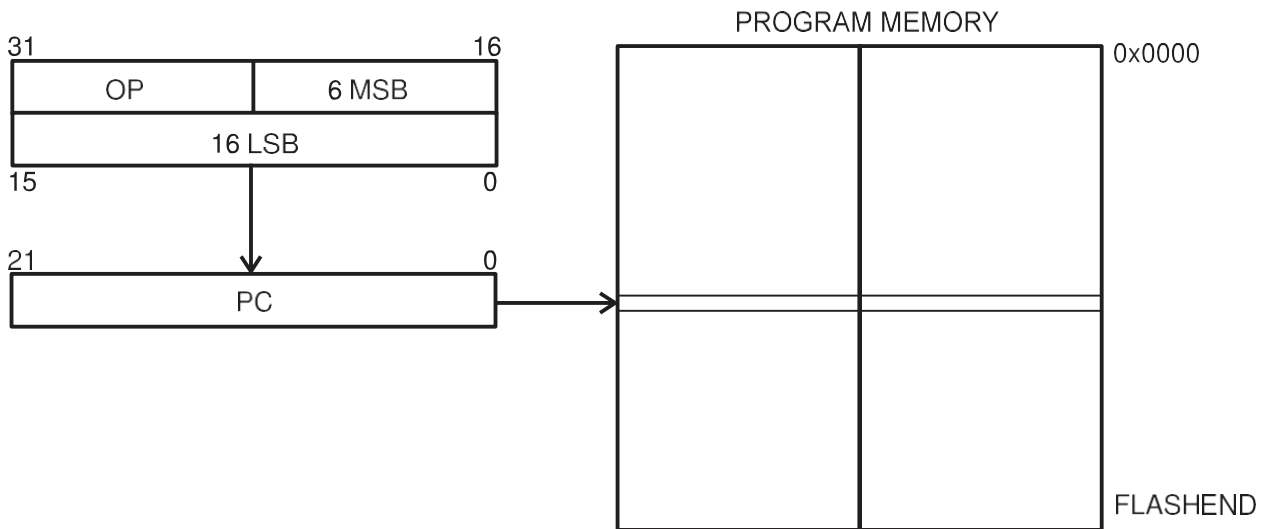

Program execution continues at the address immediate in the instruction word.

2.12. Indirect Program Addressing, IJMP and ICALL

Figure 2-12. Indirect Program Memory Addressing

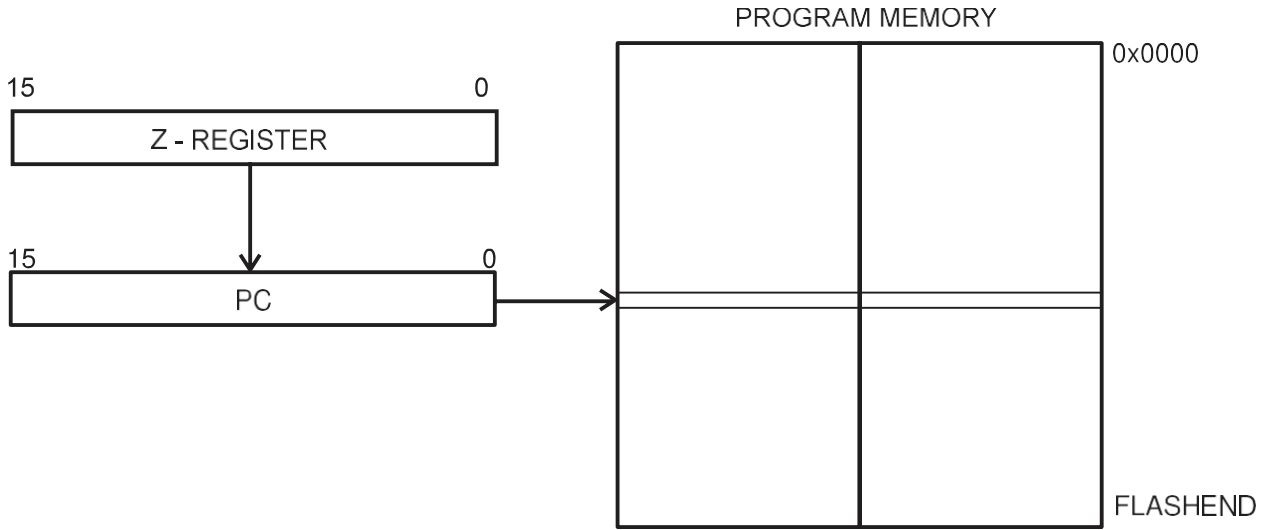

Program execution continues at address contained by the Z-register (i.e., the PC is loaded with the contents of the Z-register).

2.13. Relative Program Addressing, RJMP and RCALL

Figure 2-13. Relative Program Memory Addressing

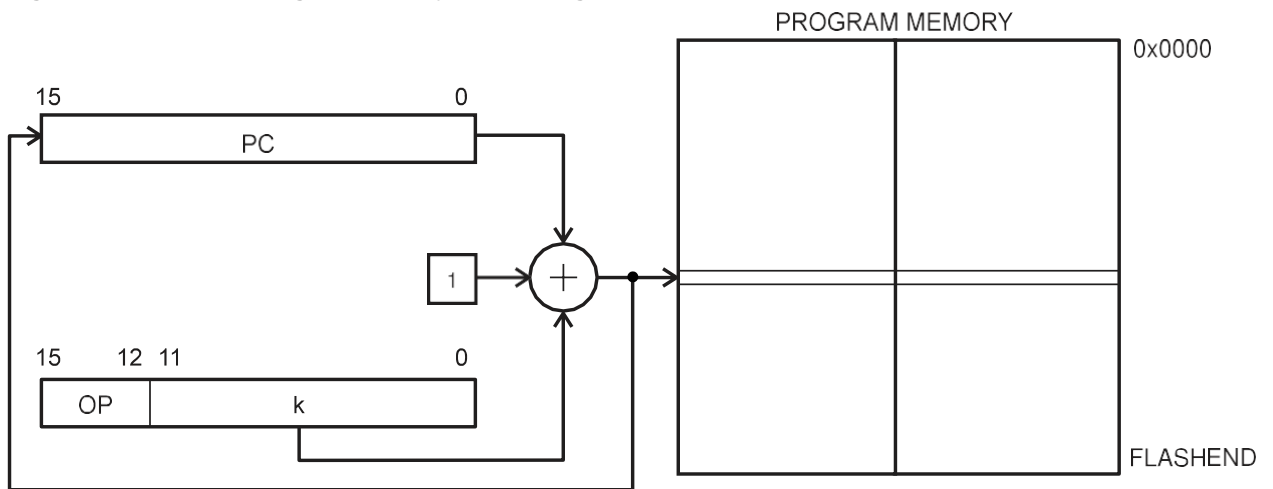

Program execution continues at address $PC + k + 1$. The relative address k is from -2048 to 2047.

3. Conditional Branch Summary

Test	Boolean	Mnemonic	Complementary	Boolean	Mnemonic	Comment
$R_d > R_r$	$Z \cdot (N \oplus V) = 0$	BRLT ⁽¹⁾	$R_d \leq R_r$	$Z + (N \oplus V) = 1$	BRGE*	Signed
$R_d \geq R_r$	$(N \oplus V) = 0$	BRGE	$R_d < R_r$	$(N \oplus V) = 1$	BRLT	Signed
$R_d = R_r$	$Z = 1$	BREQ	$R_d \neq R_r$	$Z = 0$	BRNE	Signed
$R_d \leq R_r$	$Z + (N \oplus V) = 1$	BRGE ⁽¹⁾	$R_d > R_r$	$Z \cdot (N \oplus V) = 0$	BRLT*	Signed
$R_d < R_r$	$(N \oplus V) = 1$	BRLT	$R_d \geq R_r$	$(N \oplus V) = 0$	BRGE	Signed
$R_d > R_r$	$C + Z = 0$	BRLO ⁽¹⁾	$R_d \leq R_r$	$C + Z = 1$	BRSH*	Unsigned
$R_d \geq R_r$	$C = 0$	BRSH/ BRCC	$R_d < R_r$	$C = 1$	BRLO/BRCS	Unsigned
$R_d = R_r$	$Z = 1$	BREQ	$R_d \neq R_r$	$Z = 0$	BRNE	Unsigned
$R_d \leq R_r$	$C + Z = 1$	BRSH ⁽¹⁾	$R_d > R_r$	$C + Z = 0$	BRLO*	Unsigned
$R_d < R_r$	$C = 1$	BRLO/BRCS	$R_d \geq R_r$	$C = 0$	BRSH/BRCC	Unsigned
Carry	$C = 1$	BRCS	No carry	$C = 0$	BRCC	Simple
Negative	$N = 1$	BRMI	Positive	$N = 0$	BRPL	Simple
Overflow	$V = 1$	BRVS	No overflow	$V = 0$	BRVC	Simple
Zero	$Z = 1$	BREQ	Not zero	$Z = 0$	BRNE	Simple

Note: Interchange R_d and R_r in the operation before the test, i.e., CP $R_d, R_r \rightarrow$ CP R_r, R_d .

4. Instruction Set Summary

Several updates of the AVR CPU during its lifetime has resulted in different flavors of the instruction set, especially for the timing of the instructions. Machine code level of compatibility is intact for all CPU versions with a very few exceptions related to the Reduced Core (AVRrc), though not all instructions are included in the instruction set for all devices. The table below contains the major versions of the AVR 8-bit CPUs. In addition to the different versions, there are differences dependent of the size of the device memory map. Typically these differences are handled by a C/EC++ compiler, but users that are porting code should be aware that the code execution can vary slightly in number of clock cycles.

Table 4-1. Versions of AVR 8-bit CPU

Name	Device Series	Description
AVR	AT90	Original instruction set from 1995.
AVRe	megaAVR®	Multiply (xMULxx), Move Word (MOVW), and enhanced Load Program Memory (LPM) added to the AVR instruction set. No timing differences.
AVRe	tinyAVR®	Multiply not included, but else equal to AVRe for megaAVR.
AVRxm	XMEGA®	Significantly different timing compared to AVR(e). The Read Modify Write (RMW) and DES encryption instructions are unique to this version.
AVRxt	(AVR)	AVR 2016 and onwards. This variant is based on AVRe and AVRxm. Closer related to AVRe, but with improved timing.
AVRrc	tinyAVR	The Reduced Core AVR CPU was developed for ultra-low pinout (6-pin) size constrained devices. The AVRrc therefore only has a 16 registers register-file (R31-R16) and a limited instruction set.

Table 4-2. Arithmetic and Logic Instructions

Mnemonic	Operands	Description		Op		Flags	#Clocks AVR	#Clocks AVRxm	#Clocks AVRxt	#Clocks AVRrc
ADD	Rd, Rr	Add without Carry	Rd	←	$Rd + Rr$	Z,C,N,V,S,H	1	1	1	1
ADC	Rd, Rr	Add with Carry	Rd	←	$Rd + Rr + C$	Z,C,N,V,S,H	1	1	1	1
ADIW	Rd, K	Add Immediate to Word	Rd	←	$Rd + 1:Rd + K$	Z,C,N,V,S	2	2	2	N/A
SUB	Rd, Rr	Subtract without Carry	Rd	←	$Rd - Rr$	Z,C,N,V,S,H	1	1	1	1
SUBI	Rd, K	Subtract Immediate	Rd	←	$Rd - K$	Z,C,N,V,S,H	1	1	1	1
SBC	Rd, Rr	Subtract with Carry	Rd	←	$Rd - Rr - C$	Z,C,N,V,S,H	1	1	1	1
SBCI	Rd, K	Subtract Immediate with Carry	Rd	←	$Rd - K - C$	Z,C,N,V,S,H	1	1	1	1
SBIW	Rd, K	Subtract Immediate from Word	$Rd + 1:Rd$	←	$Rd + 1:Rd - K$	Z,C,N,V,S	2	2	2	N/A
AND	Rd, Rr	Logical AND	Rd	←	$Rd \cdot Rr$	Z,N,V,S	1	1	1	1

Mnemonic	Operands	Description		Op		Flags	#Clocks AVR	#Clocks AVRxm	#Clocks AVRxt	#Clocks AVRrc
ANDI	Rd, K	Logical AND with Immediate	Rd	←	Rd • K	Z,N,V,S	1	1	1	1
OR	Rd, Rr	Logical OR	Rd	←	Rd v Rr	Z,N,V,S	1	1	1	1
ORI	Rd, K	Logical OR with Immediate	Rd	←	Rd v K	Z,N,V,S	1	1	1	1
EOR	Rd, Rr	Exclusive OR	Rd	←	Rd ⊕ Rr	Z,N,V,S	1	1	1	1
COM	Rd	One's Complement	Rd	←	\$FF - Rd	Z,C,N,V,S	1	1	1	1
NEG	Rd	Two's Complement	Rd	←	\$00 - Rd	Z,C,N,V,S,H	1	1	1	1
SBR	Rd,K	Set Bit(s) in Register	Rd	←	Rd v K	Z,N,V,S	1	1	1	1
CBR	Rd,K	Clear Bit(s) in Register	Rd	←	Rd • (\$FFh - K)	Z,N,V,S	1	1	1	1
INC	Rd	Increment	Rd	←	Rd + 1	Z,N,V,S	1	1	1	1
DEC	Rd	Decrement	Rd	←	Rd - 1	Z,N,V,S	1	1	1	1
TST	Rd	Test for Zero or Minus	Rd	←	Rd • Rd	Z,N,V,S	1	1	1	1
CLR	Rd	Clear Register	Rd	←	Rd ⊕ Rd	Z,N,V,S	1	1	1	1
SER	Rd	Set Register	Rd	←	\$FF	None	1	1	1	1
MUL	Rd,Rr	Multiply Unsigned	R1:R0	←	Rd x Rr (UU)	Z,C	2	2	2	N/A
MULS	Rd,Rr	Multiply Signed	R1:R0	←	Rd x Rr (SS)	Z,C	2	2	2	N/A
MULSU	Rd,Rr	Multiply Signed with Unsigned	R1:R0	←	Rd x Rr (SU)	Z,C	2	2	2	N/A
FMUL	Rd,Rr	Fractional Multiply Unsigned	R1:R0	←	Rd x Rr<<1 (UU)	Z,C	2	2	2	N/A
FMULS	Rd,Rr	Fractional Multiply Signed	R1:R0	←	Rd x Rr<<1 (SS)	Z,C	2	2	2	N/A
FMULSU	Rd,Rr	Fractional Multiply Signed with Unsigned	R1:R0	←	Rd x Rr<<1 (SU)	Z,C	2	2	2	N/A
DES	K	Data Encryption	if (H = 0) then R15:R0 else if (H = 1) then R15:R0	← ←	Encrypt(R15:R0, K) Decrypt(R15:R0, K)		N/A	1/2	N/A	N/A

Table 4-3. Branch Instructions

Mnemonic	Operands	Description		Op		Flags	#Clocks AVR	#Clocks AVRxm	#Clocks AVRxt	#Clocks AVRrc
RJMP	k	Relative Jump	PC	←	PC + k + 1	None	2	2	2	2
IJMP		Indirect Jump to (Z)	PC(15:0) PC(21:16)	← ←	Z 0	None	2	2	2	2

Mnemonic	Operands	Description		Op		Flags	#Clocks AVR	#Clocks AVRxm	#Clocks AVRxt	#Clocks AVRrc
EIJMP		Extended Indirect Jump to (Z)	PC(15:0) PC(21:16)	← ←	Z EIND	None	2	2	2	N/A
JMP	k	Jump	PC	←	k	None	3	3	3	N/A
RCALL	k	Relative Call Subroutine	PC	←	PC + k + 1	None	3 / 4 ⁽¹⁾	2 / 3 ⁽¹⁾	2 / 3	3 ⁽¹⁾
ICALL		Indirect Call to (Z)	PC(15:0) PC(21:16)	← ←	Z 0	None	3 / 4 ⁽¹⁾	2 / 3 ⁽¹⁾	2 / 3	3 ⁽¹⁾
EICALL		Extended Indirect Call to (Z)	PC(15:0) PC(21:16)	← ←	Z EIND	None	4 ⁽¹⁾	3 ⁽¹⁾	2 / 3	N/A
CALL	k	Call Subroutine	PC	←	k	None	4 / 5 ⁽¹⁾	3 / 4 ⁽¹⁾	3 / 4	N/A
RET		Subroutine Return	PC	←	STACK	None	4 / 5 ⁽¹⁾	4 / 5 ⁽¹⁾	4 / 5	6 ⁽¹⁾
RETI		Interrupt Return	PC	←	STACK	I	4 / 5 ⁽¹⁾	4 / 5 ⁽¹⁾	4 / 5	6 ⁽¹⁾
CPSE	Rd,Rr	Compare, skip if Equal	if (Rd = Rr) PC	←	PC + 2 or 3	None	1 / 2 / 3	1 / 2 / 3	1 / 2 / 3	1 / 2
CP	Rd,Rr	Compare	Rd - Rr			Z,C,N,V,S,H	1	1	1	1
CPC	Rd,Rr	Compare with Carry	Rd - Rr - C			Z,C,N,V,S,H	1	1	1	1
CPI	Rd,K	Compare with Immediate	Rd - K			Z,C,N,V,S,H	1	1	1	1
SBRC	Rr, b	Skip if Bit in Register Cleared	if (Rr(b) = 0) PC	←	PC + 2 or 3	None	1 / 2 / 3	1 / 2 / 3	1 / 2 / 3	1 / 2
SBRS	Rr, b	Skip if Bit in Register Set	if (Rr(b) = 1) PC	←	PC + 2 or 3	None	1 / 2 / 3	1 / 2 / 3	1 / 2 / 3	1 / 2
SBIC	A, b	Skip if Bit in I/O Register Cleared	if (I/O(A,b) = 0) PC	←	PC + 2 or 3	None	1 / 2 / 3	2 / 3 / 4	1 / 2 / 3	1 / 2
SBIS	A, b	Skip if Bit in I/O Register Set	If (I/O(A,b) = 1) PC	←	PC + 2 or 3	None	1 / 2 / 3	2 / 3 / 4	1 / 2 / 3	1 / 2
BRBS	s, k	Branch if Status Flag Set	if (SREG(s) = 1) then PC	←	PC + k + 1	None	1 / 2	1 / 2	1 / 2	1 / 2
BRBC	s, k	Branch if Status Flag Cleared	if (SREG(s) = 0) then PC	←	PC + k + 1	None	1 / 2	1 / 2	1 / 2	1 / 2
BREQ	k	Branch if Equal	if (Z = 1) then PC	←	PC + k + 1	None	1 / 2	1 / 2	1 / 2	1 / 2
BRNE	k	Branch if Not Equal	if (Z = 0) then PC	←	PC + k + 1	None	1 / 2	1 / 2	1 / 2	1 / 2
BRCS	k	Branch if Carry Set	if (C = 1) then PC	←	PC + k + 1	None	1 / 2	1 / 2	1 / 2	1 / 2
BRCC	k	Branch if Carry Cleared	if (C = 0) then PC	←	PC + k + 1	None	1 / 2	1 / 2	1 / 2	1 / 2
BRSH	k	Branch if Same or Higher	if (C = 0) then PC	←	PC + k + 1	None	1 / 2	1 / 2	1 / 2	1 / 2

Mnemonic	Operands	Description		Op		Flags	#Clocks AVR	#Clocks AVRxm	#Clocks AVRxt	#Clocks AVRrc
BRLO	k	Branch if Lower	if (C = 1) then PC	←	PC + k + 1	None	1 / 2	1 / 2	1 / 2	1 / 2
BRMI	k	Branch if Minus	if (N = 1) then PC	←	PC + k + 1	None	1 / 2	1 / 2	1 / 2	1 / 2
BRPL	k	Branch if Plus	if (N = 0) then PC	←	PC + k + 1	None	1 / 2	1 / 2	1 / 2	1 / 2
BRGE	k	Branch if Greater or Equal, Signed	if (N ⊕ V = 0) then PC	←	PC + k + 1	None	1 / 2	1 / 2	1 / 2	1 / 2
BRLT	k	Branch if Less Than, Signed	if (N ⊕ V = 1) then PC	←	PC + k + 1	None	1 / 2	1 / 2	1 / 2	1 / 2
BRHS	k	Branch if Half Carry Flag Set	if (H = 1) then PC	←	PC + k + 1	None	1 / 2	1 / 2	1 / 2	1 / 2
BRHC	k	Branch if Half Carry Flag Cleared	if (H = 0) then PC	←	PC + k + 1	None	1 / 2	1 / 2	1 / 2	1 / 2
BRTS	k	Branch if T Flag Set	if (T = 1) then PC	←	PC + k + 1	None	1 / 2	1 / 2	1 / 2	1 / 2
BRTC	k	Branch if T Flag Cleared	if (T = 0) then PC	←	PC + k + 1	None	1 / 2	1 / 2	1 / 2	1 / 2
BRVS	k	Branch if Overflow Flag is Set	if (V = 1) then PC	←	PC + k + 1	None	1 / 2	1 / 2	1 / 2	1 / 2
BRVC	k	Branch if Overflow Flag is Cleared	if (V = 0) then PC	←	PC + k + 1	None	1 / 2	1 / 2	1 / 2	1 / 2
BRIE	k	Branch if Interrupt Enabled	if (I = 1) then PC	←	PC + k + 1	None	1 / 2	1 / 2	1 / 2	1 / 2
BRID	k	Branch if Interrupt Disabled	if (I = 0) then PC	←	PC + k + 1	None	1 / 2	1 / 2	1 / 2	1 / 2

Table 4-4. Data Transfer Instructions

Mnemonic	Operands	Description		Op		Flags	#Clocks AVR	#Clocks AVRxm	#Clocks AVRxt	#Clocks AVRrc
MOV	Rd, Rr	Copy Register	Rd	←	Rr	None	1	1	1	1
MOVW	Rd, Rr	Copy Register Pair	Rd+1:Rd	←	Rr+1:Rr	None	1	1	1	N/A
LDI	Rd, K	Load Immediate	Rd	←	K	None	1	1	1	1
LDS	Rd, k	Load Direct from data space	Rd	←	(k)	None	2 ⁽¹⁾	2 ⁽¹⁾	3 ⁽¹⁾	2
LD	Rd, X	Load Indirect	Rd	←	(X)	None	2 ⁽¹⁾	1 ⁽¹⁾	2 ⁽¹⁾	1 / 2
LD	Rd, X+	Load Indirect and Post-Increment	Rd X	← ←	(X) X + 1	None	2 ⁽¹⁾	1 ⁽¹⁾	2 ⁽¹⁾	2 / 3
LD	Rd, -X	Load Indirect and Pre-Decrement	X Rd	← ←	X - 1 (X)	None	2 ⁽¹⁾	2 ⁽¹⁾	2 ⁽¹⁾	2 / 3
LD	Rd, Y	Load Indirect	Rd	←	(Y)	None	2 ⁽¹⁾	1 ⁽¹⁾	2 ⁽¹⁾	1 / 2

Mnemonic	Operands	Description		Op		Flags	#Clocks AVR	#Clocks AVRxm	#Clocks AVRxt	#Clocks AVRrc
LD	Rd, Y+	Load Indirect and Post-Increment	Rd Y	← ←	(Y) Y + 1	None	2 ⁽¹⁾	1 ⁽¹⁾	2 ⁽¹⁾	2 / 3
LD	Rd, -Y	Load Indirect and Pre-Decrement	Y Rd	← ←	Y - 1 (Y)	None	2 ⁽¹⁾	2 ⁽¹⁾	2 ⁽¹⁾	2 / 3
LDD	Rd, Y+q	Load Indirect with Displacement	Rd	←	(Y + q)	None	2 ⁽¹⁾	2 ⁽¹⁾	2 ⁽¹⁾	N/A
LD	Rd, Z	Load Indirect	Rd	←	(Z)	None	2 ⁽¹⁾	1 ⁽¹⁾	2 ⁽¹⁾	1 / 2
LD	Rd, Z+	Load Indirect and Post-Increment	Rd Z	← ←	(Z) Z+1	None	2 ⁽¹⁾	1 ⁽¹⁾	2 ⁽¹⁾	2 / 3
LD	Rd, -Z	Load Indirect and Pre-Decrement	Z Rd	← ←	Z - 1 (Z)	None	2 ⁽¹⁾	2 ⁽¹⁾	2 ⁽¹⁾	2 / 3
LDD	Rd, Z+q	Load Indirect with Displacement	Rd	←	(Z + q)	None	2 ⁽¹⁾	2 ⁽¹⁾	2 ⁽¹⁾	N/A
STS	k, Rr	Store Direct to Data Space	(k)	←	Rd	None	2 ⁽¹⁾⁽²⁾	2 ⁽¹⁾⁽²⁾	2 ⁽¹⁾⁽²⁾	1
ST	X, Rr	Store Indirect	(X)	←	Rr	None	1 ⁽¹⁾⁽²⁾	1 ⁽¹⁾⁽²⁾	1 ⁽¹⁾⁽²⁾	1
ST	X+, Rr	Store Indirect and Post-Increment	(X) X	← ←	Rr X + 1	None	1 ⁽¹⁾⁽²⁾	1 ⁽¹⁾⁽²⁾	1 ⁽¹⁾⁽²⁾	1
ST	-X, Rr	Store Indirect and Pre-Decrement	X (X)	← ←	X - 1 Rr	None	2 ⁽¹⁾⁽²⁾	2 ⁽¹⁾⁽²⁾	1 ⁽¹⁾⁽²⁾	2
ST	Y, Rr	Store Indirect	(Y)	←	Rr	None	2 ⁽¹⁾⁽²⁾	1 ⁽¹⁾⁽²⁾	1 ⁽¹⁾⁽²⁾	1
ST	Y+, Rr	Store Indirect and Post-Increment	(Y) Y	← ←	Rr Y + 1	None	2 ⁽¹⁾⁽²⁾	1 ⁽¹⁾⁽²⁾	1 ⁽¹⁾⁽²⁾	1
ST	-Y, Rr	Store Indirect and Pre-Decrement	Y (Y)	← ←	Y - 1 Rr	None	2 ⁽¹⁾⁽²⁾	2 ⁽¹⁾⁽²⁾	1 ⁽¹⁾⁽²⁾	2
STD	Y+q, Rr	Store Indirect with Displacement	(Y + q)	←	Rr	None	2 ⁽¹⁾⁽²⁾	2 ⁽¹⁾⁽²⁾	1 ⁽¹⁾⁽²⁾	N/A
ST	Z, Rr	Store Indirect	(Z)	←	Rr	None	2 ⁽¹⁾⁽²⁾	1 ⁽¹⁾⁽²⁾	1 ⁽¹⁾⁽²⁾	1
ST	Z+, Rr	Store Indirect and Post-Increment	(Z) Z	← ←	Rr Z + 1	None	2 ⁽¹⁾⁽²⁾	1 ⁽¹⁾⁽²⁾	1 ⁽¹⁾⁽²⁾	1
ST	-Z, Rr	Store Indirect and Pre-Decrement	Z	←	Z - 1	None	2 ⁽¹⁾⁽²⁾	2 ⁽¹⁾⁽²⁾	1 ⁽¹⁾⁽²⁾	2
STD	Z+q, Rr	Store Indirect with Displacement	(Z + q)	←	Rr	None	2 ⁽¹⁾⁽²⁾	2 ⁽¹⁾⁽²⁾	1 ⁽¹⁾⁽²⁾	N/A
LPM		Load Program Memory	R0	←	(Z)	None	3	3	3	N/A
LPM	Rd, Z	Load Program Memory	Rd	←	(Z)	None	3	3	3	N/A

Mnemonic	Operands	Description		Op		Flags	#Clocks AVR	#Clocks AVRxm	#Clocks AVRxt	#Clocks AVRrc
LPM	Rd, Z+	Load Program Memory and Post-Increment	Rd Z	← ←	(Z) Z + 1	None	3	3	3	N/A
ELPM		Extended Load Program Memory	R0	←	(RAMPZ:Z)	None	3	3	3	N/A
ELPM	Rd, Z	Extended Load Program Memory	Rd	←	(RAMPZ:Z)	None	3	3	3	N/A
ELPM	Rd, Z+	Extended Load Program Memory and Post-Increment	Rd (RAMPZ:Z)	← ←	(RAMPZ:Z) (RAMPZ:Z) + 1	None	3	3	3	N/A
SPM		Store Program Memory	(RAMPZ:Z)	←	R1:R0	None	(4)	(4)	4(3)	N/A
SPM	Z+	Store Program Memory and Post-Increment by 2	(RAMPZ:Z) Z	← ←	R1:R0 Z + 2	None	(4)	(4)	4(3)	N/A
IN	Rd, A	In From I/O Location	Rd	←	I/O(A)	None	1	1	1	1
OUT	A, Rr	Out To I/O Location	I/O(A)	←	Rr	None	1	1	1	1
PUSH	Rr	Push Register on Stack	STACK	←	Rr	None	2	1(1)	1	1(1)
POP	Rd	Pop Register from Stack	Rd	←	STACK	None	2	2(1)	2	3(1)
XCH	Z, Rd	Exchange	(Z) Rd	← ←	Rd (Z)	None	N/A	1	N/A	N/A
LAS	Z, Rd	Load and Set	(Z) Rd	← ←	Rd v (Z) (Z)	None	N/A	1	N/A	N/A
LAC	Z, Rd	Load and Clear	(Z) Rd	← ←	(\$FF – Rd) • (Z) (Z)	None	N/A	1	N/A	N/A
LAT	Z, Rd	Load and Toggle	(Z) Rd	← ←	Rd ⊕ (Z) (Z)	None	N/A	1	N/A	N/A

Table 4-5. Bit and Bit-test Instructions

Mnemonic	Operands	Description		Op		Flags	#Clocks AVR	#Clocks AVRxm	#Clocks AVRxt	#Clocks AVRrc
LSL	Rd	Logical Shift Left	Rd(n+1) Rd(0) C	← ← ←	Rd(n) 0 Rd(7)	Z,C,N,V,H	1	1	1	1
LSR	Rd	Logical Shift Right	Rd(n) Rd(7) C	← ← ←	Rd(n+1) 0 Rd(0)	Z,C,N,V	1	1	1	1

Mnemonic	Operands	Description		Op		Flags	#Clocks AVR	#Clocks AVRxm	#Clocks AVRxt	#Clocks AVRrc
ROL	Rd	Rotate Left Through Carry	Rd(0) Rd(n+1) C	← ← ←	C Rd(n) Rd(7)	Z,C,N,V,H	1	1	1	1
ROR	Rd	Rotate Right Through Carry	Rd(7) Rd(n) C	← ← ←	C Rd(n+1) Rd(0)	Z,C,N,V	1	1	1	1
ASR	Rd	Arithmetic Shift Right	Rd(n)	←	Rd(n+1), n=0..6	Z,C,N,V	1	1	1	1
SWAP	Rd	Swap Nibbles	Rd(3..0)	↔	Rd(7..4)	None	1	1	1	1
SBI	A, b	Set Bit in I/O Register	I/O(A, b)	←	1	None	2	1	1	1
CBI	A, b	Clear Bit in I/O Register	I/O(A, b)	←	0	None	2	1	1	1
BST	Rr, b	Bit Store from Register to T	T	←	Rr(b)	T	1	1	1	1
BLD	Rd, b	Bit load from T to Register	Rd(b)	←	T	None	1	1	1	1
BSET	s	Flag Set	SREG(s)	←	1	SREG(s)	1	1	1	1
BCLR	s	Flag Clear	SREG(s)	←	0	SREG(s)	1	1	1	1
SEC		Set Carry	C	←	1	C	1	1	1	1
CLC		Clear Carry	C	←	0	C	1	1	1	1
SEN		Set Negative Flag	N	←	1	N	1	1	1	1
CLN		Clear Negative Flag	N	←	0	N	1	1	1	1
SEZ		Set Zero Flag	Z	←	1	Z	1	1	1	1
CLZ		Clear Zero Flag	Z	←	0	Z	1	1	1	1
SEI		Global Interrupt Enable	I	←	1	I	1	1	1	1
CLI		Global Interrupt Disable	I	←	0	I	1	1	1	1
SES		Set Signed Test Flag	S	←	1	S	1	1	1	1
CLS		Clear Signed Test Flag	S	←	0	S	1	1	1	1
SEV		Set Two's Complement Overflow	V	←	1	V	1	1	1	1
CLV		Clear Two's Complement Overflow	V	←	0	V	1	1	1	1
SET		Set T in SREG	T	←	1	T	1	1	1	1
CLT		Clear T in SREG	T	←	0	T	1	1	1	1

Mnemonic	Operands	Description		Op		Flags	#Clocks AVR	#Clocks AVRxm	#Clocks AVRxt	#Clocks AVRrc
SEH		Set Half Carry Flag in SREG		H ←	1	H	1	1	1	1
CLH		Clear Half Carry Flag in SREG		H ←	0	H	1	1	1	1

Table 4-6. MCU Control Instructions

Mnemonic	Operands	Description	Operation	Flags	#Clocks AVR	#Clocks AVRxm	#Clocks AVRxt	#Clocks AVRrc
BREAK		Break	(See also in Debug interface description)	None	1	1	1	1
NOP		No Operation		None	1	1	1	1
SLEEP		Sleep	(see also power management and sleep description)	None	1	1	1	1
WDR		Watchdog Reset	(see also Watchdog Controller description)	None	1	1	1	1

Note:

1. Cycle time for data memory accesses assume internal RAM access, and are not valid for accesses through the NVM controller. A minimum of one extra cycle must be added when accessing memory through the NVM controller (such as Flash and EEPROM), but depending on simultaneous accesses by other masters or the NVM controller state, there may be more than one extra cycle.
2. One extra cycle must be added when accessing lower (64 bytes of) I/O space.
3. The instruction is not available on all devices.
4. Device dependent. See the device specific datasheet.

5. ADC – Add with Carry

5.1. Description

Adds two registers and the contents of the C Flag and places the result in the destination register Rd.

Operation:

$$(i) \quad R_d \leftarrow R_d + R_r + C$$

Syntax:

$$(i) \quad \text{ADC } R_d, R_r$$

Operands:

$$0 \leq d \leq 31, 0 \leq r \leq 31$$

Program Counter:

$$PC \leftarrow PC + 1$$

16-bit Opcode:

0001	11rd	dddd	rrrr
------	------	------	------

5.2. Status Register (SREG) and Boolean Formula

I	T	H	S	V	N	Z	C
–	–	↔	↔	↔	↔	↔	↔

$$\mathbf{H} \quad R_{d3} \cdot R_{r3} + R_{r3} \cdot \overline{R_{d3}} + \overline{R_{d3}} \cdot R_{d3}$$

Set if there was a carry from bit 3; cleared otherwise.

$$\mathbf{S} \quad N \oplus V, \text{ for signed tests.}$$

$$\mathbf{V} \quad R_{d7} \cdot R_{r7} \cdot \overline{R_7} + \overline{R_{d7}} \cdot \overline{R_{r7}} \cdot R_7$$

Set if two's complement overflow resulted from the operation; cleared otherwise.

$$\mathbf{N} \quad R_7$$

Set if MSB of the result is set; cleared otherwise.

$$\mathbf{Z} \quad \overline{R_7} \cdot \overline{R_6} \cdot \overline{R_5} \cdot \overline{R_4} \cdot \overline{R_3} \cdot \overline{R_2} \cdot \overline{R_1} \cdot \overline{R_0}$$

Set if the result is \$00; cleared otherwise.

$$\mathbf{C} \quad R_{d7} \cdot R_{r7} + R_{r7} \cdot \overline{R_{d7}} + \overline{R_{d7}} \cdot R_{d7}$$

Set if there was carry from the MSB of the result; cleared otherwise.

R (Result) equals Rd after the operation.

Example:

```

add r2,r0    ; Add R1:R0 to R3:R2
add r2,r0    ; Add low byte
adc r3,r1    ; Add with carry high byte
    
```

Words

1 (2 bytes)

Cycles

1

6. ADD – Add without Carry

6.1. Description

Adds two registers without the C Flag and places the result in the destination register Rd.

Operation:

- (i) $Rd \leftarrow Rd + Rr$

Syntax:

- (i) ADD Rd,Rr

Operands:

$0 \leq d \leq 31, 0 \leq r \leq 31$

Program Counter:

$PC \leftarrow PC + 1$

16-bit Opcode:

0000	11rd	dddd	rrrr
------	------	------	------

6.2. Status Register (SREG) and Boolean Formula

I	T	H	S	V	N	Z	C
–	–	\Leftrightarrow	\Leftrightarrow	\Leftrightarrow	\Leftrightarrow	\Leftrightarrow	\Leftrightarrow

H $Rd3 \cdot Rr3 + Rr3 \cdot \overline{Rd3} + \overline{Rd3} \cdot Rr3$

Set if there was a carry from bit 3; cleared otherwise.

S $N \oplus V$, for signed tests.

V $Rd7 \cdot Rr7 \cdot \overline{R7} + \overline{Rd7} \cdot \overline{Rr7} \cdot R7$

Set if two's complement overflow resulted from the operation; cleared otherwise.

N R7

Set if MSB of the result is set; cleared otherwise.

Z $\overline{R7} \cdot \overline{R6} \cdot \overline{R5} \cdot \overline{R4} \cdot \overline{R3} \cdot \overline{R2} \cdot \overline{R1} \cdot \overline{R0}$

Set if the result is \$00; cleared otherwise.

C $Rd7 \cdot Rr7 + Rr7 \cdot \overline{Rd7} + \overline{Rd7} \cdot Rr7$

Set if there was carry from the MSB of the result; cleared otherwise.

R (Result) equals Rd after the operation.

Example:

```
add r1,r2 ; Add r2 to r1 (r1=r1+r2)
add r28,r28 ; Add r28 to itself (r28=r28+r28)
```

Words 1 (2 bytes)

Cycles 1

7. ADIW – Add Immediate to Word

7.1. Description

Adds an immediate value (0 - 63) to a register pair and places the result in the register pair. This instruction operates on the upper four register pairs, and is well suited for operations on the pointer registers.

This instruction is not available in all devices. Refer to the device specific instruction set summary.

Operation:

$$(i) \quad R_{d+1}:R_d \leftarrow R_{d+1}:R_d + K$$

Syntax:

Operands:

Program Counter:

$$(i) \quad \text{ADIW } R_{d+1}:R_d, K \quad d \in \{24,26,28,30\}, 0 \leq K \leq 63 \quad PC \leftarrow PC + 1$$

16-bit Opcode:

1001	0110	KKdd	KKKK
------	------	------	------

7.2. Status Register (SREG) and Boolean Formula

I	T	H	S	V	N	Z	C
–	–	–	↔	↔	↔	↔	↔

S $N \oplus V$, for signed tests.

V $\overline{R_{dh7}} \cdot R_{15}$

Set if two's complement overflow resulted from the operation; cleared otherwise.

N R_{15}

Set if MSB of the result is set; cleared otherwise.

Z $\overline{R_{15}} \cdot \overline{R_{14}} \cdot \overline{R_{13}} \cdot \overline{R_{12}} \cdot \overline{R_{11}} \cdot \overline{R_{10}} \cdot \overline{R_9} \cdot \overline{R_8} \cdot \overline{R_7} \cdot \overline{R_6} \cdot \overline{R_5} \cdot \overline{R_4} \cdot \overline{R_3} \cdot \overline{R_2} \cdot \overline{R_1} \cdot \overline{R_0}$

Set if the result is \$0000; cleared otherwise.

C $\overline{R_{15}} \cdot R_{dh7}$

Set if there was carry from the MSB of the result; cleared otherwise.

R (Result) equals $R_{dh}:R_{dl}$ after the operation ($R_{dh7}-R_{dh0} = R_{15}-R_8$, $R_{dl7}-R_{dl0} = R_7-R_0$).

Example:

```
adiw r25:24,1 ; Add 1 to r25:r24
adiw ZH:ZL,63 ; Add 63 to the Z-pointer(r31:r30)
```

Words

1 (2 bytes)

Cycles

1

8. AND – Logical AND

8.1. Description

Performs the logical AND between the contents of register Rd and register Rr, and places the result in the destination register Rd.

Operation:

$$(i) \quad R_d \leftarrow R_d \cdot R_r$$

Syntax:

Operands:

Program Counter:

$$(i) \quad \text{AND } R_d, R_r$$

$$0 \leq d \leq 31, 0 \leq r \leq 31$$

$$PC \leftarrow PC + 1$$

16-bit Opcode:

0010	00rd	dddd	rrrr
------	------	------	------

8.2. Status Register (SREG) and Boolean Formula

I	T	H	S	V	N	Z	C
–	–	–	↔	0	↔	↔	–

S $N \oplus V$, for signed tests.

V 0

Cleared.

N R7

Set if MSB of the result is set; cleared otherwise.

Z $\overline{R_7} \cdot \overline{R_6} \cdot \overline{R_5} \cdot \overline{R_4} \cdot \overline{R_3} \cdot \overline{R_2} \cdot \overline{R_1} \cdot \overline{R_0}$

Set if the result is \$00; cleared otherwise.

R (Result) equals Rd after the operation.

Example:

```
and r2,r3 ; Bitwise and r2 and r3, result in r2
ldi r16,1 ; Set bitmask 0000 0001 in r16
and r2,r16 ; Isolate bit 0 in r2
```

Words 1 (2 bytes)

Cycles 1

9. ANDI – Logical AND with Immediate

9.1. Description

Performs the logical AND between the contents of register Rd and a constant, and places the result in the destination register Rd.

Operation:

$$(i) \quad R_d \leftarrow R_d \cdot K$$

Syntax:

Operands:

Program Counter:

$$(i) \quad \text{ANDI } R_d, K$$

$$16 \leq d \leq 31, 0 \leq K \leq 255$$

$$PC \leftarrow PC + 1$$

16-bit Opcode:

0111	KKKK	dddd	KKKK
------	------	------	------

9.2. Status Register (SREG) and Boolean Formula

I	T	H	S	V	N	Z	C
–	–	–	↔	0	↔	↔	–

S $N \oplus V$, for signed tests.

V 0

Cleared.

N R7

Set if MSB of the result is set; cleared otherwise.

Z $\overline{R7} \cdot \overline{R6} \cdot \overline{R5} \cdot \overline{R4} \cdot \overline{R3} \cdot \overline{R2} \cdot \overline{R1} \cdot \overline{R0}$

Set if the result is \$00; cleared otherwise.

R (Result) equals Rd after the operation.

Example:

```
andi r17,$0F ; Clear upper nibble of r17
andi r18,$10 ; Isolate bit 4 in r18
andi r19,$AA ; Clear odd bits of r19
```

Words 1 (2 bytes)

Cycles 1

10. ASR – Arithmetic Shift Right

10.1. Description

Shifts all bits in Rd one place to the right. Bit 7 is held constant. Bit 0 is loaded into the C Flag of the SREG. This operation effectively divides a signed value by two without changing its sign. The Carry Flag can be used to round the result.

Operation:

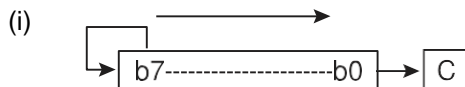

Syntax:

Operands:

Program Counter:

(i) ASR Rd

$0 \leq d \leq 31$

$PC \leftarrow PC + 1$

16-bit Opcode:

1001	010d	dddd	0101
------	------	------	------

10.2. Status Register (SREG) and Boolean Formula

I	T	H	S	V	N	Z	C
–	–	–	↔	↔	↔	↔	↔

S $N \oplus V$, for signed tests.

V $N \oplus C$, for N and C after the shift.

N R7

Set if MSB of the result is set; cleared otherwise.

Z $\overline{R7} \cdot \overline{R6} \cdot \overline{R5} \cdot \overline{R4} \cdot \overline{R3} \cdot \overline{R2} \cdot \overline{R1} \cdot \overline{R0}$

Set if the result is \$00; cleared otherwise.

C Rd0

Set if, before the shift, the LSB of Rd was set; cleared otherwise.

R (Result) equals Rd after the operation.

Example:

```
ldi r16,$10 ; Load decimal 16 into r16
asr r16 ; r16=r16 / 2
ldi r17,$FC ; Load -4 in r17
asr r17 ; r17=r17/2
```

Words

1 (2 bytes)

Cycles

1

11. BCLR – Bit Clear in SREG

11.1. Description

Clears a single Flag in SREG.

Operation:

- (i) $SREG(s) \leftarrow 0$

Syntax:

Operands:

Program Counter:

- (i) BCLR s

$0 \leq s \leq 7$

$PC \leftarrow PC + 1$

16-bit Opcode:

1001	0100	1sss	1000
------	------	------	------

11.2. Status Register (SREG) and Boolean Formula

I	T	H	S	V	N	Z	C
\Leftrightarrow	\Leftrightarrow	\Leftrightarrow	\Leftrightarrow	\Leftrightarrow	\Leftrightarrow	\Leftrightarrow	\Leftrightarrow

I 0 if s = 7; Unchanged otherwise.

T 0 if s = 6; Unchanged otherwise.

H 0 if s = 5; Unchanged otherwise.

S 0 if s = 4; Unchanged otherwise.

V 0 if s = 3; Unchanged otherwise.

N 0 if s = 2; Unchanged otherwise.

Z 0 if s = 1; Unchanged otherwise.

C 0 if s = 0; Unchanged otherwise.

Example:

```
bclr 0 ; Clear Carry Flag
bclr 7 ; Disable interrupts
```

Words 1 (2 bytes)

Cycles 1

12. BLD – Bit Load from the T Flag in SREG to a Bit in Register

12.1. Description

Copies the T Flag in the SREG (Status Register) to bit b in register Rd.

Operation:

(i) $Rd(b) \leftarrow T$

Syntax:

(i) BLD Rd,b

Operands:

$0 \leq d \leq 31, 0 \leq b \leq 7$

Program Counter:

$PC \leftarrow PC + 1$

16 bit Opcode:

1111	100d	dddd	0bbb
------	------	------	------

12.2. Status Register (SREG) and Boolean Formula

I	T	H	S	V	N	Z	C
–	–	–	–	–	–	–	–

Example:

```
        ; Copy bit  
bst r1,2 ; Store bit 2 of r1 in T Flag  
bld r0,4 ; Load T Flag into bit 4 of r0
```

Words 1 (2 bytes)

Cycles 1

13. BRBC – Branch if Bit in SREG is Cleared

13.1. Description

Conditional relative branch. Tests a single bit in SREG and branches relatively to PC if the bit is cleared. This instruction branches relatively to PC in either direction ($PC - 63 \leq \text{destination} \leq PC + 64$). Parameter k is the offset from PC and is represented in two's complement form.

Operation:

- (i) If $SREG(s) = 0$ then $PC \leftarrow PC + k + 1$, else $PC \leftarrow PC + 1$

Syntax:

Operands:

Program Counter:

- (i) BRBC s,k

$0 \leq s \leq 7, -64 \leq k \leq +63$

$PC \leftarrow PC + k + 1$

$PC \leftarrow PC + 1$, if condition is false

16-bit Opcode:

1111	01kk	kkkk	ksss
------	------	------	------

13.2. Status Register (SREG) and Boolean Formula

I	T	H	S	V	N	Z	C
–	–	–	–	–	–	–	–

Example:

```
cpu r20,5 ; Compare r20 to the value 5
brbc 1,noteq ; Branch if Zero Flag cleared
...
noteq: nop ; Branch destination (do nothing)
```

Words	1 (2 bytes)
Cycles	1 if condition is false 2 if condition is true

14. BRBS – Branch if Bit in SREG is Set

14.1. Description

Conditional relative branch. Tests a single bit in SREG and branches relatively to PC if the bit is set. This instruction branches relatively to PC in either direction ($PC - 63 \leq \text{destination} \leq PC + 64$). Parameter k is the offset from PC and is represented in two's complement form.

Operation:

- (i) If $SREG(s) = 1$ then $PC \leftarrow PC + k + 1$, else $PC \leftarrow PC + 1$

Syntax:

Operands:

Program Counter:

- (i) BRBS s,k

$0 \leq s \leq 7, -64 \leq k \leq +63$

$PC \leftarrow PC + k + 1$

$PC \leftarrow PC + 1$, if condition is false

16-bit Opcode:

1111	00kk	kkkk	ksss
------	------	------	------

14.2. Status Register (SREG) and Boolean Formula

I	T	H	S	V	N	Z	C
–	–	–	–	–	–	–	–

Example:

```
bst r0,3 ; Load T bit with bit 3 of r0
brbs 6,bitset ; Branch T bit was set
...
bitset: nop ; Branch destination (do nothing)
```

Words	1 (2 bytes)
Cycles	1 if condition is false 2 if condition is true

15. BRCC – Branch if Carry Cleared

15.1. Description

Conditional relative branch. Tests the Carry Flag (C) and branches relatively to PC if C is cleared. This instruction branches relatively to PC in either direction ($PC - 63 \leq \text{destination} \leq PC + 64$). Parameter k is the offset from PC and is represented in two's complement form. (Equivalent to instruction BRBC 0,k.)

Operation:

- (i) If $C = 0$ then $PC \leftarrow PC + k + 1$, else $PC \leftarrow PC + 1$

Syntax:

Operands:

Program Counter:

- (i) BRCC k

$-64 \leq k \leq +63$

$PC \leftarrow PC + k + 1$

$PC \leftarrow PC + 1$, if condition is false

16-bit Opcode:

1111	01kk	kkkk	k000
------	------	------	------

15.2. Status Register (SREG) and Boolean Formula

I	T	H	S	V	N	Z	C
–	–	–	–	–	–	–	–

Example:

```
add r22,r23 ; Add r23 to r22
brcc nocarry ; Branch if carry cleared
...
nocarry: nop ; Branch destination (do nothing)
```

Words	1 (2 bytes)
Cycles	1 if condition is false 2 if condition is true

16. BRCS – Branch if Carry Set

16.1. Description

Conditional relative branch. Tests the Carry Flag (C) and branches relatively to PC if C is set. This instruction branches relatively to PC in either direction ($PC - 63 \leq \text{destination} \leq PC + 64$). Parameter k is the offset from PC and is represented in two's complement form. (Equivalent to instruction BRBS 0,k.)

Operation:

- (i) If $C = 1$ then $PC \leftarrow PC + k + 1$, else $PC \leftarrow PC + 1$

Syntax:

Operands:

Program Counter:

- (i) BRCS k

$-64 \leq k \leq +63$

$PC \leftarrow PC + k + 1$

$PC \leftarrow PC + 1$, if condition is false

16-bit Opcode:

1111	00kk	kkkk	k000
------	------	------	------

16.2. Status Register (SREG) and Boolean Formula

I	T	H	S	V	N	Z	C
–	–	–	–	–	–	–	–

Example:

```
    cpi r26,$56 ; Compare r26 with $56
    brcs carry ; Branch if carry set
    ...
    carry: nop ; Branch destination (do nothing)
```

Words	1 (2 bytes)
Cycles	1 if condition is false 2 if condition is true

17. BREAK – Break

17.1. Description

The BREAK instruction is used by the On-chip Debug system, and is normally not used in the application software. When the BREAK instruction is executed, the AVR CPU is set in the Stopped Mode. This gives the On-chip Debugger access to internal resources.

If any Lock bits are set, or either the JTAGEN or OCDEN Fuses are unprogrammed, the CPU will treat the BREAK instruction as a NOP and will not enter the Stopped mode.

This instruction is not available in all devices. Refer to the device specific instruction set summary.

Operation:

- (i) On-chip Debug system break.

Syntax:

Operands:

Program Counter:

- (i) BREAK

None

$PC \leftarrow PC + 1$

16-bit Opcode:

1001	0101	1001	1000
------	------	------	------

17.2. Status Register (SREG) and Boolean Formula

I	T	H	S	V	N	Z	C
–	–	–	–	–	–	–	–

Words 1 (2 bytes)

Cycles 1

18. BREQ – Branch if Equal

18.1. Description

Conditional relative branch. Tests the Zero Flag (Z) and branches relatively to PC if Z is set. If the instruction is executed immediately after any of the instructions CP, CPI, SUB, or SUBI, the branch will occur if and only if the unsigned or signed binary number represented in Rd was equal to the unsigned or signed binary number represented in Rr. This instruction branches relatively to PC in either direction ($PC - 63 \leq \text{destination} \leq PC + 64$). Parameter k is the offset from PC and is represented in two's complement form. (Equivalent to instruction BRBS 1,k.)

Operation:

- (i) If $Rd = Rr$ ($Z = 1$) then $PC \leftarrow PC + k + 1$, else $PC \leftarrow PC + 1$

Syntax:

- (i) BREQ k

Operands:

$$-64 \leq k \leq +63$$

Program Counter:

$$PC \leftarrow PC + k + 1$$

$PC \leftarrow PC + 1$, if condition is false

16-bit Opcode:

1111	00kk	kkkk	k001
------	------	------	------

18.2. Status Register (SREG) and Boolean Formula

I	T	H	S	V	N	Z	C
–	–	–	–	–	–	–	–

Example:

```
cp r1,r0 ; Compare registers r1 and r0
breq equal ; Branch if registers equal
...
equal: nop ; Branch destination(do nothing)
```

Words	1 (2 bytes)
Cycles	1 if condition is false 2 if condition is true

19. BRGE – Branch if Greater or Equal (Signed)

19.1. Description

Conditional relative branch. Tests the Signed Flag (S) and branches relatively to PC if S is cleared. If the instruction is executed immediately after any of the instructions CP, CPI, SUB, or SUBI, the branch will occur if and only if the signed binary number represented in Rd was greater than or equal to the signed binary number represented in Rr. This instruction branches relatively to PC in either direction ($PC - 63 \leq \text{destination} \leq PC + 64$). Parameter k is the offset from PC and is represented in two's complement form. (Equivalent to instruction BRBC 4,k.)

Operation:

- (i) If $Rd \geq Rr$ ($N \oplus V = 0$) then $PC \leftarrow PC + k + 1$, else $PC \leftarrow PC + 1$

Syntax:

Operands:

Program Counter:

- (i) BRGE k

$-64 \leq k \leq +63$

$PC \leftarrow PC + k + 1$

$PC \leftarrow PC + 1$, if condition is false

16-bit Opcode:

1111	01kk	kkkk	k100
------	------	------	------

19.2. Status Register (SREG) and Boolean Formula

I	T	H	S	V	N	Z	C
–	–	–	–	–	–	–	–

Example:

```
cp r11,r12 ; Compare registers r11 and r12
brge greateq ; Branch if r11 > r12 (signed)
...
greateq: nop ; Branch destination (do nothing)
```

Words

1 (2 bytes)

Cycles

1 if condition is false

2 if condition is true

20. BRHC – Branch if Half Carry Flag is Cleared

20.1. Description

Conditional relative branch. Tests the Half Carry Flag (H) and branches relatively to PC if H is cleared. This instruction branches relatively to PC in either direction ($PC - 63 \leq \text{destination} \leq PC + 64$). Parameter k is the offset from PC and is represented in two's complement form. (Equivalent to instruction BRBC 5,k.)

Operation:

- (i) If $H = 0$ then $PC \leftarrow PC + k + 1$, else $PC \leftarrow PC + 1$

Syntax:

Operands:

Program Counter:

- (i) BRHC k

$-64 \leq k \leq +63$

$PC \leftarrow PC + k + 1$

$PC \leftarrow PC + 1$, if condition is false

16-bit Opcode:

1111	01kk	kkkk	k101
------	------	------	------

20.2. Status Register (SREG) and Boolean Formula

I	T	H	S	V	N	Z	C
–	–	–	–	–	–	–	–

Example:

```
brhc hclear ; Branch if Half Carry Flag cleared
...
hclear: nop ; Branch destination (do nothing)
```

Words 1 (2 bytes)

Cycles 1 if condition is false

2 if condition is true

21. BRHS – Branch if Half Carry Flag is Set

21.1. Description

Conditional relative branch. Tests the Half Carry Flag (H) and branches relatively to PC if H is set. This instruction branches relatively to PC in either direction ($PC - 63 \leq \text{destination} \leq PC + 64$). Parameter k is the offset from PC and is represented in two's complement form. (Equivalent to instruction BRBS 5,k.)

Operation:

- (i) If $H = 1$ then $PC \leftarrow PC + k + 1$, else $PC \leftarrow PC + 1$

Syntax:

- (i) BRHS k

Operands:

$$-64 \leq k \leq +63$$

Program Counter:

$$PC \leftarrow PC + k + 1$$

$PC \leftarrow PC + 1$, if condition is false

16-bit Opcode:

1111	00kk	kkkk	k101
------	------	------	------

21.2. Status Register (SREG) and Boolean Formula

I	T	H	S	V	N	Z	C
–	–	–	–	–	–	–	–

Example:

```
brhs hset ; Branch if Half Carry Flag set
...
hset: nop ; Branch destination (do nothing)
```

Words	1 (2 bytes)
Cycles	1 if condition is false 2 if condition is true

22. BRID – Branch if Global Interrupt is Disabled

22.1. Description

Conditional relative branch. Tests the Global Interrupt Flag (I) and branches relatively to PC if I is cleared. This instruction branches relatively to PC in either direction ($PC - 63 \leq \text{destination} \leq PC + 64$). Parameter k is the offset from PC and is represented in two's complement form. (Equivalent to instruction BRBC 7,k.)

Operation:

- (i) If $I = 0$ then $PC \leftarrow PC + k + 1$, else $PC \leftarrow PC + 1$

Syntax:

Operands:

Program Counter:

- (i) BRID k

$-64 \leq k \leq +63$

$PC \leftarrow PC + k + 1$

$PC \leftarrow PC + 1$, if condition is false

16-bit Opcode:

1111	01kk	kkkk	k111
------	------	------	------

22.2. Status Register (SREG) and Boolean Formula

I	T	H	S	V	N	Z	C
–	–	–	–	–	–	–	–

Example:

```
brid intdis ; Branch if interrupt disabled
...
intdis: nop ; Branch destination (do nothing)
```

Words 1 (2 bytes)

Cycles 1 if condition is false
2 if condition is true

23. BRIE – Branch if Global Interrupt is Enabled

23.1. Description

Conditional relative branch. Tests the Global Interrupt Flag (I) and branches relatively to PC if I is set. This instruction branches relatively to PC in either direction ($PC - 63 \leq \text{destination} \leq PC + 64$). Parameter k is the offset from PC and is represented in two's complement form. (Equivalent to instruction BRBS 7,k.)

Operation:

- (i) If $I = 1$ then $PC \leftarrow PC + k + 1$, else $PC \leftarrow PC + 1$

Syntax:

Operands:

Program Counter:

- (i) BRIE k

$-64 \leq k \leq +63$

$PC \leftarrow PC + k + 1$

$PC \leftarrow PC + 1$, if condition is false

16-bit Opcode:

1111	00kk	kkkk	k111
------	------	------	------

23.2. Status Register (SREG) and Boolean Formula

I	T	H	S	V	N	Z	C
–	–	–	–	–	–	–	–

Example:

```
brie inten ; Branch if interrupt enabled
...
inten: nop ; Branch destination (do nothing)
```

Words	1 (2 bytes)
Cycles	1 if condition is false 2 if condition is true

24. BRLO – Branch if Lower (Unsigned)

24.1. Description

Conditional relative branch. Tests the Carry Flag (C) and branches relatively to PC if C is set. If the instruction is executed immediately after any of the instructions CP, CPI, SUB, or SUBI, the branch will occur if and only if, the unsigned binary number represented in Rd was smaller than the unsigned binary number represented in Rr. This instruction branches relatively to PC in either direction ($PC - 63 \leq \text{destination} \leq PC + 64$). Parameter k is the offset from PC and is represented in two's complement form. (Equivalent to instruction BRBS 0,k.)

Operation:

- (i) If $Rd < Rr$ ($C = 1$) then $PC \leftarrow PC + k + 1$, else $PC \leftarrow PC + 1$

Syntax:

Operands:

Program Counter:

- (i) BRLO k

$-64 \leq k \leq +63$

$PC \leftarrow PC + k + 1$

$PC \leftarrow PC + 1$, if condition is false

16-bit Opcode:

1111	00kk	kkkk	k000
------	------	------	------

24.2. Status Register (SREG) and Boolean Formula

I	T	H	S	V	N	Z	C
–	–	–	–	–	–	–	–

Example:

```
eor r19,r19 ; Clear r19
loop: inc r19 ; Increase r19
...
cpi r19,$10 ; Compare r19 with $10
brlo loop ; Branch if r19 < $10 (unsigned)
nop ; Exit from loop (do nothing)
```

Words 1 (2 bytes)

Cycles 1 if condition is false
2 if condition is true

25. BRLT – Branch if Less Than (Signed)

25.1. Description

Conditional relative branch. Tests the Signed Flag (S) and branches relatively to PC if S is set. If the instruction is executed immediately after any of the instructions CP, CPI, SUB, or SUBI, the branch will occur if and only if, the signed binary number represented in Rd was less than the signed binary number represented in Rr. This instruction branches relatively to PC in either direction ($PC - 63 \leq \text{destination} \leq PC + 64$). Parameter k is the offset from PC and is represented in two's complement form. (Equivalent to instruction BRBS 4,k.)

Operation:

- (i) If $Rd < Rr$ ($N \oplus V = 1$) then $PC \leftarrow PC + k + 1$, else $PC \leftarrow PC + 1$

Syntax:

Operands:

Program Counter:

- (i) BRLT k

$-64 \leq k \leq +63$

$PC \leftarrow PC + k + 1$

$PC \leftarrow PC + 1$, if condition is false

16-bit Opcode:

1111	00kk	kkkk	k100
------	------	------	------

25.2. Status Register (SREG) and Boolean Formula

I	T	H	S	V	N	Z	C
–	–	–	–	–	–	–	–

Example:

```
cp r16,r1 ; Compare r16 to r1
brlt less ; Branch if r16 < r1 (signed)
...
less: nop ; Branch destination (do nothing)
```

Words

1 (2 bytes)

Cycles

1 if condition is false

2 if condition is true

26. BRMI – Branch if Minus

26.1. Description

Conditional relative branch. Tests the Negative Flag (N) and branches relatively to PC if N is set. This instruction branches relatively to PC in either direction ($PC - 63 \leq \text{destination} \leq PC + 64$). Parameter k is the offset from PC and is represented in two's complement form. (Equivalent to instruction BRBS 2,k.)

Operation:

- (i) If $N = 1$ then $PC \leftarrow PC + k + 1$, else $PC \leftarrow PC + 1$

Syntax:

Operands:

Program Counter:

- (i) BRMI k

$-64 \leq k \leq +63$

$PC \leftarrow PC + k + 1$

$PC \leftarrow PC + 1$, if condition is false

16-bit Opcode:

1111	00kk	kkkk	k010
------	------	------	------

26.2. Status Register (SREG) and Boolean Formula

I	T	H	S	V	N	Z	C
–	–	–	–	–	–	–	–

Example:

```
subi r18,4 ; Subtract 4 from r18
brmi negative ; Branch if result negative
...
negative: nop ; Branch destination (do nothing)
```

Words	1 (2 bytes)
Cycles	1 if condition is false 2 if condition is true

27. BRNE – Branch if Not Equal

27.1. Description

Conditional relative branch. Tests the Zero Flag (Z) and branches relatively to PC if Z is cleared. If the instruction is executed immediately after any of the instructions CP, CPI, SUB, or SUBI, the branch will occur if and only if, the unsigned or signed binary number represented in Rd was not equal to the unsigned or signed binary number represented in Rr. This instruction branches relatively to PC in either direction ($PC - 63 \leq \text{destination} \leq PC + 64$). Parameter k is the offset from PC and is represented in two's complement form. (Equivalent to instruction BRBC 1,k.)

Operation:

- (i) If $Rd \neq Rr$ ($Z = 0$) then $PC \leftarrow PC + k + 1$, else $PC \leftarrow PC + 1$

Syntax:

- (i) BRNE k

Operands:

$$-64 \leq k \leq +6$$

Program Counter:

$$PC \leftarrow PC + k + 1$$

$PC \leftarrow PC + 1$, if condition is false

16-bit Opcode:

1111	01kk	kkkk	k001
------	------	------	------

27.2. Status Register (SREG) and Boolean Formula

I	T	H	S	V	N	Z	C
–	–	–	–	–	–	–	–

Example:

```
eor r27,r27 ; Clear r27
loop: inc r27 ; Increase r27
...
cpi r27,5 ; Compare r27 to 5
brne loop ; Branch if r27<>5
nop ; Loop exit (do nothing)
```

Words	1 (2 bytes)
Cycles	1 if condition is false 2 if condition is true

28. BRPL – Branch if Plus

28.1. Description

Conditional relative branch. Tests the Negative Flag (N) and branches relatively to PC if N is cleared. This instruction branches relatively to PC in either direction ($PC - 63 \leq \text{destination} \leq PC + 64$). Parameter k is the offset from PC and is represented in two's complement form. (Equivalent to instruction BRBC 2,k.)

Operation:

- (i) If $N = 0$ then $PC \leftarrow PC + k + 1$, else $PC \leftarrow PC + 1$

Syntax:

Operands:

Program Counter:

- (i) BRPL k

$-64 \leq k \leq +63$

$PC \leftarrow PC + k + 1$

$PC \leftarrow PC + 1$, if condition is false

16-bit Opcode:

1111	01kk	kkkk	k010
------	------	------	------

28.2. Status Register (SREG) and Boolean Formula

I	T	H	S	V	N	Z	C
–	–	–	–	–	–	–	–

Example:

```
subi r26,$50 ; Subtract $50 from r26
brpl positive ; Branch if r26 positive
...
positive: nop ; Branch destination (do nothing)
```

Words 1 (2 bytes)

Cycles 1 if condition is false
2 if condition is true

29. BRSH – Branch if Same or Higher (Unsigned)

29.1. Description

Conditional relative branch. Tests the Carry Flag (C) and branches relatively to PC if C is cleared. If the instruction is executed immediately after execution of any of the instructions CP, CPI, SUB, or SUBI, the branch will occur if and only if, the unsigned binary number represented in Rd was greater than or equal to the unsigned binary number represented in Rr. This instruction branches relatively to PC in either direction ($PC - 63 \leq \text{destination} \leq PC + 64$). Parameter k is the offset from PC and is represented in two's complement form. (Equivalent to instruction BRBC 0,k.)

Operation:

- (i) If $Rd \geq Rr$ ($C = 0$) then $PC \leftarrow PC + k + 1$, else $PC \leftarrow PC + 1$

Syntax:

- (i) BRSH k

Operands:

$$-64 \leq k \leq +63$$

Program Counter:

$$PC \leftarrow PC + k + 1$$

$PC \leftarrow PC + 1$, if condition is false

16-bit Opcode:

1111	01kk	kkkk	k000
------	------	------	------

29.2. Status Register (SREG) and Boolean Formula

I	T	H	S	V	N	Z	C
–	–	–	–	–	–	–	–

Example:

```
subi r19,4 ; Subtract 4 from r19
brsh highsm ; Branch if r19 >= 4 (unsigned)
...
highsm: nop ; Branch destination (do nothing)
```

Words 1 (2 bytes)

Cycles 1 if condition is false
2 if condition is true

30. BRTC – Branch if the T Flag is Cleared

30.1. Description

Conditional relative branch. Tests the T Flag and branches relatively to PC if T is cleared. This instruction branches relatively to PC in either direction ($PC - 63 \leq \text{destination} \leq PC + 64$). Parameter k is the offset from PC and is represented in two's complement form. (Equivalent to instruction BRBC 6,k.)

Operation:

- (i) If $T = 0$ then $PC \leftarrow PC + k + 1$, else $PC \leftarrow PC + 1$

Syntax:

Operands:

Program Counter:

- (i) BRTC k

$-64 \leq k \leq +63$

$PC \leftarrow PC + k + 1$

$PC \leftarrow PC + 1$, if condition is false

16-bit Opcode:

1111	01kk	kkkk	k110
------	------	------	------

30.2. Status Register (SREG) and Boolean Formula

I	T	H	S	V	N	Z	C
–	–	–	–	–	–	–	–

Example:

```
bst r3,5 ; Store bit 5 of r3 in T Flag
brtc tclear ; Branch if this bit was cleared
...
tclear: nop ; Branch destination (do nothing)
```

Words

1 (2 bytes)

Cycles

1 if condition is false

2 if condition is true

31. BRTS – Branch if the T Flag is Set

31.1. Description

Conditional relative branch. Tests the T Flag and branches relatively to PC if T is set. This instruction branches relatively to PC in either direction ($PC - 63 \leq \text{destination} \leq PC + 64$). Parameter k is the offset from PC and is represented in two's complement form. (Equivalent to instruction BRBS 6,k.)

Operation:

- (i) If $T = 1$ then $PC \leftarrow PC + k + 1$, else $PC \leftarrow PC + 1$

Syntax:

Operands:

Program Counter:

- (i) BRTS k

$-64 \leq k \leq +63$

$PC \leftarrow PC + k + 1$

$PC \leftarrow PC + 1$, if condition is false

16-bit Opcode:

1111	00kk	kkkk	k110
------	------	------	------

31.2. Status Register (SREG) and Boolean Formula

I	T	H	S	V	N	Z	C
–	–	–	–	–	–	–	–

Example:

```
bst r3,5 ; Store bit 5 of r3 in T Flag
brts tset ; Branch if this bit was set
...
tset: nop ; Branch destination (do nothing)
```

Words

1 (2 bytes)

Cycles

1 if condition is false

2 if condition is true

32. BRVC – Branch if Overflow Cleared

32.1. Description

Conditional relative branch. Tests the Overflow Flag (V) and branches relatively to PC if V is cleared. This instruction branches relatively to PC in either direction ($PC - 63 \leq \text{destination} \leq PC + 64$). Parameter k is the offset from PC and is represented in two's complement form. (Equivalent to instruction BRBC 3,k.)

Operation:

- (i) If $V = 0$ then $PC \leftarrow PC + k + 1$, else $PC \leftarrow PC + 1$

Syntax:

Operands:

Program Counter:

- (i) BRVC k

$-64 \leq k \leq +63$

$PC \leftarrow PC + k + 1$

$PC \leftarrow PC + 1$, if condition is false

16-bit Opcode:

1111	01kk	kkkk	k011
------	------	------	------

32.2. Status Register (SREG) and Boolean Formula

I	T	H	S	V	N	Z	C
–	–	–	–	–	–	–	–

Example:

```
add r3,r4 ; Add r4 to r3
brvc noover ; Branch if no overflow
...
noover: nop ; Branch destination (do nothing)
```

Words

1 (2 bytes)

Cycles

1 if condition is false

2 if condition is true

33. BRVS – Branch if Overflow Set

33.1. Description

Conditional relative branch. Tests the Overflow Flag (V) and branches relatively to PC if V is set. This instruction branches relatively to PC in either direction ($PC - 63 \leq \text{destination} \leq PC + 64$). Parameter k is the offset from PC and is represented in two's complement form. (Equivalent to instruction BRBS 3,k.)

Operation:

- (i) If $V = 1$ then $PC \leftarrow PC + k + 1$, else $PC \leftarrow PC + 1$

Syntax:

Operands:

Program Counter:

- (i) BRVS k

$-64 \leq k \leq +63$

$PC \leftarrow PC + k + 1$

$PC \leftarrow PC + 1$, if condition is false

16-bit Opcode:

1111	00kk	kkkk	k011
------	------	------	------

33.2. Status Register (SREG) and Boolean Formula

I	T	H	S	V	N	Z	C
–	–	–	–	–	–	–	–

Example:

```
add r3,r4 ; Add r4 to r3
brvs overfl ; Branch if overflow
...
overfl: nop ; Branch destination (do nothing)
```

Words

1 (2 bytes)

Cycles

1 if condition is false

2 if condition is true

34. BSET – Bit Set in SREG

34.1. Description

Sets a single Flag or bit in SREG.

Operation:

- (i) $SREG(s) \leftarrow 1$

Syntax:

- (i) BSET s

Operands:

$$0 \leq s \leq 7$$

Program Counter:

$$PC \leftarrow PC + 1$$

16-bit Opcode:

1001	0100	0sss	1000
------	------	------	------

34.2. Status Register (SREG) and Boolean Formula

I	T	H	S	V	N	Z	C
↔	↔	↔	↔	↔	↔	↔	↔

I 1 if s = 7; Unchanged otherwise.

T 1 if s = 6; Unchanged otherwise.

H 1 if s = 5; Unchanged otherwise.

S 1 if s = 4; Unchanged otherwise.

V 1 if s = 3; Unchanged otherwise.

N 1 if s = 2; Unchanged otherwise.

Z 1 if s = 1; Unchanged otherwise.

C 1 if s = 0; Unchanged otherwise.

Example:

```
bset 6 ; Set T Flag
bset 7 ; Enable interrupt
```

Words 1 (2 bytes)

Cycles 1

35. BST – Bit Store from Bit in Register to T Flag in SREG

35.1. Description

Stores bit b from Rd to the T Flag in SREG (Status Register).

Operation:

(i) $T \leftarrow Rd(b)$

Syntax:

(i) $BST\ Rd,b$

Operands:

$0 \leq d \leq 31, 0 \leq b \leq 7$

Program Counter:

$PC \leftarrow PC + 1$

16-bit Opcode:

1111	101d	dddd	0bbb
------	------	------	------

35.2. Status Register (SREG) and Boolean Formula

I	T	H	S	V	N	Z	C
–	↔	–	–	–	–	–	–

T 0 if bit b in Rd is cleared. Set to 1 otherwise.

Example:

```
; Copy bit  
bst r1,2 ; Store bit 2 of r1 in T Flag  
bld r0,4 ; Load T into bit 4 of r0
```

Words 1 (2 bytes)

Cycles 1

36. CALL – Long Call to a Subroutine

36.1. Description

Calls to a subroutine within the entire Program memory. The return address (to the instruction after the CALL) will be stored onto the Stack. (See also RCALL). The Stack Pointer uses a post-decrement scheme during CALL.

This instruction is not available in all devices. Refer to the device specific instruction set summary.

Operation:

- (i) $PC \leftarrow k$ Devices with 16-bit PC, 128KB Program memory maximum.
- (ii) $PC \leftarrow k$ Devices with 22-bit PC, 8MB Program memory maximum.

Syntax:	Operands:	Program Counter:	Stack:
(i) CALL k	$0 \leq k < 64K$	$PC \leftarrow k$	STACK $\leftarrow PC+2$ SP $\leftarrow SP-2$, (2 bytes, 16 bits)
(ii) CALL k	$0 \leq k < 4M$	$PC \leftarrow k$	STACK $\leftarrow PC+2$ SP $\leftarrow SP-3$ (3 bytes, 22 bits)

32-bit Opcode:

1001	010k	kkkk	111k
kkkk	kkkk	kkkk	kkkk

36.2. Status Register (SREG) and Boolean Formula

I	T	H	S	V	N	Z	C
–	–	–	–	–	–	–	–

Example:

```

mov r16,r0 ; Copy r0 to r16
call check ; Call subroutine
nop ; Continue (do nothing)
...
check: cpi r16,$42 ; Check if r16 has a special value
breq error ; Branch if equal
ret ; Return from subroutine
...
error: rjmp error ; Infinite loop
    
```

Words

2 (4 bytes)

Cycles

4 devices with 16-bit PC

Cycles XMEGA

5 devices with 22-bit PC

3 devices with 16-bit PC

4 devices with 22-bit PC

37. CBI – Clear Bit in I/O Register

37.1. Description

Clears a specified bit in an I/O register. This instruction operates on the lower 32 I/O registers – addresses 0-31.

Operation:

(i) $I/O(A,b) \leftarrow 0$

Syntax:

(i) CBI A,b

Operands:

$0 \leq A \leq 31, 0 \leq b \leq 7$

Program Counter:

$PC \leftarrow PC + 1$

16-bit Opcode:

1001	1000	AAAA	Abbb
------	------	------	------

37.2. Status Register (SREG) and Boolean Formula

I	T	H	S	V	N	Z	C
–	–	–	–	–	–	–	–

Example:

```
cbi $12,7 ; Clear bit 7 in Port D
```

Words	1 (2 bytes)
Cycles	2
Cycles XMEGA	1
Cycles Reduced Core tinyAVR	1

38. CBR – Clear Bits in Register

38.1. Description

Clears the specified bits in register Rd. Performs the logical AND between the contents of register Rd and the complement of the constant mask K. The result will be placed in register Rd.

Operation:

$$(i) \quad R_d \leftarrow R_d \cdot (\$FF - K)$$

Syntax:

Operands:

Program Counter:

$$(i) \quad \text{CBR } R_d, K$$

$$16 \leq d \leq 31, 0 \leq K \leq 255$$

$$PC \leftarrow PC + 1$$

16-bit Opcode: (see ANDI with K complemented)

38.2. Status Register (SREG) and Boolean Formula

I	T	H	S	V	N	Z	C
–	–	–	↔	0	↔	↔	–

S $N \oplus V$, for signed tests.

V 0

Cleared.

N R7

Set if MSB of the result is set; cleared otherwise.

Z $\overline{R7} \cdot \overline{R6} \cdot \overline{R5} \cdot \overline{R4} \cdot \overline{R3} \cdot \overline{R2} \cdot \overline{R1} \cdot \overline{R0}$

Set if the result is \$00; cleared otherwise.

R (Result) equals Rd after the operation.

Example:

```
cbr r16,$F0 ; Clear upper nibble of r16
cbr r18,1 ; Clear bit 0 in r18
```

Words 1 (2 bytes)

Cycles 1

41. CLI – Clear Global Interrupt Flag

41.1. Description

Clears the Global Interrupt Flag (I) in SREG (Status Register). The interrupts will be immediately disabled. No interrupt will be executed after the CLI instruction, even if it occurs simultaneously with the CLI instruction.

Operation:

- (i) $I \leftarrow 0$

Syntax:

Operands:

Program Counter:

- (i) CLI

None

$PC \leftarrow PC + 1$

16-bit Opcode:

1001	0100	1111	1000
------	------	------	------

41.2. Status Register (SREG) and Boolean Formula

I	T	H	S	V	N	Z	C
0	–	–	–	–	–	–	–

I 0

Global Interrupt Flag cleared.

Example:

```
in temp, SREG ; Store SREG value (temp must be defined by user)
cli ; Disable interrupts during timed sequence
sbi EECR, EEMWE ; Start EEPROM write
sbi EECR, EEWE
out SREG, temp ; Restore SREG value (I-Flag)
```

Words 1 (2 bytes)

Cycles 1

43. CLR – Clear Register

43.1. Description

Clears a register. This instruction performs an Exclusive OR between a register and itself. This will clear all bits in the register.

Operation:

(i) $Rd \leftarrow Rd \oplus Rd$

Syntax:

Operands:

Program Counter:

(i) CLR Rd

$0 \leq d \leq 31$

$PC \leftarrow PC + 1$

16-bit Opcode: (see EOR Rd,Rd)

0010	01dd	dddd	dddd
------	------	------	------

43.2. Status Register (SREG) and Boolean Formula

I	T	H	S	V	N	Z	C
–	–	–	0	0	0	1	–

S 0
Cleared.

V 0
Cleared.

N 0
Cleared.

Z 1
Set.

R (Result) equals Rd after the operation.

Example:

```
clr r18 ; clear r18
loop: inc r18 ; increase r18
...
cpi r18,$50 ; Compare r18 to $50
brne loop
```

Words 1 (2 bytes)

Cycles 1

48. COM – One’s Complement

48.1. Description

This instruction performs a One’s Complement of register Rd.

Operation:

(i) $Rd \leftarrow \$FF - Rd$

Syntax:

(i) COM Rd

Operands:

$0 \leq d \leq 31$

Program Counter:

$PC \leftarrow PC + 1$

16-bit Opcode:

1001	010d	dddd	0000
------	------	------	------

48.2. Status Register (SREG) and Boolean Formula

I	T	H	S	V	N	Z	C
–	–	–	\Leftrightarrow	0	\Leftrightarrow	\Leftrightarrow	1

S $N \oplus V$, for signed tests.

V 0
Cleared.

N R7
Set if MSB of the result is set; cleared otherwise.

Z $\overline{R7} \cdot \overline{R6} \cdot \overline{R5} \cdot \overline{R4} \cdot \overline{R3} \cdot \overline{R2} \cdot \overline{R1} \cdot \overline{R0}$
Set if the result is \$00; cleared otherwise.

C 1
Set.

R (Result) equals Rd after the operation.

Example:

```
com r4 ; Take one's complement of r4
breq zero ; Branch if zero
...
zero: nop ; Branch destination (do nothing)
```

Words 1 (2 bytes)

Cycles 1

49. CP – Compare

49.1. Description

This instruction performs a compare between two registers Rd and Rr. None of the registers are changed. All conditional branches can be used after this instruction.

Operation:

- (i) Rd - Rr

Syntax:

- (i) CP Rd,Rr

Operands:

$0 \leq d \leq 31, 0 \leq r \leq 31$

Program Counter:

PC ← PC + 1

16-bit Opcode:

0001	01rd	dddd	rrrr
------	------	------	------

49.2. Status Register (SREG) and Boolean Formula

I	T	H	S	V	N	Z	C
–	–	↔	↔	↔	↔	↔	↔

H $\overline{Rd3} \cdot Rr3 + Rr3 \cdot R3 + R3 \cdot \overline{Rd3}$

Set if there was a borrow from bit 3; cleared otherwise.

S $N \oplus V$, for signed tests.

V $Rd7 \cdot \overline{Rr7} \cdot \overline{R7} + \overline{Rd7} \cdot Rr7 \cdot R7$

Set if two's complement overflow resulted from the operation; cleared otherwise.

N R7

Set if MSB of the result is set; cleared otherwise.

Z $\overline{R7} \cdot \overline{R6} \cdot \overline{R5} \cdot \overline{R4} \cdot \overline{R3} \cdot \overline{R2} \cdot \overline{R1} \cdot \overline{R0}$

Set if the result is \$00; cleared otherwise.

C $\overline{Rd7} \cdot Rr7 + Rr7 \cdot R7 + R7 \cdot \overline{Rd7}$

Set if the absolute value of the contents of Rr is larger than the absolute value of Rd; cleared otherwise.

R (Result) after the operation.

Example:

```
cp r4,r19 ; Compare r4 with r19
brne noteq ; Branch if r4 <> r19
...
noteq: nop ; Branch destination (do nothing)
```

Words

1 (2 bytes)

Cycles

1

50. CPC – Compare with Carry

50.1. Description

This instruction performs a compare between two registers Rd and Rr and also takes into account the previous carry. None of the registers are changed. All conditional branches can be used after this instruction.

Operation:

- (i) $Rd - Rr - C$

Syntax:

- (i) CPC Rd,Rr

Operands:

- $0 \leq d \leq 31, 0 \leq r \leq 31$

Program Counter:

- $PC \leftarrow PC + 1$

16-bit Opcode:

0000	01rd	dddd	rrrr
------	------	------	------

50.2. Status Register (SREG) and Boolean Formula

I	T	H	S	V	N	Z	C
–	–	↔	↔	↔	↔	↔	↔

$$\mathbf{H} \overline{Rd3} \cdot Rr3 + Rr3 \cdot R3 + R3 \cdot \overline{Rd3}$$

Set if there was a borrow from bit 3; cleared otherwise.

$$\mathbf{S} N \oplus V, \text{ for signed tests.}$$

$$\mathbf{V} Rd7 \cdot \overline{Rr7} \cdot \overline{R7} + \overline{Rd7} \cdot Rr7 \cdot R7$$

Set if two's complement overflow resulted from the operation; cleared otherwise.

$$\mathbf{N} R7$$

Set if MSB of the result is set; cleared otherwise.

$$\mathbf{Z} \overline{R7} \cdot \overline{R6} \cdot \overline{R5} \cdot \overline{R4} \cdot \overline{R3} \cdot \overline{R2} \cdot \overline{R1} \cdot \overline{R0} \cdot Z$$

Previous value remains unchanged when the result is zero; cleared otherwise.

$$\mathbf{C} \overline{Rd7} \cdot Rr7 + Rr7 \cdot R7 + R7 \cdot \overline{Rd7}$$

Set if the absolute value of the contents of Rr plus previous carry is larger than the absolute value of Rd; cleared otherwise.

R (Result) after the operation.

Example:

```
; Compare r3:r2 with r1:r0
cp r2,r0 ; Compare low byte
cpc r3,r1 ; Compare high byte
```

```
brne noteq ; Branch if not equal
...
noteq: nop ; Branch destination (do nothing)
```

Words	1 (2 bytes)
Cycles	1

51. CPI – Compare with Immediate

51.1. Description

This instruction performs a compare between register Rd and a constant. The register is not changed. All conditional branches can be used after this instruction.

Operation:

- (i) $Rd - K$

Syntax:

- (i) $CPI\ Rd,K$

Operands:

- $16 \leq d \leq 31, 0 \leq K \leq 255$

Program Counter:

- $PC \leftarrow PC + 1$

16-bit Opcode:

0011	KKKK	dddd	KKKK
------	------	------	------

51.2. Status Register (SREG) and Boolean Formula

I	T	H	S	V	N	Z	C
–	–	↔	↔	↔	↔	↔	↔

$$H \quad \overline{Rd3} \cdot K3 + K3 \cdot R3 + R3 \cdot \overline{Rd3}$$

Set if there was a borrow from bit 3; cleared otherwise.

$$S \quad N \oplus V, \text{ for signed tests.}$$

$$V \quad Rd7 \cdot \overline{K7} \cdot \overline{R7} + \overline{Rd7} \cdot K7 \cdot R7$$

Set if two's complement overflow resulted from the operation; cleared otherwise.

$$N \quad R7$$

Set if MSB of the result is set; cleared otherwise.

$$Z \quad \overline{R7} \cdot \overline{R6} \cdot \overline{R5} \cdot \overline{R4} \cdot \overline{R3} \cdot \overline{R2} \cdot \overline{R1} \cdot \overline{R0}$$

Set if the result is \$00; cleared otherwise.

$$C \quad \overline{Rd7} \cdot K7 + K7 \cdot R7 + R7 \cdot \overline{Rd7}$$

Set if the absolute value of K is larger than the absolute value of Rd; cleared otherwise.

R (Result) after the operation.

Example:

```

cpi r19,3 ; Compare r19 with 3
brne error ; Branch if r19<>3
...
error: nop ; Branch destination (do nothing)

```

Words

1 (2 bytes)

Cycles

1

52. CPSE – Compare Skip if Equal

52.1. Description

This instruction performs a compare between two registers Rd and Rr, and skips the next instruction if Rd = Rr.

Operation:

- (i) If Rd = Rr then PC ← PC + 2 (or 3) else PC ← PC + 1

Syntax:

Operands:

Program Counter:

- (i) CPSE Rd,Rr

$0 \leq d \leq 31, 0 \leq r \leq 31$

PC ← PC + 1, Condition false - no skip

PC ← PC + 2, Skip a one word instruction

PC ← PC + 3, Skip a two word instruction

16-bit Opcode:

0001	00rd	dddd	rrrr
------	------	------	------

52.2. Status Register (SREG) and Boolean Formula

I	T	H	S	V	N	Z	C
–	–	–	–	–	–	–	–

Example:

```
inc r4 ; Increase r4
cpse r4,r0 ; Compare r4 to r0
neg r4 ; Only executed if r4<>r0
nop ; Continue (do nothing)
```

Words 1 (2 bytes)

Cycles 1 if condition is false (no skip)

2 if condition is true (skip is executed) and the instruction skipped is 1 word

3 if condition is true (skip is executed) and the instruction skipped is 2 words

53. DEC – Decrement

53.1. Description

Subtracts one -1- from the contents of register Rd and places the result in the destination register Rd.

The C Flag in SREG is not affected by the operation, thus allowing the DEC instruction to be used on a loop counter in multiple-precision computations.

When operating on unsigned values, only BREQ and BRNE branches can be expected to perform consistently. When operating on two's complement values, all signed branches are available.

Operation:

- (i) $Rd \leftarrow Rd - 1$

Syntax:

Operands:

Program Counter:

- (i) DEC Rd

$0 \leq d \leq 31$

$PC \leftarrow PC + 1$

16-bit Opcode:

1001	010d	dddd	1010
------	------	------	------

53.2. Status Register and Boolean Formula

I	T	H	S	V	N	Z	C
–	–	–	↔	↔	↔	↔	–

S $N \oplus V$, for signed tests.

V $\overline{R7} \cdot \overline{R6} \cdot \overline{R5} \cdot \overline{R4} \cdot \overline{R3} \cdot \overline{R2} \cdot \overline{R1} \cdot \overline{R0}$

Set if two's complement overflow resulted from the operation; cleared otherwise. Two's complement overflow occurs if and only if Rd was \$80 before the operation.

N R7

Set if MSB of the result is set; cleared otherwise.

Z $\overline{R7} \cdot \overline{R6} \cdot \overline{R5} \cdot \overline{R4} \cdot \overline{R3} \cdot \overline{R2} \cdot \overline{R1} \cdot \overline{R0}$

Set if the result is \$00; cleared otherwise.

R (Result) equals Rd after the operation.

Example:

```
ldi r17,$10 ; Load constant in r17
loop: add r1,r2 ; Add r2 to r1
dec r17 ; Decrement r17
brne loop ; Branch if r17<>0
nop ; Continue (do nothing)
```

Words

1 (2 bytes)

Cycles

1

54. DES – Data Encryption Standard

54.1. Description

The module is an instruction set extension to the AVR CPU, performing DES iterations. The 64-bit data block (plaintext or ciphertext) is placed in the CPU register file, registers R0-R7, where LSB of data is placed in LSB of R0 and MSB of data is placed in MSB of R7. The full 64-bit key (including parity bits) is placed in registers R8-R15, organized in the register file with LSB of key in LSB of R8 and MSB of key in MSB of R15. Executing one DES instruction performs one round in the DES algorithm. Sixteen rounds must be executed in increasing order to form the correct DES ciphertext or plaintext. Intermediate results are stored in the register file (R0-R15) after each DES instruction. The instruction's operand (K) determines which round is executed, and the half carry flag (H) determines whether encryption or decryption is performed.

The DES algorithm is described in “Specifications for the Data Encryption Standard” (Federal Information Processing Standards Publication 46). Intermediate results in this implementation differ from the standard because the initial permutation and the inverse initial permutation are performed in each iteration. This does not affect the result in the final ciphertext or plaintext, but reduces the execution time.

Operation:

- (i) If H = 0 then Encrypt round (R7-R0, R15-R8, K)
If H = 1 then Decrypt round (R7-R0, R15-R8, K)

Syntax:

Operands:

Program Counter:

- (i) DES K

$0x00 \leq K \leq 0x0F$

$PC \leftarrow PC + 1$

16-bit Opcode:

1001	0100	KKKK	1011
------	------	------	------

Example:

```
DES 0x00  
DES 0x01  
...  
DES 0x0E  
DES 0x0F
```

Words 1 (2 bytes)

Cycles 1

Note: If the DES instruction is succeeding a non-DES instruction, an extra cycle is inserted.

55. EICALL – Extended Indirect Call to Subroutine

55.1. Description

Indirect call of a subroutine pointed to by the Z (16 bits) Pointer Register in the Register File and the EIND Register in the I/O space. This instruction allows for indirect calls to the entire 4M (words) Program memory space. See also ICALL. The Stack Pointer uses a post-decrement scheme during EICALL.

This instruction is not available in all devices. Refer to the device specific instruction set summary.

Operation:

- (i) $PC(15:0) \leftarrow Z(15:0)$
 $PC(21:16) \leftarrow EIND$

Syntax:	Operands:	Program Counter:	Stack:
(i) EICALL	None	See Operation	$STACK \leftarrow PC + 1$ $SP \leftarrow SP - 3$ (3 bytes, 22 bits)

16-bit Opcode:

1001	0101	0001	1001
------	------	------	------

55.2. Status Register (SREG) and Boolean Formula

I	T	H	S	V	N	Z	C
–	–	–	–	–	–	–	–

Example:

```
ldi r16,$05 ; Set up EIND and Z-pointer
out EIND,r16
ldi r30,$00
ldi r31,$10
eicall ; Call to $051000
```

Words	1 (2 bytes)
Cycles	4 (only implemented in devices with 22-bit PC)
Cycles XMEGA	3 (only implemented in devices with 22-bit PC)

56. EIJMP – Extended Indirect Jump

56.1. Description

Indirect jump to the address pointed to by the Z (16 bits) Pointer Register in the Register File and the EIND Register in the I/O space. This instruction allows for indirect jumps to the entire 4M (words) Program memory space. See also IJMP.

This instruction is not available in all devices. Refer to the device specific instruction set summary.

Operation:

- (i) $PC(15:0) \leftarrow Z(15:0)$
 $PC(21:16) \leftarrow EIND$

Syntax:	Operands:	Program Counter:	Stack:
(i) EIJMP	None	See Operation	Not Affected

16-bit Opcode:

1001	0100	0001	1001
------	------	------	------

56.2. Status Register (SREG) and Boolean Formula

I	T	H	S	V	N	Z	C
–	–	–	–	–	–	–	–

Example:

```
ldi r16,$05 ; Set up EIND and Z-pointer
out EIND,r16
ldi r30,$00
ldi r31,$10
eijmp ; Jump to $051000
```

Words	1 (2 bytes)
Cycles	2

57. ELPM – Extended Load Program Memory

57.1. Description

Loads one byte pointed to by the Z-register and the RAMPZ Register in the I/O space, and places this byte in the destination register Rd. This instruction features a 100% space effective constant initialization or constant data fetch. The Program memory is organized in 16-bit words while the Z-pointer is a byte address. Thus, the least significant bit of the Z-pointer selects either low byte ($Z_{LSB} = 0$) or high byte ($Z_{LSB} = 1$). This instruction can address the entire Program memory space. The Z-pointer Register can either be left unchanged by the operation, or it can be incremented. The incrementation applies to the entire 24-bit concatenation of the RAMPZ and Z-pointer Registers.

Devices with Self-Programming capability can use the ELPM instruction to read the Fuse and Lock bit value. Refer to the device documentation for a detailed description.

This instruction is not available in all devices. Refer to the device specific instruction set summary.

The result of these combinations is undefined:

ELPM r30, Z+

ELPM r31, Z+

	Operation:		Comment:
(i)	$R0 \leftarrow (RAMPZ:Z)$		RAMPZ:Z: Unchanged, R0 implied destination register
(ii)	$Rd \leftarrow (RAMPZ:Z)$		RAMPZ:Z: Unchanged
(iii)	$Rd \leftarrow (RAMPZ:Z)$		(RAMPZ:Z) \leftarrow (RAMPZ:Z) + 1 RAMPZ:Z: Post incremented
	Syntax:	Operands:	Program Counter:
(i)	ELPM	None, R0 implied	$PC \leftarrow PC + 1$
(ii)	ELPM Rd, Z	$0 \leq d \leq 31$	$PC \leftarrow PC + 1$
(iii)	ELPM Rd, Z+	$0 \leq d \leq 31$	$PC \leftarrow PC + 1$

16 bit Opcode:

(i)	1001	0101	1101	1000
(ii)	1001	000d	dddd	0110
(iii)	1001	000d	dddd	0111

57.2. Status Register (SREG) and Boolean Formula

I	T	H	S	V	N	Z	C
–	–	–	–	–	–	–	–

Example:

```
ldi ZL, byte3(Table_1<<1) ; Initialize Z-pointer
out RAMPZ, ZL
ldi ZH, byte2(Table_1<<1)
ldi ZL, byte1(Table_1<<1)
elpm r16, Z+ ; Load constant from Program
; memory pointed to by RAMPZ:Z (Z is r31:r30)
...
Table_1:
.dw 0x3738 ; 0x38 is addressed when ZLSB = 0
; 0x37 is addressed when ZLSB = 1
...
```

Words 1 (2 bytes)

Cycles 3

58. EOR – Exclusive OR

58.1. Description

Performs the logical EOR between the contents of register Rd and register Rr and places the result in the destination register Rd.

Operation:

$$(i) \quad R_d \leftarrow R_d \oplus R_r$$

Syntax:

$$(i) \quad \text{EOR } R_d, R_r$$

Operands:

$$0 \leq d \leq 31, 0 \leq r \leq 3$$

Program Counter:

$$PC \leftarrow PC + 1$$

16-bit Opcode:

0010	01rd	dddd	rrrr
------	------	------	------

58.2. Status Register (SREG) and Boolean Formula

I	T	H	S	V	N	Z	C
–	–	–	↔	0	↔	↔	–

S $N \oplus V$, for signed tests.

V 0

Cleared.

N R7

Set if MSB of the result is set; cleared otherwise.

Z $\overline{R_7} \cdot \overline{R_6} \cdot \overline{R_5} \cdot \overline{R_4} \cdot \overline{R_3} \cdot \overline{R_2} \cdot \overline{R_1} \cdot \overline{R_0}$

Set if the result is \$00; cleared otherwise.

R (Result) equals Rd after the operation.

Example:

```
eor r4,r4 ; Clear r4
eor r0,r22 ; Bitwise exclusive or between r0 and r22
```

Words 1 (2 bytes)

Cycles 1

59. FMUL – Fractional Multiply Unsigned

59.1. Description

This instruction performs 8-bit × 8-bit → 16-bit unsigned multiplication and shifts the result one bit left.

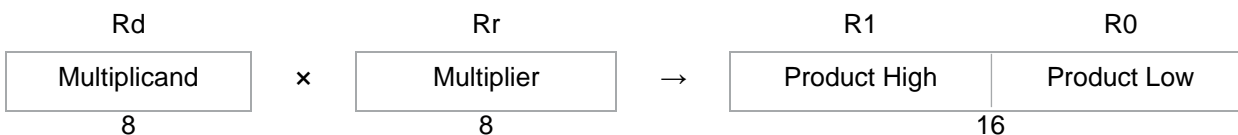

Let (N.Q) denote a fractional number with N binary digits left of the radix point, and Q binary digits right of the radix point. A multiplication between two numbers in the formats (N1.Q1) and (N2.Q2) results in the format ((N1+N2).(Q1+Q2)). For signal processing applications, the format (1.7) is widely used for the inputs, resulting in a (2.14) format for the product. A left shift is required for the high byte of the product to be in the same format as the inputs. The FMUL instruction incorporates the shift operation in the same number of cycles as MUL.

The (1.7) format is most commonly used with signed numbers, while FMUL performs an unsigned multiplication. This instruction is therefore most useful for calculating one of the partial products when performing a signed multiplication with 16-bit inputs in the (1.15) format, yielding a result in the (1.31) format. Note: the result of the FMUL operation may suffer from a 2's complement overflow if interpreted as a number in the (1.15) format. The MSB of the multiplication before shifting must be taken into account, and is found in the carry bit. See the following example.

The multiplicand Rd and the multiplier Rr are two registers containing unsigned fractional numbers where the implicit radix point lies between bit 6 and bit 7. The 16-bit unsigned fractional product with the implicit radix point between bit 14 and bit 15 is placed in R1 (high byte) and R0 (low byte).

This instruction is not available in all devices. Refer to the device specific instruction set summary.

Operation:

- (i) R1:R0 ← Rd × Rr (unsigned (1.15) ← unsigned (1.7) × unsigned (1.7))

Syntax:

Operands:

Program Counter:

- (i) FMUL Rd,Rr

16 ≤ d ≤ 23, 16 ≤ r ≤ 23

PC ← PC + 1

- (i) PC ← PC + 1

16-bit Opcode:

0000	0011	0ddd	1rrr
------	------	------	------

59.2. Status Register (SREG) and Boolean Formula

I	T	H	S	V	N	Z	C
–	–	–	–	–	–	↔	↔

C R16

Set if bit 15 of the result before left shift is set; cleared otherwise.

Z $\overline{R15} \cdot \overline{R14} \cdot \overline{R13} \cdot \overline{R12} \cdot \overline{R11} \cdot \overline{R10} \cdot \overline{R9} \cdot \overline{R8} \cdot \overline{R7} \cdot \overline{R6} \cdot \overline{R5} \cdot \overline{R4} \cdot \overline{R3} \cdot \overline{R2} \cdot \overline{R1} \cdot \overline{R0}$

Set if the result is \$0000; cleared otherwise.

R (Result) equals R1,R0 after the operation.

Example:

```
*****  
;* DESCRIPTION  
;* Signed fractional multiply of two 16-bit numbers with 32-bit result.  
;* USAGE  
;* r19:r18:r17:r16 = ( r23:r22 * r21:r20 ) << 1  
*****  
fmuls16x16_32:  
  clr r2  
  fmuls r23, r21 ;((signed)ah * (signed)bh) << 1  
  movw r19:r18, r1:r0  
  fmul r22, r20 ;(al * bl) << 1  
  adc r18, r2  
  movw r17:r16, r1:r0  
  fmulsu r23, r20 ;((signed)ah * bl) << 1  
  sbc r19, r2  
  add r17, r0  
  adc r18, r1  
  adc r19, r2  
  fmulsu r21, r22 ;((signed)bh * al) << 1  
  sbc r19, r2  
  add r17, r0  
  adc r18, r1  
  adc r19, r2
```

Words 1 (2 bytes)

Cycles 2

60. FMULS – Fractional Multiply Signed

60.1. Description

This instruction performs 8-bit × 8-bit → 16-bit signed multiplication and shifts the result one bit left.

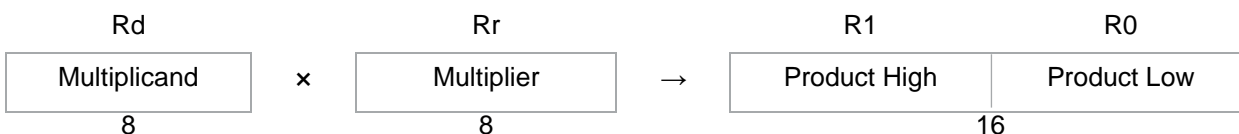

Let (N.Q) denote a fractional number with N binary digits left of the radix point, and Q binary digits right of the radix point. A multiplication between two numbers in the formats (N1.Q1) and (N2.Q2) results in the format ((N1+N2).(Q1+Q2)). For signal processing applications, the format (1.7) is widely used for the inputs, resulting in a (2.14) format for the product. A left shift is required for the high byte of the product to be in the same format as the inputs. The FMULS instruction incorporates the shift operation in the same number of cycles as MULS.

The multiplicand Rd and the multiplier Rr are two registers containing signed fractional numbers where the implicit radix point lies between bit 6 and bit 7. The 16-bit signed fractional product with the implicit radix point between bit 14 and bit 15 is placed in R1 (high byte) and R0 (low byte).

Note that when multiplying 0x80 (-1) with 0x80 (-1), the result of the shift operation is 0x8000 (-1). The shift operation thus gives a two's complement overflow. This must be checked and handled by software.

This instruction is not available in all devices. Refer to the device specific instruction set summary.

Operation:

- (i) R1:R0 ← Rd × Rr (signed (1.15) ← signed (1.7) × signed (1.7))

Syntax:

Operands:

Program Counter:

- (i) FMULS Rd,Rr

16 ≤ d ≤ 23, 16 ≤ r ≤ 23

PC ← PC + 1

16-bit Opcode:

0000	0011	1ddd	0rrr
------	------	------	------

60.2. Status Register (SREG) and Boolean Formula

I	T	H	S	V	N	Z	C
–	–	–	–	–	–	↔	↔

C R16

Set if bit 15 of the result before left shift is set; cleared otherwise.

Z $\overline{R15} \cdot \overline{R14} \cdot \overline{R13} \cdot \overline{R12} \cdot \overline{R11} \cdot \overline{R10} \cdot \overline{R9} \cdot \overline{R8} \cdot \overline{R7} \cdot \overline{R6} \cdot \overline{R5} \cdot \overline{R4} \cdot \overline{R3} \cdot \overline{R2} \cdot \overline{R1} \cdot \overline{R0}$

Set if the result is \$0000; cleared otherwise.

R (Result) equals R1,R0 after the operation.

Example:

```
fmuls r23,r22 ; Multiply signed r23 and r22 in (1.7) format, result in (1.15) format  
mov w r23:r22,r1:r0 ; Copy result back in r23:r22
```

Words 1 (2 bytes)

Cycles 2

61. FMULSU – Fractional Multiply Signed with Unsigned

61.1. Description

This instruction performs 8-bit × 8-bit → 16-bit signed multiplication and shifts the result one bit left.

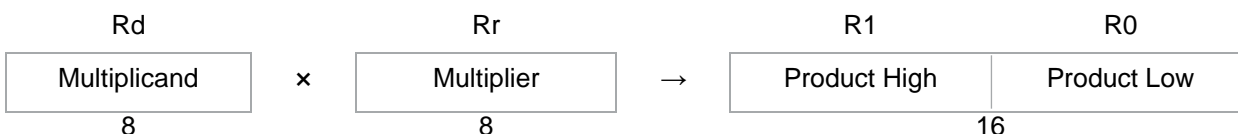

Let (N.Q) denote a fractional number with N binary digits left of the radix point, and Q binary digits right of the radix point. A multiplication between two numbers in the formats (N1.Q1) and (N2.Q2) results in the format ((N1+N2).(Q1+Q2)). For signal processing applications, the format (1.7) is widely used for the inputs, resulting in a (2.14) format for the product. A left shift is required for the high byte of the product to be in the same format as the inputs. The FMULSU instruction incorporates the shift operation in the same number of cycles as MULSU.

The (1.7) format is most commonly used with signed numbers, while FMULSU performs a multiplication with one unsigned and one signed input. This instruction is therefore most useful for calculating two of the partial products when performing a signed multiplication with 16-bit inputs in the (1.15) format, yielding a result in the (1.31) format. Note: the result of the FMULSU operation may suffer from a 2's complement overflow if interpreted as a number in the (1.15) format. The MSB of the multiplication before shifting must be taken into account, and is found in the carry bit. See the following example.

The multiplicand Rd and the multiplier Rr are two registers containing fractional numbers where the implicit radix point lies between bit 6 and bit 7. The multiplicand Rd is a signed fractional number, and the multiplier Rr is an unsigned fractional number. The 16-bit signed fractional product with the implicit radix point between bit 14 and bit 15 is placed in R1 (high byte) and R0 (low byte).

This instruction is not available in all devices. Refer to the device specific instruction set summary.

Operation:

- (i) R1:R0 ← Rd × Rr (signed (1.15) ← signed (1.7) × unsigned (1.7))

Syntax:

Operands:

Program Counter:

- (i) FMULSU Rd,Rr

16 ≤ d ≤ 23, 16 ≤ r ≤ 23

PC ← PC + 1

16-bit Opcode:

0000	0011	1ddd	1rrr
------	------	------	------

61.2. Status Register (SREG) and Boolean Formula

I	T	H	S	V	N	Z	C
–	–	–	–	–	–	↔	↔

C R16

Set if bit 15 of the result before left shift is set; cleared otherwise.

Z $\overline{R15} \cdot \overline{R14} \cdot \overline{R13} \cdot \overline{R12} \cdot \overline{R11} \cdot \overline{R10} \cdot \overline{R9} \cdot \overline{R8} \cdot \overline{R7} \cdot \overline{R6} \cdot \overline{R5} \cdot \overline{R4} \cdot \overline{R3} \cdot \overline{R2} \cdot \overline{R1} \cdot \overline{R0}$

Set if the result is \$0000; cleared otherwise.

R (Result) equals R1,R0 after the operation.

Example:

```
*****
;* DESCRIPTION
;* Signed fractional multiply of two 16-bit numbers with 32-bit result.
;* USAGE
;* r19:r18:r17:r16 = ( r23:r22 * r21:r20 ) << 1
*****
fmuls16x16_32:
  clr r2
  fmuls r23, r21 ;((signed)ah * (signed)bh) << 1
  movw r19:r18, r1:r0
  fmul r22, r20 ;(al * bl) << 1
  adc r18, r2
  movw r17:r16, r1:r0
  fmulsu r23, r20 ;((signed)ah * bl) << 1
  sbc r19, r2
  add r17, r0
  adc r18, r1
  adc r19, r2
  fmulsu r21, r22 ;((signed)bh * al) << 1
  sbc r19, r2
  add r17, r0
  adc r18, r1
  adc r19, r2
```

Words 1 (2 bytes)

Cycles 2

62. ICALL – Indirect Call to Subroutine

62.1. Description

Calls to a subroutine within the entire 4M (words) Program memory. The return address (to the instruction after the CALL) will be stored onto the Stack. See also RCALL. The Stack Pointer uses a post-decrement scheme during CALL.

This instruction is not available in all devices. Refer to the device specific instruction set summary.

Operation:	Comment:		
(i) $PC(15:0) \leftarrow Z(15:0)$	Devices with 16-bit PC, 128KB Program memory maximum.		
(ii) $PC(15:0) \leftarrow Z(15:0)$ $PC(21:16) \leftarrow 0$	Devices with 22-bit PC, 8MB Program memory maximum.		
Syntax:	Operands:	Program Counter:	Stack:
(i) ICALL	None	See Operation	$STACK \leftarrow PC + 1$ $SP \leftarrow SP - 2$ (2 bytes, 16 bits)
(ii) ICALL	None	See Operation	$STACK \leftarrow PC + 1$ $SP \leftarrow SP - 3$ (3 bytes, 22 bits)

16-bit Opcode:

1001	0101	0000	1001
------	------	------	------

62.2. Status Register (SREG) and Boolean Formula

I	T	H	S	V	N	Z	C
–	–	–	–	–	–	–	–

Example:

```
mov r30,r0 ; Set offset to call table
icall ; Call routine pointed to by r31:r30
```

Words	1 (2 bytes)
Cycles	3 devices with 16-bit PC 4 devices with 22-bit PC
Cycles XMEGA®	2 devices with 16-bit PC 3 devices with 22-bit PC

63. IJMP – Indirect Jump

63.1. Description

Indirect jump to the address pointed to by the Z (16 bits) Pointer Register in the Register File. The Z-pointer Register is 16 bits wide and allows jump within the lowest 64K words (128KB) section of Program memory.

This instruction is not available in all devices. Refer to the device specific instruction set summary.

Operation:	Comment:		
(i) $PC \leftarrow Z(15:0)$	Devices with 16-bit PC, 128KB Program memory maximum.		
(ii) $PC(15:0) \leftarrow Z(15:0)$ $PC(21:16) \leftarrow 0$	Devices with 22-bit PC, 8MB Program memory maximum.		
Syntax:	Operands:	Program Counter:	Stack:
(i), (ii) IJMP	None	See Operation	Not Affected

16-bit Opcode:

1001	0100	0000	1001
------	------	------	------

63.2. Status Register (SREG) and Boolean Formula

I	T	H	S	V	N	Z	C
–	–	–	–	–	–	–	–

Example:

```
mov r30,r0 ; Set offset to jump table
ijmp ; Jump to routine pointed to by r31:r30
```

Words 1 (2 bytes)

Cycles 2

64. IN - Load an I/O Location to Register

64.1. Description

Loads data from the I/O Space (Ports, Timers, Configuration Registers, etc.) into register Rd in the Register File.

Operation:

- (i) $Rd \leftarrow I/O(A)$

Syntax:

- (i) IN Rd,A

Operands:

- $0 \leq d \leq 31, 0 \leq A \leq 63$

Program Counter:

- $PC \leftarrow PC + 1$

16-bit Opcode:

1011	0AA <i>d</i>	<i>dddd</i>	AAAA
------	--------------	-------------	------

64.2. Status Register (SREG) and Boolean Formula

I	T	H	S	V	N	Z	C
–	–	–	–	–	–	–	–

Example:

```
in r25,$16 ; Read Port B
cpi r25,4 ; Compare read value to constant
breq exit ; Branch if r25=4
...
exit: nop ; Branch destination (do nothing)
```

Words 1 (2 bytes)

Cycles 1

65. INC – Increment

65.1. Description

Adds one -1- to the contents of register Rd and places the result in the destination register Rd.

The C Flag in SREG is not affected by the operation, thus allowing the INC instruction to be used on a loop counter in multiple-precision computations.

When operating on unsigned numbers, only BREQ and BRNE branches can be expected to perform consistently. When operating on two's complement values, all signed branches are available.

Operation:

$$(i) \quad R_d \leftarrow R_d + 1$$

Syntax:

(i) INC Rd

Operands:

$$0 \leq d \leq 31$$

Program Counter:

$$PC \leftarrow PC + 1$$

16-bit Opcode:

1001	010d	dddd	0011
------	------	------	------

65.2. Status Register and Boolean Formula

I	T	H	S	V	N	Z	C
–	–	–	↔	↔	↔	↔	–

S $N \oplus V$, for signed tests.

$$V \quad R_7 \cdot \overline{R_6} \cdot \overline{R_5} \cdot \overline{R_4} \cdot \overline{R_3} \cdot \overline{R_2} \cdot \overline{R_1} \cdot \overline{R_0}$$

Set if two's complement overflow resulted from the operation; cleared otherwise. Two's complement overflow occurs if and only if Rd was \$7F before the operation.

N R7

Set if MSB of the result is set; cleared otherwise.

$$Z \quad \overline{R_7} \cdot \overline{R_6} \cdot \overline{R_5} \cdot \overline{R_4} \cdot \overline{R_3} \cdot \overline{R_2} \cdot \overline{R_1} \cdot \overline{R_0}$$

Set if the result is \$00; cleared otherwise.

R (Result) equals Rd after the operation.

Example:

```
clr r22 ; clear r22
loop: inc r22 ; increment r22
...
cpi r22,$4F ; Compare r22 to $4f
brne loop ; Branch if not equal
nop ; Continue (do nothing)
```

Words

1 (2 bytes)

Cycles

1

66. JMP – Jump

66.1. Description

Jump to an address within the entire 4M (words) Program memory. See also RJMP.

This instruction is not available in all devices. Refer to the device specific instruction set summary.

Operation:

- (i) $PC \leftarrow k$

Syntax:

Operands:

Program Counter:

Stack:

- (i) JMP k

$0 \leq k < 4M$

$PC \leftarrow k$

Unchanged

32-bit Opcode:

1001	010k	kkkk	110k
kkkk	kkkk	kkkk	kkkk

66.2. Status Register (SREG) and Boolean Formula

I	T	H	S	V	N	Z	C
–	–	–	–	–	–	–	–

Example:

```
mov r1,r0 ; Copy r0 to r1
jmp farplc ; Unconditional jump
...
farplc: nop ; Jump destination (do nothing)
```

Words 2 (4 bytes)

Cycles 3

67. LAC – Load and Clear

67.1. Description

Load one byte indirect from data space to register and stores and clear the bits in data space specified by the register. The instruction can only be used towards internal SRAM.

The data location is pointed to by the Z (16 bits) Pointer Register in the Register File. Memory access is limited to the current data segment of 64KB. To access another data segment in devices with more than 64KB data space, the RAMPZ in register in the I/O area has to be changed.

The Z-pointer Register is left unchanged by the operation. This instruction is especially suited for clearing status bits stored in SRAM.

Operation:

$$(i) \quad (Z) \leftarrow (\$FF - Rd) \cdot (Z), Rd \leftarrow (Z)$$

Syntax:

$$(i) \quad LAC Z,Rd$$

Operands:

$$0 \leq d \leq 31$$

Program Counter:

$$PC \leftarrow PC + 1$$

16-bit Opcode:

1001	001r	rrrr	0110
------	------	------	------

67.2. Status Register (SREG) and Boolean Formula

I	T	H	S	V	N	Z	C
–	–	–	–	–	–	–	–

Words 1 (2 bytes)

Cycles 2

68. LAS – Load and Set

68.1. Description

Load one byte indirect from data space to register and set bits in data space specified by the register. The instruction can only be used towards internal SRAM.

The data location is pointed to by the Z (16 bits) Pointer Register in the Register File. Memory access is limited to the current data segment of 64KB. To access another data segment in devices with more than 64KB data space, the RAMPZ in register in the I/O area has to be changed.

The Z-pointer Register is left unchanged by the operation. This instruction is especially suited for setting status bits stored in SRAM.

Operation:

- (i) $(Z) \leftarrow Rd \vee (Z), Rd \leftarrow (Z)$

Syntax:

- (i) LAS Z,Rd

Operands:

- $0 \leq d \leq 31$

Program Counter:

- $PC \leftarrow PC + 1$

16-bit Opcode:

1001	001r	rrrr	0101
------	------	------	------

68.2. Status Register (SREG) and Boolean Formula

I	T	H	S	V	N	Z	C
–	–	–	–	–	–	–	–

Words 1 (2 bytes)

Cycles 2

69. LAT – Load and Toggle

69.1. Description

Load one byte indirect from data space to register and toggles bits in the data space specified by the register. The instruction can only be used towards SRAM.

The data location is pointed to by the Z (16 bits) Pointer Register in the Register File. Memory access is limited to the current data segment of 64KB. To access another data segment in devices with more than 64KB data space, the RAMPZ in register in the I/O area has to be changed.

The Z-pointer Register is left unchanged by the operation. This instruction is especially suited for changing status bits stored in SRAM.

Operation:

- (i) $(Z) \leftarrow Rd \oplus (Z), Rd \leftarrow (Z)$

Syntax:

- (i) LAT Z,Rd

Operands:

- $0 \leq d \leq 31$

Program Counter:

- $PC \leftarrow PC + 1$

16-bit Opcode:

1001	001r	rrrr	0111
------	------	------	------

69.2. Status Register (SREG) and Boolean Formula

I	T	H	S	V	N	Z	C
–	–	–	–	–	–	–	–

Words 1 (2 bytes)

Cycles 2

70. LD – Load Indirect from Data Space to Register using Index X

70.1. Description

Loads one byte indirect from the data space to a register. For parts with SRAM, the data space consists of the Register File, I/O memory, and internal SRAM (and external SRAM if applicable). For parts without SRAM, the data space consists of the Register File only. In some parts the Flash Memory has been mapped to the data space and can be read using this command. The EEPROM has a separate address space.

The data location is pointed to by the X (16 bits) Pointer Register in the Register File. Memory access is limited to the current data segment of 64KB. To access another data segment in devices with more than 64KB data space, the RAMPX in register in the I/O area has to be changed.

The X-pointer Register can either be left unchanged by the operation, or it can be post-incremented or pre-decremented. These features are especially suited for accessing arrays, tables, and Stack Pointer usage of the X-pointer Register. Note that only the low byte of the X-pointer is updated in devices with no more than 256 bytes data space. For such devices, the high byte of the pointer is not used by this instruction and can be used for other purposes. The RAMPX Register in the I/O area is updated in parts with more than 64KB data space or more than 64KB Program memory, and the increment/decrement is added to the entire 24-bit address on such devices.

Not all variants of this instruction is available in all devices. Refer to the device specific instruction set summary.

In the Reduced Core tinyAVR the LD instruction can be used to achieve the same operation as LPM since the program memory is mapped to the data memory space.

The result of these combinations is undefined:

LD r26, X+

LD r27, X+

LD r26, -X

LD r27, -X

Using the X-pointer:

Operation:		Comment:
(i) $Rd \leftarrow (X)$		X: Unchanged
(ii) $Rd \leftarrow (X) X \leftarrow X + 1$		X: Post incremented
(iii) $X \leftarrow X - 1 Rd \leftarrow (X)$		X: Pre decremented
Syntax:	Operands:	Program Counter:
(i) LD Rd, X	$0 \leq d \leq 31$	$PC \leftarrow PC + 1$
(ii) LD Rd, X+	$0 \leq d \leq 31$	$PC \leftarrow PC + 1$
(iii) LD Rd, -X	$0 \leq d \leq 31$	$PC \leftarrow PC + 1$

16-bit Opcode:

(i)	1001	000d	dddd	1100
(ii)	1001	000d	dddd	1101
(iii)	1001	000d	dddd	1110

70.2. Status Register (SREG) and Boolean Formula

I	T	H	S	V	N	Z	C
–	–	–	–	–	–	–	–

Example:

```
clr r27 ; Clear X high byte
ldi r26,$60 ; Set X low byte to $60
ld r0,X+ ; Load r0 with data space loc. $60(X post inc)
ld r1,X ; Load r1 with data space loc. $61
ldi r26,$63 ; Set X low byte to $63
ld r2,X ; Load r2 with data space loc. $63
ld r3,-X ; Load r3 with data space loc. $62(X pre dec)
```

Words 1 (2 bytes)

Cycles (i): 1⁽²⁾

(ii): 2

(iii): 3⁽²⁾

Cycles XMEGA (i): 1⁽¹⁾

(ii): 1⁽¹⁾

(iii): 2⁽¹⁾

- Note:** If the LD instruction is accessing internal SRAM, one extra cycle is inserted.
- Note:** LD instruction can load data from program memory since the flash is memory mapped. Loading data from the data memory takes one clock cycle, and loading from the program memory takes two clock cycles. But if an interrupt occur (before the last clock cycle) no additional clock cycles are necessary when loading from the program memory. Hence, the instruction takes only one clock cycle to execute.

LD instruction with pre-decrement can load data from program memory since the flash is memory mapped. Loading data from the data memory takes two clock cycles, and loading from the program memory takes three clock cycles. But if an interrupt occur (before the last clock cycle) no additional clock cycles are necessary when loading from the program memory. Hence, the instruction takes only one clock cycle to execute.

71. LD (LDD) – Load Indirect from Data Space to Register using Index Y

71.1. Description

Loads one byte indirect with or without displacement from the data space to a register. For parts with SRAM, the data space consists of the Register File, I/O memory, and internal SRAM (and external SRAM if applicable). For parts without SRAM, the data space consists of the Register File only. In some parts the Flash Memory has been mapped to the data space and can be read using this command. The EEPROM has a separate address space.

The data location is pointed to by the Y (16 bits) Pointer Register in the Register File. Memory access is limited to the current data segment of 64KB. To access another data segment in devices with more than 64KB data space, the RAMPY in register in the I/O area has to be changed.

The Y-pointer Register can either be left unchanged by the operation, or it can be post-incremented or pre-decremented. These features are especially suited for accessing arrays, tables, and Stack Pointer usage of the Y-pointer Register. Note that only the low byte of the Y-pointer is updated in devices with no more than 256 bytes data space. For such devices, the high byte of the pointer is not used by this instruction and can be used for other purposes. The RAMPY Register in the I/O area is updated in parts with more than 64KB data space or more than 64KB Program memory, and the increment/decrement/displacement is added to the entire 24-bit address on such devices.

Not all variants of this instruction is available in all devices. Refer to the device specific instruction set summary.

In the Reduced Core tinyAVR the LD instruction can be used to achieve the same operation as LPM since the program memory is mapped to the data memory space.

The result of these combinations is undefined:

LD r28, Y+

LD r29, Y+

LD r28, -Y

LD r29, -Y

Using the Y-pointer:

Operation:		Comment:
(i) $Rd \leftarrow (Y)$		Y: Unchanged
(ii) $Rd \leftarrow (Y), Y \leftarrow Y + 1$		Y: Post incremented
(iii) $Y \leftarrow Y - 1, Rd \leftarrow (Y)$		Y: Pre decremented
(iv) $Rd \leftarrow (Y+q)$		Y: Unchanged, q: Displacement
Syntax:	Operands:	Program Counter:
(i) LD Rd, Y	$0 \leq d \leq 31$	$PC \leftarrow PC + 1$
(ii) LD Rd, Y+	$0 \leq d \leq 31$	$PC \leftarrow PC + 1$

- | | | | |
|-------|-------------|--------------------------------------|------------------------|
| (iii) | LD Rd, -Y | $0 \leq d \leq 31$ | $PC \leftarrow PC + 1$ |
| (iv) | LDD Rd, Y+q | $0 \leq d \leq 31, 0 \leq q \leq 63$ | $PC \leftarrow PC + 1$ |

16-bit Opcode:

(i)	1000	000d	dddd	1000
(ii)	1001	000d	dddd	1001
(iii)	1001	000d	dddd	1010
(iv)	10q0	qq0d	dddd	1qqq

71.2. Status Register (SREG) and Boolean Formula

I	T	H	S	V	N	Z	C
–	–	–	–	–	–	–	–

Example:

```

clr r29 ; Clear Y high byte
ldi r28,$60 ; Set Y low byte to $60
ld r0,Y+ ; Load r0 with data space loc. $60(Y post inc)
ld r1,Y ; Load r1 with data space loc. $61
ldi r28,$63 ; Set Y low byte to $63
ld r2,Y ; Load r2 with data space loc. $63
ld r3,-Y ; Load r3 with data space loc. $62(Y pre dec)
ldd r4,Y+2 ; Load r4 with data space loc. $64

```

Words 1 (2 bytes)

Cycles (i): 1⁽²⁾

(ii): 2

(iii): 3⁽²⁾

Cycles XMEGA (i): 1⁽¹⁾

(ii): 1⁽¹⁾

(iii): 2⁽¹⁾

(iv): 2⁽¹⁾

- Note:** If the LD instruction is accessing internal SRAM, one extra cycle is inserted.
- Note:** LD instruction can load data from program memory since the flash is memory mapped. Loading data from the data memory takes one clock cycle, and loading from the program memory takes two clock cycles. But if an interrupt occur (before the last clock cycle) no additional clock cycles are necessary when loading from the program memory. Hence, the instruction takes only one clock cycle to execute.

LD instruction with pre-decrement can load data from program memory since the flash is memory mapped. Loading data from the data memory takes two clock cycles, and loading from the program memory takes three clock cycles. But if an interrupt occur (before the last clock cycle) no additional

clock cycles are necessary when loading from the program memory. Hence, the instruction takes only one clock cycle to execute.

72. LD (LDD) – Load Indirect From Data Space to Register using Index Z

72.1. Description

Loads one byte indirect with or without displacement from the data space to a register. For parts with SRAM, the data space consists of the Register File, I/O memory, and internal SRAM (and external SRAM if applicable). For parts without SRAM, the data space consists of the Register File only. In some parts the Flash Memory has been mapped to the data space and can be read using this command. The EEPROM has a separate address space.

The data location is pointed to by the Z (16 bits) Pointer Register in the Register File. Memory access is limited to the current data segment of 64KB. To access another data segment in devices with more than 64KB data space, the RAMPZ in register in the I/O area has to be changed.

The Z-pointer Register can either be left unchanged by the operation, or it can be post-incremented or pre-decremented. These features are especially suited for Stack Pointer usage of the Z-pointer Register, however, because the Z-pointer Register can be used for indirect subroutine calls, indirect jumps and table look-up, it is often more convenient to use the X- or Y-pointer as a dedicated Stack Pointer. Note that only the low byte of the Z-pointer is updated in devices with no more than 256 bytes data space. For such devices, the high byte of the pointer is not used by this instruction and can be used for other purposes. The RAMPZ Register in the I/O area is updated in parts with more than 64KB data space or more than 64KB Program memory, and the increment/decrement/displacement is added to the entire 24-bit address on such devices.

Not all variants of this instruction is available in all devices. Refer to the device specific instruction set summary.

In the tinyAVR reduced core the LD instruction can be used to achieve the same operation as LPM since the program memory is mapped to the data memory space.

For using the Z-pointer for table look-up in Program memory see the LPM and ELPM instructions.

The result of these combinations is undefined:

LD r30, Z+

LD r31, Z+

LD r30, -Z

LD r31, -Z

Using the Z-pointer:

Operation:	Comment:
(i) $Rd \leftarrow (Z)$	Z: Unchanged
(ii) $Rd \leftarrow (Z), Z \leftarrow Z + 1$	Z: Post incremented
(iii) $Z \leftarrow Z - 1, Rd \leftarrow (Z)$	Z: Pre decremented
(iv) $Rd \leftarrow (Z+q)$	Z: Unchanged, q: Displacement
Syntax:	Operands:
	Program Counter:

(i)	LD Rd, Z	$0 \leq d \leq 31$	$PC \leftarrow PC + 1$
(ii)	LD Rd, Z+	$0 \leq d \leq 31$	$PC \leftarrow PC + 1$
(iii)	LD Rd, -Z	$0 \leq d \leq 31$	$PC \leftarrow PC + 1$
(iv)	LDD Rd, Z+q	$0 \leq d \leq 31, 0 \leq q \leq 63$	$PC \leftarrow PC + 1$

16-bit Opcode:

(i)	1000	000d	dddd	0000
(ii)	1001	000d	dddd	0001
(iii)	1001	000d	dddd	0010
(iv)	10q0	qq0d	dddd	0qqq

72.2. Status Register (SREG) and Boolean Formula

I	T	H	S	V	N	Z	C
–	–	–	–	–	–	–	–

Example:

```

clr r31 ; Clear Z high byte
ldi r30,$60 ; Set Z low byte to $60
ld r0,Z+ ; Load r0 with data space loc. $60(Z post inc)
ld r1,Z ; Load r1 with data space loc. $61
ldi r30,$63 ; Set Z low byte to $63
ld r2,Z ; Load r2 with data space loc. $63
ld r3,-Z ; Load r3 with data space loc. $62(Z pre dec)
ldd r4,Z+2 ; Load r4 with data space loc. $64

```

Words	1 (2 bytes)
Cycles	(i): 1 ⁽²⁾ (ii): 2 (iii): 3 ⁽²⁾
Cycles XMEGA	(i): 1 ⁽¹⁾ (ii): 1 ⁽¹⁾ (iii): 2 ⁽¹⁾ (iv): 2 ⁽¹⁾

- Note:** If the LD instruction is accessing internal SRAM, one extra cycle is inserted.
- Note:** LD instruction can load data from program memory since the flash is memory mapped. Loading data from the data memory takes one clock cycle, and loading from the program memory takes two clock cycles. But if an interrupt occur (before the last clock cycle) no additional clock cycles are necessary when loading from the program memory. Hence, the instruction takes only one clock cycle to execute.

LD instruction with pre-decrement can load data from program memory since the flash is memory mapped. Loading data from the data memory takes two clock cycles, and loading from the program memory takes three clock cycles. But if an interrupt occur (before the last clock cycle) no additional clock cycles are necessary when loading from the program memory. Hence, the instruction takes only one clock cycle to execute.

73. LDI – Load Immediate

73.1. Description

Loads an 8-bit constant directly to register 16 to 31.

Operation:

- (i) $Rd \leftarrow K$

Syntax:

- (i) LDI Rd,K

Operands:

$16 \leq d \leq 31, 0 \leq K \leq 255$

Program Counter:

$PC \leftarrow PC + 1$

16-bit Opcode:

1110	KKKK	dddd	KKKK
------	------	------	------

73.2. Status Register (SREG) and Boolean Formula

I	T	H	S	V	N	Z	C
–	–	–	–	–	–	–	–

Example:

```
clr r31 ; Clear Z high byte
ldi r30,$F0 ; Set Z low byte to $F0
lpm ; Load constant from Program
; memory pointed to by Z
```

Words 1 (2 bytes)

Cycles 1

74. LDS – Load Direct from Data Space

74.1. Description

Loads one byte from the data space to a register. For parts with SRAM, the data space consists of the Register File, I/O memory, and internal SRAM (and external SRAM if applicable). For parts without SRAM, the data space consists of the register file only. The EEPROM has a separate address space.

A 16-bit address must be supplied. Memory access is limited to the current data segment of 64KB. The LDS instruction uses the RAMPD Register to access memory above 64KB. To access another data segment in devices with more than 64KB data space, the RAMPD in register in the I/O area has to be changed.

This instruction is not available in all devices. Refer to the device specific instruction set summary.

Operation:

- (i) $Rd \leftarrow (k)$

Syntax:

- (i) LDS Rd,k

Operands:

$0 \leq d \leq 31, 0 \leq k \leq 65535$

Program Counter:

$PC \leftarrow PC + 2$

32-bit Opcode:

1001	000d	dddd	0000
kkkk	kkkk	kkkk	kkkk

74.2. Status Register (SREG) and Boolean Formula

I	T	H	S	V	N	Z	C
–	–	–	–	–	–	–	–

Example:

```
lds r2,$FF00 ; Load r2 with the contents of data space location $FF00
add r2,r1 ; add r1 to r2
sts $FF00,r2 ; Write back
```

Words 2 (4 bytes)

Cycles 2

Cycles XMEGA 2 If the LDS instruction is accessing internal SRAM, one extra cycle is inserted

75. LDS (16-bit) – Load Direct from Data Space

75.1. Description

Loads one byte from the data space to a register. For parts with SRAM, the data space consists of the Register File, I/O memory, and internal SRAM (and external SRAM if applicable). For parts without SRAM, the data space consists of the register file only. In some parts the Flash memory has been mapped to the data space and can be read using this command. The EEPROM has a separate address space.

A 7-bit address must be supplied. The address given in the instruction is coded to a data space address as follows:

$$\text{ADDR}[7:0] = (\overline{\text{INST}}[8], \text{INST}[8], \text{INST}[10], \text{INST}[9], \text{INST}[3], \text{INST}[2], \text{INST}[1], \text{INST}[0])$$

Memory access is limited to the address range 0x40...0xbf.

This instruction is not available in all devices. Refer to the device specific instruction set summary.

Operation:

- (i) $Rd \leftarrow (k)$

Syntax:

- (i) LDS Rd,k

Operands:

$$16 \leq d \leq 31, 0 \leq k \leq 127$$

Program Counter:

$$PC \leftarrow PC + 1$$

16-bit Opcode:

1010	0kkk	dddd	kkkk
------	------	------	------

75.2. Status Register (SREG) and Boolean Formula

I	T	H	S	V	N	Z	C
–	–	–	–	–	–	–	–

Example:

```
lds r16,$00 ; Load r16 with the contents of data space location $00
add r16,r17 ; add r17 to r16
sts $00,r16 ; Write result to the same address it was fetched from
```

Words 1 (2 bytes)

Cycles 1

Note: Registers r0...r15 are remapped to r16. r31.

76. LPM – Load Program Memory

76.1. Description

Loads one byte pointed to by the Z-register into the destination register Rd. This instruction features a 100% space effective constant initialization or constant data fetch. The Program memory is organized in 16-bit words while the Z-pointer is a byte address. Thus, the least significant bit of the Z-pointer selects either low byte ($Z_{LSB} = 0$) or high byte ($Z_{LSB} = 1$). This instruction can address the first 64KB (32K words) of Program memory. The Z-pointer Register can either be left unchanged by the operation, or it can be incremented. The incrementation does not apply to the RAMPZ Register.

Devices with Self-Programming capability can use the LPM instruction to read the Fuse and Lock bit values. Refer to the device documentation for a detailed description.

The LPM instruction is not available in all devices. Refer to the device specific instruction set summary.

The result of these combinations is undefined:

LPM r30, Z+

LPM r31, Z+

	Operation:		Comment:
(i)	$R0 \leftarrow (Z)$		Z: Unchanged, R0 implied destination register
(ii)	$Rd \leftarrow (Z)$		Z: Unchanged
(iii)	$Rd \leftarrow (Z) \quad Z \leftarrow Z + 1$		Z: Post incremented
	Syntax:	Operands:	Program Counter:
(i)	LPM	None, R0 implied	$PC \leftarrow PC + 1$
(ii)	LPM Rd, Z	$0 \leq d \leq 31$	$PC \leftarrow PC + 1$
(iii)	LPM Rd, Z+	$0 \leq d \leq 31$	$PC \leftarrow PC + 1$

16-bit Opcode:

(i)	1001	0101	1100	1000
(ii)	1001	000d	dddd	0100
(iii)	1001	000d	dddd	0101

76.2. Status Register (SREG) and Boolean Formula

I	T	H	S	V	N	Z	C
–	–	–	–	–	–	–	–

Example:

```
ldi ZH, high(Table_1<<1) ; Initialize Z-pointer
ldi ZL, low(Table_1<<1)
lpm r16, Z ; Load constant from Program
; Memory pointed to by Z (r31:r30)
...
Table_1:
.dw 0x5876 ; 0x76 is addresses when ZLSB = 0
; 0x58 is addresses when ZLSB = 1
...
```

Words	1 (2 bytes)
Cycles	3

77. LSL – Logical Shift Left

77.1. Description

Shifts all bits in Rd one place to the left. Bit 0 is cleared. Bit 7 is loaded into the C Flag of the SREG. This operation effectively multiplies signed and unsigned values by two.

Operation:

(i)

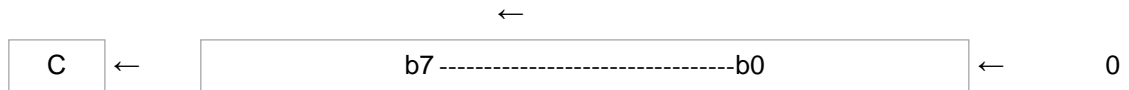

Syntax:

Operands:

Program Counter:

(i) LSL Rd

$0 \leq d \leq 31$

$PC \leftarrow PC + 1$

16-bit Opcode: (see ADD Rd,Rd)

0000	11dd	dddd	dddd
------	------	------	------

77.2. Status Register (SREG) and Boolean Formula

I	T	H	S	V	N	Z	C
–	–	↔	↔	↔	↔	↔	↔

H Rd3

S $N \oplus V$, for signed tests.

V $N \oplus C$, for N and C after the shift.

N R7

Set if MSB of the result is set; cleared otherwise.

Z $\overline{R7} \cdot \overline{R6} \cdot \overline{R5} \cdot \overline{R4} \cdot \overline{R3} \cdot \overline{R2} \cdot \overline{R1} \cdot \overline{R0}$

Set if the result is \$00; cleared otherwise.

C Rd7

Set if, before the shift, the MSB of Rd was set; cleared otherwise.

R (Result) equals Rd after the operation.

Example:

```
add r0,r4 ; Add r4 to r0
lsl r0 ; Multiply r0 by 2
```

Words

1 (2 bytes)

Cycles

1

78. LSR – Logical Shift Right

78.1. Description

Shifts all bits in Rd one place to the right. Bit 7 is cleared. Bit 0 is loaded into the C Flag of the SREG. This operation effectively divides an unsigned value by two. The C Flag can be used to round the result.

Operation:

(i)



Syntax:

Operands:

Program Counter:

(i) LSR Rd

$0 \leq d \leq 31$

$PC \leftarrow PC + 1$

16-bit Opcode:

1001	010d	dddd	0110
------	------	------	------

78.2. Status Register (SREG) and Boolean Formula

I	T	H	S	V	N	Z	C
–	–	–	↔	↔	0	↔	↔

S $N \oplus V$, for signed tests.

V $N \oplus C$, for N and C after the shift.

N 0

Z $\overline{R7} \cdot \overline{R6} \cdot \overline{R5} \cdot \overline{R4} \cdot \overline{R3} \cdot \overline{R2} \cdot \overline{R1} \cdot \overline{R0}$

Set if the result is \$00; cleared otherwise.

C Rd0

Set if, before the shift, the LSB of Rd was set; cleared otherwise.

R (Result) equals Rd after the operation.

Example:

```
add r0,r4 ; Add r4 to r0
lsr r0 ; Divide r0 by 2
```

Words

1 (2 bytes)

Cycles

1

79. MOV – Copy Register

79.1. Description

This instruction makes a copy of one register into another. The source register Rr is left unchanged, while the destination register Rd is loaded with a copy of Rr.

Operation:

- (i) $Rd \leftarrow Rr$

Syntax:

- (i) MOV Rd,Rr

Operands:

$0 \leq d \leq 31, 0 \leq r \leq 31$

Program Counter:

$PC \leftarrow PC + 1$

16-bit Opcode:

0010	11rd	dddd	rrrr
------	------	------	------

79.2. Status Register (SREG) and Boolean Formula

I	T	H	S	V	N	Z	C
–	–	–	–	–	–	–	–

Example:

```
mov r16,r0 ; Copy r0 to r16
call check ; Call subroutine
...
check: cpi r16,$11 ; Compare r16 to $11
...
ret ; Return from subroutine
```

Words 1 (2 bytes)

Cycles 1

80. MOVW – Copy Register Word

80.1. Description

This instruction makes a copy of one register pair into another register pair. The source register pair Rr + 1:Rr is left unchanged, while the destination register pair Rd+1:Rd is loaded with a copy of Rr + 1:Rr.

This instruction is not available in all devices. Refer to the device specific instruction set summary.

Operation:

- (i) $Rd+1:Rd \leftarrow Rr+1:Rr$

Syntax:

Operands:

Program Counter:

- (i) MOVW Rd+1:Rd,Rr+1:Rr $d \in \{0,2,\dots,30\}, r \in \{0,2,\dots,30\}$ $PC \leftarrow PC + 1$

16-bit Opcode:

0000	0001	dddd	rrrr
------	------	------	------

80.2. Status Register (SREG) and Boolean Formula

I	T	H	S	V	N	Z	C
–	–	–	–	–	–	–	–

Example:

```
mov w r17:16,r1:r0 ; Copy r1:r0 to r17:r16
call check ; Call subroutine
...
check: cpi r16,$11 ; Compare r16 to $11
...
cpi r17,$32 ; Compare r17 to $32
...
ret ; Return from subroutine
```

Words 1 (2 bytes)

Cycles 1

81. MUL – Multiply Unsigned

81.1. Description

This instruction performs 8-bit × 8-bit → 16-bit unsigned multiplication.

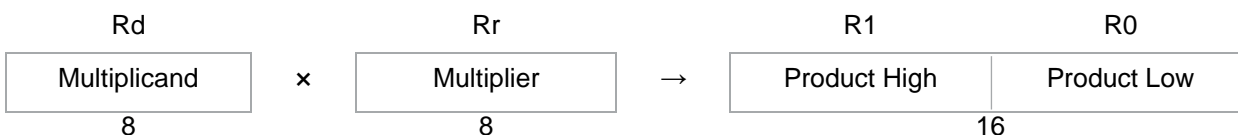

The multiplicand Rd and the multiplier Rr are two registers containing unsigned numbers. The 16-bit unsigned product is placed in R1 (high byte) and R0 (low byte). Note that if the multiplicand or the multiplier is selected from R0 or R1 the result will overwrite those after multiplication.

This instruction is not available in all devices. Refer to the device specific instruction set summary.

Operation:

- (i) R1:R0 ← Rd × Rr (unsigned ← unsigned × unsigned)

Syntax:

Operands:

Program Counter:

- (i) MUL Rd,Rr

0 ≤ d ≤ 31, 0 ≤ r ≤ 31

PC ← PC + 1

16-bit Opcode:

1001	11rd	dddd	rrrr
------	------	------	------

81.2. Status Register (SREG) and Boolean Formula

I	T	H	S	V	N	Z	C
–	–	–	–	–	–	↔	↔

C R15

Z $\overline{R15} \cdot \overline{R14} \cdot \overline{R13} \cdot \overline{R12} \cdot \overline{R11} \cdot \overline{R10} \cdot \overline{R9} \cdot \overline{R8} \cdot \overline{R7} \cdot \overline{R6} \cdot \overline{R5} \cdot \overline{R4} \cdot \overline{R3} \cdot \overline{R2} \cdot \overline{R1} \cdot \overline{R0}$

Set if the result is \$0000; cleared otherwise.

R (Result) equals R1,R0 after the operation.

Example:

```
mul r5,r4 ; Multiply unsigned r5 and r4
mov w r4,r0 ; Copy result back in r5:r4
```

Words 1 (2 bytes)

Cycles 1

82. MULS – Multiply Signed

82.1. Description

This instruction performs 8-bit × 8-bit → 16-bit signed multiplication.

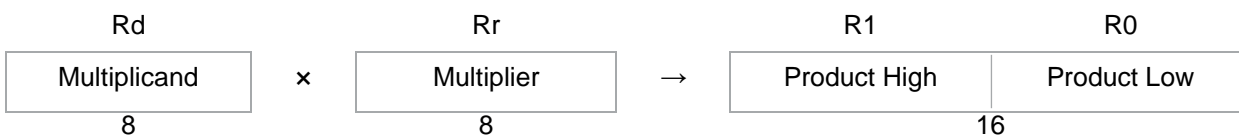

The multiplicand Rd and the multiplier Rr are two registers containing signed numbers. The 16-bit signed product is placed in R1 (high byte) and R0 (low byte).

This instruction is not available in all devices. Refer to the device specific instruction set summary.

Operation:

- (i) R1:R0 ← Rd × Rr (signed ← signed × signed)

Syntax:

Operands:

Program Counter:

- (i) MULS Rd,Rr

16 ≤ d ≤ 31, 16 ≤ r ≤ 31

PC ← PC + 1

16-bit Opcode:

0000	0010	dddd	rrrr
------	------	------	------

82.2. Status Register (SREG) and Boolean Formula

I	T	H	S	V	N	Z	C
–	–	–	–	–	–	↔	↔

C R15

Z $\overline{R15} \cdot \overline{R14} \cdot \overline{R13} \cdot \overline{R12} \cdot \overline{R11} \cdot \overline{R10} \cdot \overline{R9} \cdot \overline{R8} \cdot \overline{R7} \cdot \overline{R6} \cdot \overline{R5} \cdot \overline{R4} \cdot \overline{R3} \cdot \overline{R2} \cdot \overline{R1} \cdot \overline{R0}$

Set if the result is \$0000; cleared otherwise.

R (Result) equals R1,R0 after the operation.

Example:

```
muls r21,r20 ; Multiply signed r21 and r20
mov w r20,r0 ; Copy result back in r21:r20
```

Words 1 (2 bytes)

Cycles 1

83. MULSU – Multiply Signed with Unsigned

83.1. Description

This instruction performs 8-bit × 8-bit → 16-bit multiplication of a signed and an unsigned number.

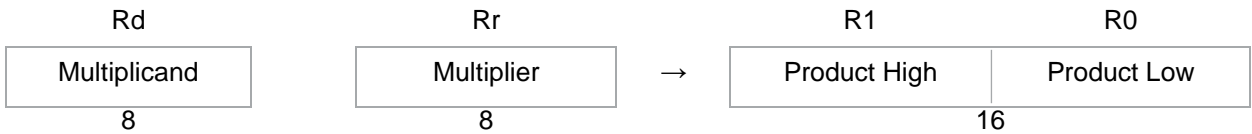

The multiplicand Rd and the multiplier Rr are two registers. The multiplicand Rd is a signed number, and the multiplier Rr is unsigned. The 16-bit signed product is placed in R1 (high byte) and R0 (low byte).

This instruction is not available in all devices. Refer to the device specific instruction set summary.

Operation:

- (i) R1:R0 ← Rd × Rr (signed ← signed × unsigned)

Syntax:

Operands:

Program Counter:

- (i) MULSU Rd,Rr

16 ≤ d ≤ 23, 16 ≤ r ≤ 23

PC ← PC + 1

16-bit Opcode:

0000	0011	0ddd	0rrr
------	------	------	------

83.2. Status Register (SREG) and Boolean Formula

I	T	H	S	V	N	Z	C
–	–	–	–	–	–	↔	↔

C R15

Z $\overline{R15} \cdot \overline{R14} \cdot \overline{R13} \cdot \overline{R12} \cdot \overline{R11} \cdot \overline{R10} \cdot \overline{R9} \cdot \overline{R8} \cdot \overline{R7} \cdot \overline{R6} \cdot \overline{R5} \cdot \overline{R4} \cdot \overline{R3} \cdot \overline{R2} \cdot \overline{R1} \cdot \overline{R0}$

Set if the result is \$0000; cleared otherwise.

R (Result) equals R1,R0 after the operation.

Example:

```

;*****
;* DESCRIPTION
;* Signed multiply of two 16-bit numbers with 32-bit result.
;* USAGE
;* r19:r18:r17:r16 = r23:r22 * r21:r20
;*****
muls16x16_32:
  clr r2
  muls r23, r21 ; (signed)ah * (signed)bh
  movw r19:r18, r1:r0
  mul r22, r20 ; al * bl
  movw r17:r16, r1:r0
  mulsu r23, r20 ; (signed)ah * bl

```

```
sbc r19, r2
add r17, r0
adc r18, r1
adc r19, r2
mulsu r21, r22 ; (signed)bh * al
sbc r19, r2
add r17, r0
adc r18, r1
adc r19, r2
ret
```

Words	1 (2 bytes)
Cycles	2

84. NEG – Two’s Complement

84.1. Description

Replaces the contents of register Rd with its two’s complement; the value \$80 is left unchanged.

Operation:

$$(i) \quad R_d \leftarrow \$00 - R_d$$

Syntax:

$$(i) \quad \text{NEG } R_d$$

Operands:

$$0 \leq d \leq 31$$

Program Counter:

$$PC \leftarrow PC + 1$$

16-bit Opcode:

1001	010d	dddd	0001
------	------	------	------

84.2. Status Register (SREG) and Boolean Formula

I	T	H	S	V	N	Z	C
–	–	↔	↔	↔	↔	↔	↔

$$\mathbf{H} \quad R_3 + \overline{R_d3}$$

Set if there was a borrow from bit 3; cleared otherwise.

$$\mathbf{S} \quad N \oplus V, \text{ for signed tests.}$$

$$\mathbf{V} \quad R_7 \cdot \overline{R_6} \cdot \overline{R_5} \cdot \overline{R_4} \cdot \overline{R_3} \cdot \overline{R_2} \cdot \overline{R_1} \cdot \overline{R_0}$$

Set if there is a two’s complement overflow from the implied subtraction from zero; cleared otherwise. A two’s complement overflow will occur if and only if the contents of the Register after operation (Result) is \$80.

$$\mathbf{N} \quad R_7$$

Set if MSB of the result is set; cleared otherwise.

$$\mathbf{Z} \quad \overline{R_7} \cdot \overline{R_6} \cdot \overline{R_5} \cdot \overline{R_4} \cdot \overline{R_3} \cdot \overline{R_2} \cdot \overline{R_1} \cdot \overline{R_0}$$

Set if the result is \$00; cleared otherwise.

$$\mathbf{C} \quad R_7 + R_6 + R_5 + R_4 + R_3 + R_2 + R_1 + R_0$$

Set if there is a borrow in the implied subtraction from zero; cleared otherwise. The C Flag will be set in all cases except when the contents of Register after operation is \$00.

R (Result) equals Rd after the operation.

Example:

```
sub r11,r0 ; Subtract r0 from r11
brpl positive ; Branch if result positive
```

```
neg r11 ; Take two's complement of r11  
positive: nop ; Branch destination (do nothing)
```

Words	1 (2 bytes)
Cycles	1

85. NOP – No Operation

85.1. Description

This instruction performs a single cycle No Operation.

Operation:

- (i) No

Syntax:

- (i) NOP

Operands:

None

Program Counter:

PC ← PC + 1

16-bit Opcode:

0000	0000	0000	0000
------	------	------	------

85.2. Status Register (SREG) and Boolean Formula

I	T	H	S	V	N	Z	C
–	–	–	–	–	–	–	–

Example:

```
clr r16 ; Clear r16
ser r17 ; Set r17
out $18,r16 ; Write zeros to Port B
nop ; Wait (do nothing)
out $18,r17 ; Write ones to Port B
```

Words 1 (2 bytes)

Cycles 1

86. OR – Logical OR

86.1. Description

Performs the logical OR between the contents of register Rd and register Rr, and places the result in the destination register Rd.

Operation:

(i) $Rd \leftarrow Rd \vee Rr$

Syntax:

Operands:

Program Counter:

(i) OR Rd,Rr

$0 \leq d \leq 31, 0 \leq r \leq 31$

$PC \leftarrow PC + 1$

16-bit Opcode:

0010	10rd	dddd	rrrr
------	------	------	------

86.2. Status Register (SREG) and Boolean Formula

I	T	H	S	V	N	Z	C
–	–	–	\Leftrightarrow	0	\Leftrightarrow	\Leftrightarrow	–

S $N \oplus V$, for signed tests.

V 0

Cleared.

N R7

Set if MSB of the result is set; cleared otherwise.

Z $\overline{R7} \cdot \overline{R6} \cdot \overline{R5} \cdot \overline{R4} \cdot \overline{R3} \cdot \overline{R2} \cdot \overline{R1} \cdot \overline{R0}$

Set if the result is \$00; cleared otherwise.

R (Result) equals Rd after the operation.

Example:

```
or r15,r16 ; Do bitwise or between registers
bst r15,6 ; Store bit 6 of r15 in T Flag
brts ok ; Branch if T Flag set
...
ok: nop ; Branch destination (do nothing)
```

Words 1 (2 bytes)

Cycles 1

87. ORI – Logical OR with Immediate

87.1. Description

Performs the logical OR between the contents of register Rd and a constant, and places the result in the destination register Rd.

Operation:

$$(i) \quad R_d \leftarrow R_d \vee K$$

Syntax:

$$(i) \quad \text{ORI } R_d, K$$

Operands:

$$16 \leq d \leq 31, 0 \leq K \leq 255$$

Program Counter:

$$PC \leftarrow PC + 1$$

16-bit Opcode:

0110	KKKK	dddd	KKKK
------	------	------	------

87.2. Status Register (SREG) and Boolean Formula

I	T	H	S	V	N	Z	C
–	–	–	↔	0	↔	↔	–

S $N \oplus V$, for signed tests.

V 0

Cleared.

N R7

Set if MSB of the result is set; cleared otherwise.

Z $\overline{R_7} \cdot \overline{R_6} \cdot \overline{R_5} \cdot \overline{R_4} \cdot \overline{R_3} \cdot \overline{R_2} \cdot \overline{R_1} \cdot \overline{R_0}$

Set if the result is \$00; cleared otherwise.

R (Result) equals Rd after the operation.

Example:

```
ori r16,$F0 ; Set high nibble of r16
ori r17,1 ; Set bit 0 of r17
```

Words 1 (2 bytes)

Cycles 1

88. OUT – Store Register to I/O Location

88.1. Description

Stores data from register Rr in the Register File to I/O Space (Ports, Timers, Configuration Registers, etc.).

Operation:

- (i) I/O(A) ← Rr

Syntax:

- (i) OUT A,Rr

Operands:

$0 \leq r \leq 31, 0 \leq A \leq 63$

Program Counter:

PC ← PC + 1

16-bit Opcode:

1011	1AAr	rrrr	AAAA
------	------	------	------

88.2. Status Register (SREG) and Boolean Formula

I	T	H	S	V	N	Z	C
–	–	–	–	–	–	–	–

Example:

```
clr r16 ; Clear r16
ser r17 ; Set r17
out $18,r16 ; Write zeros to Port B
nop ; Wait (do nothing)
out $18,r17 ; Write ones to Port B
```

Words 1 (2 bytes)

Cycles 1

89. POP – Pop Register from Stack

89.1. Description

This instruction loads register Rd with a byte from the STACK. The Stack Pointer is pre-incremented by 1 before the POP.

This instruction is not available in all devices. Refer to the device specific instruction set summary.

Operation:

(i) $Rd \leftarrow \text{STACK}$

Syntax:

Operands:

Program Counter:

Stack:

(i) POP Rd

$0 \leq d \leq 31$

$PC \leftarrow PC + 1$

$SP \leftarrow SP + 1$

16-bit Opcode:

1001	000d	dddd	1111
------	------	------	------

89.2. Status Register (SREG) and Boolean Formula

I	T	H	S	V	N	Z	C
–	–	–	–	–	–	–	–

Example:

```
call routine ; Call subroutine
...
routine: push r14 ; Save r14 on the Stack
push r13 ; Save r13 on the Stack
...
pop r13 ; Restore r13
pop r14 ; Restore r14
ret ; Return from subroutine
```

Words 1 (2 bytes)

Cycles 2

90. PUSH – Push Register on Stack

90.1. Description

This instruction stores the contents of register Rr on the STACK. The Stack Pointer is post-decremented by 1 after the PUSH.

This instruction is not available in all devices. Refer to the device specific instruction set summary.

Operation:

- (i) $STACK \leftarrow Rr$

Syntax:

Operands:

Program Counter:

Stack:

- (i) PUSH Rr

$0 \leq r \leq 31$

$PC \leftarrow PC + 1$

$SP \leftarrow SP - 1$

16-bit Opcode:

1001	001r	rrrr	1111
------	------	------	------

90.2. Status Register (SREG) and Boolean Formula

I	T	H	S	V	N	Z	C
–	–	–	–	–	–	–	–

Example:

```
call routine ; Call subroutine
...
routine: push r14 ; Save r14 on the Stack
push r13 ; Save r13 on the Stack
...
pop r13 ; Restore r13
pop r14 ; Restore r14
ret ; Return from subroutine
```

Words	1 (2 bytes)
Cycles	2
Cycles XMEGA	1

91. RCALL – Relative Call to Subroutine

91.1. Description

Relative call to an address within $PC - 2K + 1$ and $PC + 2K$ (words). The return address (the instruction after the RCALL) is stored onto the Stack. See also CALL. For AVR microcontrollers with Program memory not exceeding 4K words (8KB) this instruction can address the entire memory from every address location. The Stack Pointer uses a post-decrement scheme during RCALL.

Operation:	Comment:		
(i) $PC \leftarrow PC + k + 1$	Devices with 16-bit PC, 128KB Program memory maximum.		
(ii) $PC \leftarrow PC + k + 1$	Devices with 22-bit PC, 8MB Program memory maximum.		
Syntax:	Operands:	Program Counter:	Stack:
(i) RCALL k	$-2K \leq k < 2K$	$PC \leftarrow PC + k + 1$	STACK $\leftarrow PC + 1$ SP $\leftarrow SP - 2$ (2 bytes, 16 bits)
(ii) RCALL k	$-2K \leq k < 2K$	$PC \leftarrow PC + k + 1$	STACK $\leftarrow PC + 1$ SP $\leftarrow SP - 3$ (3 bytes, 22 bits)

16-bit Opcode:

1101	kkkk	kkkk	kkkk
------	------	------	------

91.2. Status Register (SREG) and Boolean Formula

I	T	H	S	V	N	Z	C
–	–	–	–	–	–	–	–

Example:

```
rcall routine ; Call subroutine
...
routine: push r14 ; Save r14 on the Stack
...
pop r14 ; Restore r14
ret ; Return from subroutine
```

Words	1 (2 bytes)
Cycles	3 devices with 16-bit PC 4 devices with 22-bit PC
Cycles XMEGA	2 devices with 16-bit PC 3 devices with 22-bit PC

92. RET – Return from Subroutine

92.1. Description

Returns from subroutine. The return address is loaded from the STACK. The Stack Pointer uses a pre-increment scheme during RET.

Operation:

Operation:	Comment:	Operands:	Program Counter:	Stack:
(i) PC(15:0) ← STACK	Devices with 16-bit PC, 128KB Program memory maximum.			
(ii) PC(21:0) ← STACK	Devices with 22-bit PC, 8MB Program memory maximum.			
Syntax:				
(i) RET	None		See Operation	SP ← SP + 2, (2 bytes, 16 bits)
(ii) RET	None		See Operation	SP ← SP + 3, (3 bytes, 22 bits)

16-bit Opcode:

1001	0101	0000	1000
------	------	------	------

92.2. Status Register (SREG) and Boolean Formula

I	T	H	S	V	N	Z	C
–	–	–	–	–	–	–	–

Example:

```

call routine ; Call subroutine
...
routine: push r14 ; Save r14 on the Stack
...
pop r14 ; Restore r14
ret ; Return from subroutine
    
```

Words	1 (2 bytes)
Cycles	4 devices with 16-bit PC 5 devices with 22-bit PC

93. RETI – Return from Interrupt

93.1. Description

Returns from interrupt. The return address is loaded from the STACK and the Global Interrupt Flag is set.

Note that the Status Register is not automatically stored when entering an interrupt routine, and it is not restored when returning from an interrupt routine. This must be handled by the application program. The Stack Pointer uses a pre-increment scheme during RETI.

Operation:	Comment:		
(i) PC(15:0) ← STACK	Devices with 16-bit PC, 128KB Program memory maximum.		
(ii) PC(21:0) ← STACK	Devices with 22-bit PC, 8MB Program memory maximum.		
Syntax:	Operands:	Program Counter:	Stack:
(i) RETI	None	See Operation	SP ← SP + 2 (2 bytes, 16 bits)
(ii) RETI	None	See Operation	SP ← SP + 3 (3 bytes, 22 bits)

16-bit Opcode:

1001	0101	0001	1000
------	------	------	------

93.2. Status Register (SREG) and Boolean Formula

I	T	H	S	V	N	Z	C
1	–	–	–	–	–	–	–

I 1
 The I Flag is set.

Example:

```

...
extint: push r0 ; Save r0 on the Stack
...
pop r0 ; Restore r0
reti ; Return and enable interrupts

```

Words 1 (2 bytes)
Cycles 4 devices with 16-bit PC
 5 devices with 22-bit PC

Note: RETI behaves differently in megaAVR and AVR XMEGA devices. In the megaAVR series of devices, the global interrupt flag is cleared by hardware once an interrupt occurs and this bit is set when RETI is executed. In the AVR XMEGA devices, RETI will not modify the global interrupt flag in SREG

since it is not cleared by hardware while entering ISR. This bit should be modified using SEI and CLI instructions when needed.

95. ROL – Rotate Left through Carry

95.1. Description

Shifts all bits in Rd one place to the left. The C Flag is shifted into bit 0 of Rd. Bit 7 is shifted into the C Flag. This operation, combined with LSL, effectively multiplies multi-byte signed and unsigned values by two.

Operation:



	Syntax:	Operands:	Program Counter:
(i)	ROL Rd	$0 \leq d \leq 31$	$PC \leftarrow PC + 1$

16-bit Opcode: (see ADC Rd,Rd)

0001	11dd	dddd	dddd
------	------	------	------

95.2. Status Register (SREG) and Boolean Formula

I	T	H	S	V	N	Z	C
–	–	↔	↔	↔	↔	↔	↔

H Rd3

S $N \oplus V$, for signed tests.

V $N \oplus C$, for N and C after the shift.

N R7

Set if MSB of the result is set; cleared otherwise.

Z $\overline{R7} \cdot \overline{R6} \cdot \overline{R5} \cdot \overline{R4} \cdot \overline{R3} \cdot \overline{R2} \cdot \overline{R1} \cdot \overline{R0}$

Set if the result is \$00; cleared otherwise.

C Rd7

Set if, before the shift, the MSB of Rd was set; cleared otherwise.

R (Result) equals Rd after the operation.

Example:

```
lsl r18 ; Multiply r19:r18 by two
rol r19 ; r19:r18 is a signed or unsigned two-byte integer
brcs oneenc ; Branch if carry set
...
oneenc: nop ; Branch destination (do nothing)
```

Words

1 (2 bytes)

Cycles

1

```
zeroenc1: nop ; Branch destination (do nothing)
...
zeroenc1: nop ; Branch destination (do nothing)
```

Words	1 (2 bytes)
Cycles	1

97. SBC – Subtract with Carry

97.1. Description

Subtracts two registers and subtracts with the C Flag, and places the result in the destination register Rd.

Operation:

$$(i) \quad R_d \leftarrow R_d - R_r - C$$

Syntax:

$$(i) \quad \text{SBC } R_d, R_r$$

Operands:

$$0 \leq d \leq 31, 0 \leq r \leq 31$$

Program Counter:

$$PC \leftarrow PC + 1$$

16-bit Opcode:

0000	10rd	dddd	rrrr
------	------	------	------

97.2. Status Register (SREG) and Boolean Formula

I	T	H	S	V	N	Z	C
–	–	↔	↔	↔	↔	↔	↔

$$\mathbf{H} \quad \overline{Rd3} \cdot Rr3 + Rr3 \cdot R3 + R3 \cdot \overline{Rd3}$$

Set if there was a borrow from bit 3; cleared otherwise.

$$\mathbf{S} \quad N \oplus V, \text{ for signed tests.}$$

$$\mathbf{V} \quad Rd7 \cdot \overline{Rr7} \cdot \overline{R7} + \overline{Rd7} \cdot Rr7 \cdot R7$$

Set if two's complement overflow resulted from the operation; cleared otherwise.

$$\mathbf{N} \quad R7$$

Set if MSB of the result is set; cleared otherwise.

$$\mathbf{Z} \quad \overline{R7} \cdot \overline{R6} \cdot \overline{R5} \cdot \overline{R4} \cdot \overline{R3} \cdot \overline{R2} \cdot \overline{R1} \cdot \overline{R0} \cdot Z$$

Previous value remains unchanged when the result is zero; cleared otherwise.

$$\mathbf{C} \quad \overline{Rd7} \cdot Rr7 + Rr7 \cdot R7 + R7 \cdot \overline{Rd7}$$

Set if the absolute value of the contents of Rr plus previous carry is larger than the absolute value of the Rd; cleared otherwise.

R (Result) equals Rd after the operation.

Example:

```
; Subtract r1:r0 from r3:r2
sub r2,r0 ; Subtract low byte
sbc r3,r1 ; Subtract with carry high byte
```

Words

1 (2 bytes)

Cycles

1

98. SBCI – Subtract Immediate with Carry SBI – Set Bit in I/O Register

98.1. Description

Subtracts a constant from a register and subtracts with the C Flag, and places the result in the destination register Rd.

Operation:

$$(i) \quad R_d \leftarrow R_d - K - C$$

Syntax:

$$(i) \quad \text{SBCI } R_d, K$$

Operands:

$$16 \leq d \leq 31, 0 \leq K \leq 255$$

Program Counter:

$$PC \leftarrow PC + 1$$

16-bit Opcode:

0100	KKKK	dddd	KKKK
------	------	------	------

98.2. Status Register (SREG) and Boolean Formula

I	T	H	S	V	N	Z	C
–	–	↔	↔	↔	↔	↔	↔

$$\mathbf{H} \quad \overline{R_{d3}} \cdot K_3 + K_3 \cdot R_3 + R_3 \cdot \overline{R_{d3}}$$

Set if there was a borrow from bit 3; cleared otherwise.

$$\mathbf{S} \quad N \oplus V, \text{ for signed tests.}$$

$$\mathbf{V} \quad R_{d7} \cdot \overline{K_7} \cdot \overline{R_7} + \overline{R_{d7}} \cdot K_7 \cdot R_7$$

Set if two's complement overflow resulted from the operation; cleared otherwise.

$$\mathbf{N} \quad R_7$$

Set if MSB of the result is set; cleared otherwise.

$$\mathbf{Z} \quad \overline{R_7} \cdot \overline{R_6} \cdot \overline{R_5} \cdot \overline{R_4} \cdot \overline{R_3} \cdot \overline{R_2} \cdot \overline{R_1} \cdot \overline{R_0} \cdot Z$$

Previous value remains unchanged when the result is zero; cleared otherwise.

$$\mathbf{C} \quad \overline{R_{d7}} \cdot K_7 + K_7 \cdot R_7 + R_7 \cdot \overline{R_{d7}}$$

Set if the absolute value of the constant plus previous carry is larger than the absolute value of Rd; cleared otherwise.

R (Result) equals Rd after the operation.

Example:

```
; Subtract $4F23 from r17:r16
subi r16,$23 ; Subtract low byte
sbci r17,$4F ; Subtract with carry high byte
```

Words

1 (2 bytes)

Cycles

1

99. SBI – Set Bit in I/O Register

99.1. Description

Sets a specified bit in an I/O Register. This instruction operates on the lower 32 I/O Registers – addresses 0-31.

Operation:

(i) $I/O(A,b) \leftarrow 1$

Syntax:

(i) SBI A,b

Operands:

$0 \leq A \leq 31, 0 \leq b \leq 7$

Program Counter:

$PC \leftarrow PC + 1$

16-bit Opcode:

1001	1010	AAAA	Abbb
------	------	------	------

99.2. Status Register (SREG) and Boolean Formula

I	T	H	S	V	N	Z	C
–	–	–	–	–	–	–	–

Example:

```
out $1E,r0 ; Write EEPROM address
sbi $1C,0 ; Set read bit in EECR
in r1,$1D ; Read EEPROM data
```

Words	1 (2 bytes)
Cycles	2
Cycles XMEGA	1
Cycles Reduced Core tinyAVR	1

100. SBIC – Skip if Bit in I/O Register is Cleared

100.1. Description

This instruction tests a single bit in an I/O Register and skips the next instruction if the bit is cleared. This instruction operates on the lower 32 I/O Registers – addresses 0-31.

Operation:

- (i) If $I/O(A,b) = 0$ then $PC \leftarrow PC + 2$ (or 3) else $PC \leftarrow PC + 1$

Syntax:

Operands:

Program Counter:

- (i) SBIC A,b

$0 \leq A \leq 31, 0 \leq b \leq 7$

$PC \leftarrow PC + 1$, Condition false - no skip

$PC \leftarrow PC + 2$, Skip a one word instruction

$PC \leftarrow PC + 3$, Skip a two word instruction

16-bit Opcode:

1001	1001	AAAA	Abbb
------	------	------	------

100.2. Status Register (SREG) and Boolean Formula

I	T	H	S	V	N	Z	C
–	–	–	–	–	–	–	–

Example:

```
e2wait: sbic $1C,1 ; Skip next inst. if EWE cleared
rjmp e2wait ; EEPROM write not finished
nop ; Continue (do nothing)
```

Words 1 (2 bytes)

Cycles 1 if condition is false (no skip)

2 if condition is true (skip is executed) and the instruction skipped is 1 word

3 if condition is true (skip is executed) and the instruction skipped is 2 words

Cycles XMEGA 2 if condition is false (no skip)

3 if condition is true (skip is executed) and the instruction skipped is 1 word

4 if condition is true (skip is executed) and the instruction skipped is 2 words

101. SBIS – Skip if Bit in I/O Register is Set

101.1. Description

This instruction tests a single bit in an I/O Register and skips the next instruction if the bit is set. This instruction operates on the lower 32 I/O Registers – addresses 0-31.

Operation:

- (i) If $I/O(A,b) = 1$ then $PC \leftarrow PC + 2$ (or 3) else $PC \leftarrow PC + 1$

Syntax:

Operands:

Program Counter:

- (i) SBIS A,b

$0 \leq A \leq 31, 0 \leq b \leq 7$

$PC \leftarrow PC + 1$, Condition false - no skip

$PC \leftarrow PC + 2$, Skip a one word instruction

$PC \leftarrow PC + 3$, Skip a two word instruction

16-bit Opcode:

1001	1011	AAAA	Abbb
------	------	------	------

101.2. Status Register (SREG) and Boolean Formula

I	T	H	S	V	N	Z	C
–	–	–	–	–	–	–	–

Example:

```
waitset: sbis $10,0 ; Skip next inst. if bit 0 in Port D set
         rjmp waitset ; Bit not set
         nop ; Continue (do nothing)
```

Words 1 (2 bytes)

Cycles 1 if condition is false (no skip)

2 if condition is true (skip is executed) and the instruction skipped is 1 word

3 if condition is true (skip is executed) and the instruction skipped is 2 words

Cycles XMEGA 2 if condition is false (no skip)

3 if condition is true (skip is executed) and the instruction skipped is 1 word

4 if condition is true (skip is executed) and the instruction skipped is 2 words

102. SBIW – Subtract Immediate from Word

102.1. Description

Subtracts an immediate value (0-63) from a register pair and places the result in the register pair. This instruction operates on the upper four register pairs, and is well suited for operations on the Pointer Registers.

This instruction is not available in all devices. Refer to the device specific instruction set summary.

Operation:

$$(i) \quad R_{d+1}:R_d \leftarrow R_{d+1}:R_d - K$$

Syntax:

Operands:

Program Counter:

$$(i) \quad \text{SBIW } R_{d+1}:R_d, K \quad d \in \{24, 26, 28, 30\}, 0 \leq K \leq 63 \quad PC \leftarrow PC + 1$$

16-bit Opcode:

1001	0111	KKdd	KKKK
------	------	------	------

102.2. Status Register (SREG) and Boolean Formula

I	T	H	S	V	N	Z	C
–	–	–	↔	↔	↔	↔	↔

S $N \oplus V$, for signed tests.

$$\mathbf{V} \quad R_{15} \cdot \overline{R_{dh7}}$$

Set if two's complement overflow resulted from the operation; cleared otherwise.

$$\mathbf{N} \quad R_{15}$$

Set if MSB of the result is set; cleared otherwise.

$$\mathbf{Z} \quad \overline{R_{15}} \cdot \overline{R_{14}} \cdot \overline{R_{13}} \cdot \overline{R_{12}} \cdot \overline{R_{11}} \cdot \overline{R_{10}} \cdot \overline{R_9} \cdot \overline{R_{8R7}} \cdot \overline{R_6} \cdot \overline{R_5} \cdot \overline{R_4} \cdot \overline{R_3} \cdot \overline{R_2} \cdot \overline{R_1} \cdot \overline{R_0}$$

Set if the result is \$0000; cleared otherwise.

$$\mathbf{C} \quad R_{15} \cdot \overline{R_{dh7}}$$

Set if the absolute value of K is larger than the absolute value of Rd; cleared otherwise.

R (Result) equals Rdh:Rdl after the operation (Rdh7-Rdh0 = R15-R8, Rdl7-Rdl0=R7-R0).

Example:

```
sbiw r25:r24,1 ; Subtract 1 from r25:r24
sbiw YH:YL,63 ; Subtract 63 from the Y-pointer(r29:r28)
```

Words

1 (2 bytes)

103. SBR – Set Bits in Register

103.1. Description

Sets specified bits in register Rd. Performs the logical ORI between the contents of register Rd and a constant mask K, and places the result in the destination register Rd.

Operation:

$$(i) \quad R_d \leftarrow R_d \vee K$$

Syntax:

$$(i) \quad \text{SBR } R_d, K$$

Operands:

$$16 \leq d \leq 31, 0 \leq K \leq 255$$

Program Counter:

$$PC \leftarrow PC + 1$$

16-bit Opcode:

0110	KKKK	dddd	KKKK
------	------	------	------

103.2. Status Register (SREG) and Boolean Formula

I	T	H	S	V	N	Z	C
–	–	–	↔	0	↔	↔	–

S $N \oplus V$, for signed tests.

V 0

Cleared.

N R7

Set if MSB of the result is set; cleared otherwise.

Z $\overline{R7} \cdot \overline{R6} \cdot \overline{R5} \cdot \overline{R4} \cdot \overline{R3} \cdot \overline{R2} \cdot \overline{R1} \cdot \overline{R0}$

Set if the result is \$00; cleared otherwise.

R (Result) equals Rd after the operation.

Example:

```
sbr r16,3 ; Set bits 0 and 1 in r16
sbr r17,$F0 ; Set 4 MSB in r17
```

Words 1 (2 bytes)

Cycles 1

104. SBRC – Skip if Bit in Register is Cleared

104.1. Description

This instruction tests a single bit in a register and skips the next instruction if the bit is cleared.

Operation:

Operation:

- (i) If $Rr(b) = 0$ then $PC \leftarrow PC + 2$ (or 3) else $PC \leftarrow PC + 1$

Syntax:

Operands:

Program Counter:

- (i) SBRC Rr,b

$0 \leq r \leq 31, 0 \leq b \leq 7$

$PC \leftarrow PC + 1$, Condition false - no skip

$PC \leftarrow PC + 2$, Skip a one word instruction

$PC \leftarrow PC + 3$, Skip a two word instruction

16-bit Opcode:

1111	110r	rrrr	0bbb
------	------	------	------

104.2. Status Register (SREG) and Boolean Formula

I	T	H	S	V	N	Z	C
–	–	–	–	–	–	–	–

Example:

```
sub r0,r1 ; Subtract r1 from r0
sbrc r0,7 ; Skip if bit 7 in r0 cleared
sub r0,r1 ; Only executed if bit 7 in r0 not cleared
nop ; Continue (do nothing)
```

Words 1 (2 bytes)

Cycles 1 if condition is false (no skip)

2 if condition is true (skip is executed) and the instruction skipped is 1 word

3 if condition is true (skip is executed) and the instruction skipped is 2 words

105. SBRS – Skip if Bit in Register is Set

105.1. Description

This instruction tests a single bit in a register and skips the next instruction if the bit is set.

Operation:

- (i) If $Rr(b) = 1$ then $PC \leftarrow PC + 2$ (or 3) else $PC \leftarrow PC + 1$

Syntax:

Operands:

Program Counter:

- (i) SBRS Rr,b

$0 \leq r \leq 31, 0 \leq b \leq 7$

$PC \leftarrow PC + 1$, Condition false - no skip

$PC \leftarrow PC + 2$, Skip a one word instruction

$PC \leftarrow PC + 3$, Skip a two word instruction

16-bit Opcode:

1111	111r	rrrr	0bbb
------	------	------	------

105.2. Status Register (SREG) and Boolean Formula

I	T	H	S	V	N	Z	C
–	–	–	–	–	–	–	–

Example:

```
sub r0,r1 ; Subtract r1 from r0
sbrs r0,7 ; Skip if bit 7 in r0 set
neg r0 ; Only executed if bit 7 in r0 not set
nop ; Continue (do nothing)
```

Words 1 (2 bytes)

Cycles 1 if condition is false (no skip)

2 if condition is true (skip is executed) and the instruction skipped is 1 word

3 if condition is true (skip is executed) and the instruction skipped is 2 words

110. SER – Set all Bits in Register

110.1. Description

Loads \$FF directly to register Rd.

Operation:

(i) $Rd \leftarrow \$FF$

Syntax:

(i) SER Rd

Operands:

$16 \leq d \leq 31$

Program Counter:

$PC \leftarrow PC + 1$

16-bit Opcode:

1110	1111	dddd	1111
------	------	------	------

110.2. Status Register (SREG) and Boolean Formula

I	T	H	S	V	N	Z	C
–	–	–	–	–	–	–	–

Example:

```
clr r16 ; Clear r16
ser r17 ; Set r17
out $18,r16 ; Write zeros to Port B
nop ; Delay (do nothing)
out $18,r17 ; Write ones to Port B
```

Words 1 (2 bytes)

Cycles 1

113. SEV – Set Overflow Flag

113.1. Description

Sets the Overflow Flag (V) in SREG (Status Register).

Operation:

- (i) $V \leftarrow 1$

Syntax:

Operands:

Program Counter:

- (i) SEV

None

$PC \leftarrow PC + 1$

16-bit Opcode:

1001	0100	0011	1000
------	------	------	------

113.2. Status Register (SREG) and Boolean Formula

I	T	H	S	V	N	Z	C
–	–	–	–	1	–	–	–

V

V: 1

Overflow Flag set.

Example:

```
add r2,r19 ; Add r19 to r2
sev ; Set Overflow Flag
```

Words

1 (2 bytes)

Cycles

1

115. SLEEP

115.1. Description

This instruction sets the circuit in sleep mode defined by the MCU Control Register.

Operation:

- (i) Refer to the device documentation for detailed description of SLEEP usage.

Syntax:

Operands:

Program Counter:

- (i) SLEEP

None

PC ← PC + 1

16-bit Opcode:

1001	0101	1000	1000
------	------	------	------

115.2. Status Register (SREG) and Boolean Formula

I	T	H	S	V	N	Z	C
–	–	–	–	–	–	–	–

Example:

```
mov r0,r11 ; Copy r11 to r0
ldi r16,(1<<SE) ; Enable sleep mode
out MCUCR, r16
sleep ; Put MCU in sleep mode
```

Words

1 (2 bytes)

Cycles

1

116. SPM – Store Program Memory

116.1. Description

SPM can be used to erase a page in the Program memory, to write a page in the Program memory (that is already erased), and to set Boot Loader Lock bits. In some devices, the Program memory can be written one word at a time, in other devices an entire page can be programmed simultaneously after first filling a temporary page buffer. In all cases, the Program memory must be erased one page at a time. When erasing the Program memory, the RAMPZ and Z-register are used as page address. When writing the Program memory, the RAMPZ and Z-register are used as page or word address, and the R1:R0 register pair is used as data⁽¹⁾. When setting the Boot Loader Lock bits, the R1:R0 register pair is used as data. Refer to the device documentation for detailed description of SPM usage. This instruction can address the entire Program memory.

The SPM instruction is not available in all devices. Refer to the device specific instruction set summary.

Note: 1. R1 determines the instruction high byte, and R0 determines the instruction low byte.

Operation:

- (i) (RAMPZ:Z) ← \$ffff Erase Program memory page
- (ii) (RAMPZ:Z) ← R1:R0 Write Program memory word
- (iii) (RAMPZ:Z) ← R1:R0 Write temporary page buffer
- (iv) (RAMPZ:Z) ← TEMP Write temporary page buffer to Program memory
- (v) BLBITS ← R1:R0 Set Boot Loader Lock bits

Syntax:

Operands:

Program Counter:

- (i)-(v) SPM Z+ PC ← PC + 1

16-bit Opcode:

1001	0101	1110	1000
------	------	------	------

116.2. Status Register (SREG) and Boolean Formula

I	T	H	S	V	N	Z	C
–	–	–	–	–	–	–	–

Example:

```

;This example shows SPM write of one page for devices with page write
;- the routine writes one page of data from RAM to Flash
; the first data location in RAM is pointed to by the Y-pointer
; the first data location in Flash is pointed to by the Z-pointer
;- error handling is not included
;- the routine must be placed inside the boot space
; (at least the do_spm sub routine)
;- registers used: r0, r1, temp1, temp2, looplo, loophi, spmcval

```

```

; (templ, temp2, looplo, loophi, spmcrcval must be defined by the user)
; storing and restoring of registers is not included in the routine
; register usage can be optimized at the expense of code size

.equ PAGESIZEB = PAGESIZE*2 ;PAGESIZEB is page size in BYTES, not words
.org SMALLBOOTSTART
write_page:
;page erase
ldi spmcrcval, (1<<PGRS) + (1<<SPMEN)
call do_spm
;transfer data from RAM to Flash page buffer
ldi looplo, low(PAGESIZEB) ;init loop variable
ldi loophi, high(PAGESIZEB) ;not required for PAGESIZEB<=256
wrloop: ld r0, Y+
ld r1, Y+
ldi spmcrcval, (1<<SPMEN)
call do_spm
adiw ZH:ZL, 2
sbiw loophi:looplo, 2 ;use subi for PAGESIZEB<=256
brne wrloop

;execute page write
subi ZL, low(PAGESIZEB);restore pointer
sbci ZH, high(PAGESIZEB) ;not required for PAGESIZEB<=256
ldi spmcrcval, (1<<PGWRT) + (1<<SPMEN)
call do_spm

;read back and check, optional
ldi looplo, low(PAGESIZEB) ;init loop variable
ldi loophi, high(PAGESIZEB) ;not required for PAGESIZEB<=256
subi YL, low(PAGESIZEB) ;restore pointer
sbci YH, high(PAGESIZEB)
rdloop: lpm r0, Z+
ld r1, Y+
cpse r0, r1
jmp error
sbiw loophi:looplo, 2 ;use subi for PAGESIZEB<=256
brne rdloop

;return
ret

do_spm:
;input: spmcrcval determines SPM action
;disable interrupts if enabled, store status
in temp2, SREG
cli
;check for previous SPM complete
wait: in templ, SPMCR
sbrc templ, SPMEN
rjmp wait
;SPM timed sequence
out SPMCR, spmcrcval
spm
;restore SREG (to enable interrupts if originally enabled)
out SREG, temp2
ret

```

Words	1 (2 bytes)
Cycles	Depends on the operation

117. SPM #2 – Store Program Memory

117.1. Description

SPM can be used to erase a page in the Program memory and to write a page in the Program memory (that is already erased). An entire page can be programmed simultaneously after first filling a temporary page buffer. The Program memory must be erased one page at a time. When erasing the Program memory, the RAMPZ and Z-register are used as page address. When writing the Program memory, the RAMPZ and Z-register are used as page or word address, and the R1:R0 register pair is used as data⁽¹⁾.

Refer to the device documentation for detailed description of SPM usage. This instruction can address the entire Program memory.

Note: 1. R1 determines the instruction high byte, and R0 determines the instruction low byte.

Operation:

- (i) (RAMPZ:Z) ← \$ffff Erase Program memory page
- (ii) (RAMPZ:Z) ← R1:R0 Load Page Buffer
- (iii) (RAMPZ:Z) ← BUFFER Write Page Buffer to Program memory
- (iv) (RAMPZ:Z) ← \$fff, Z ← Z + 2 Erase Program memory page, Z post incremented
- (v) BLBITS ← R1:R0, Z ← Z + 2 Load Page Buffer, Z post incremented
- (vi) (RAMPZ:Z) ← BUFFER, Z ← Z + 2 Write Page Buffer to Program memory, Z post incremented

Syntax:

Operands:

Program Counter:

- (i)-(iii) SPM None PC ← PC + 1
- (iv)-(vi) SPM Z+ None PC ← PC + 1

16-bit Opcode:

(i)-(iii)	1001	0101	1110	1000
(iv)-(vi)	1001	0101	1111	1000

117.2. Status Register (SREG) and Boolean Formula

I	T	H	S	V	N	Z	C
–	–	–	–	–	–	–	–

Words

1 (2 bytes)

Cycles

Depends on the operation

118. ST – Store Indirect From Register to Data Space using Index X

118.1. Description

Stores one byte indirect from a register to data space. For parts with SRAM, the data space consists of the Register File, I/O memory, and internal SRAM (and external SRAM if applicable). For parts without SRAM, the data space consists of the Register File only. The EEPROM has a separate address space.

The data location is pointed to by the X (16 bits) Pointer Register in the Register File. Memory access is limited to the current data segment of 64KB. To access another data segment in devices with more than 64KB data space, the RAMPX in register in the I/O area has to be changed.

The X-pointer Register can either be left unchanged by the operation, or it can be post-incremented or pre-decremented. These features are especially suited for accessing arrays, tables, and Stack Pointer usage of the X-pointer Register. Note that only the low byte of the X-pointer is updated in devices with no more than 256 bytes data space. For such devices, the high byte of the pointer is not used by this instruction and can be used for other purposes. The RAMPX Register in the I/O area is updated in parts with more than 64KB data space or more than 64KB Program memory, and the increment/ decrement is added to the entire 24-bit address on such devices.

Not all variants of this instruction is available in all devices. Refer to the device specific instruction set summary.

The result of these combinations is undefined:

ST X+, r26

ST X+, r27

ST -X, r26

ST -X, r27

Using the X-pointer:

Operation:		Comment:
(i) $(X) \leftarrow Rr$		X: Unchanged
(ii) $(X) \leftarrow Rr, X \leftarrow X+1$		X: Post incremented
(iii) $X \leftarrow X - 1, (X) \leftarrow Rr$		X: Pre decremented
Syntax:	Operands:	Program Counter:
(i) ST X, Rr	$0 \leq r \leq 31$	$PC \leftarrow PC + 1$
(ii) ST X+, Rr	$0 \leq r \leq 31$	$PC \leftarrow PC + 1$
(iii) ST -X, Rr	$0 \leq r \leq 31$	$PC \leftarrow PC + 1$

16-bit Opcode:

(i)	1001	001r	rrrr	1100
(ii)	1001	001r	rrrr	1101
(iii)	1001	001r	rrrr	1110

118.2. Status Register (SREG) and Boolean Formula

I	T	H	S	V	N	Z	C
–	–	–	–	–	–	–	–

Example:

```

clr r27 ; Clear X high byte
ldi r26,$60 ; Set X low byte to $60
st X+,r0 ; Store r0 in data space loc. $60(X post inc)
st X,r1 ; Store r1 in data space loc. $61
ldi r26,$63 ; Set X low byte to $63
st X,r2 ; Store r2 in data space loc. $63
st -X,r3 ; Store r3 in data space loc. $62(X pre dec)

```

Words	1 (2 bytes)
Cycles	2
Cycles XMEGA	(i) 1 (ii) 1 (iii) 2
Cycles Reduced Core tinyAVR	(i) 1 (ii) 1 (iii) 2

119. ST (STD) – Store Indirect From Register to Data Space using Index Y

119.1. Description

Stores one byte indirect with or without displacement from a register to data space. For parts with SRAM, the data space consists of the Register File, I/O memory, and internal SRAM (and external SRAM if applicable). For parts without SRAM, the data space consists of the Register File only. The EEPROM has a separate address space.

The data location is pointed to by the Y (16 bits) Pointer Register in the Register File. Memory access is limited to the current data segment of 64KB. To access another data segment in devices with more than 64KB data space, the RAMPY in register in the I/O area has to be changed.

The Y-pointer Register can either be left unchanged by the operation, or it can be post-incremented or pre-decremented. These features are especially suited for accessing arrays, tables, and Stack Pointer usage of the Y-pointer Register. Note that only the low byte of the Y-pointer is updated in devices with no more than 256 bytes data space. For such devices, the high byte of the pointer is not used by this instruction and can be used for other purposes. The RAMPY Register in the I/O area is updated in parts with more than 64KB data space or more than 64KB Program memory, and the increment/ decrement/ displacement is added to the entire 24-bit address on such devices.

Not all variants of this instruction is available in all devices. Refer to the device specific instruction set summary.

The result of these combinations is undefined:

ST Y+, r28

ST Y+, r29

ST -Y, r28

ST -Y, r29

Using the Y-pointer:

Operation:		Comment:
(i) $(Y) \leftarrow Rr$		Y: Unchanged
(ii) $(Y) \leftarrow Rr, Y \leftarrow Y+1$		Y: Post incremented
(iii) $Y \leftarrow Y - 1, (Y) \leftarrow Rr$		Y: Pre decremented
(iv) $(Y+q) \leftarrow Rr$		Y: Unchanged, q: Displacement
Syntax:	Operands:	Program Counter:
(i) ST Y, Rr	$0 \leq r \leq 31$	$PC \leftarrow PC + 1$
(ii) ST Y+, Rr	$0 \leq r \leq 31$	$PC \leftarrow PC + 1$
(iii) ST -Y, Rr	$0 \leq r \leq 31$	$PC \leftarrow PC + 1$
(iv) STD Y+q, Rr	$0 \leq r \leq 31, 0 \leq q \leq 63$	$PC \leftarrow PC + 1$

16-bit Opcode:

(i)	1000	001r	rrrr	1000
(ii)	1001	001r	rrrr	1001
(iii)	1001	001r	rrrr	1010
(iv)	10q0	qq1r	rrrr	1qqq

119.2. Status Register (SREG) and Boolean Formula

I	T	H	S	V	N	Z	C
–	–	–	–	–	–	–	–

Example:

```

clr r29 ; Clear Y high byte
ldi r28,$60 ; Set Y low byte to $60
st Y+,r0 ; Store r0 in data space loc. $60(Y post inc)
st Y,r1 ; Store r1 in data space loc. $61
ldi r28,$63 ; Set Y low byte to $63
st Y,r2 ; Store r2 in data space loc. $63
st -Y,r3 ; Store r3 in data space loc. $62(Y pre dec)
std Y+2,r4 ; Store r4 in data space loc. $64

```

Words	1 (2 bytes)
Cycles	2
Cycles XMEGA	(i) 1 (ii) 1 (iii) 2 (iv) 2
Cycles Reduced Core tinyAVR	(i) 1 (ii) 1 (iii) 2

120. ST (STD) – Store Indirect From Register to Data Space using Index Z

120.1. Description

Stores one byte indirect with or without displacement from a register to data space. For parts with SRAM, the data space consists of the Register File, I/O memory, and internal SRAM (and external SRAM if applicable). For parts without SRAM, the data space consists of the Register File only. The EEPROM has a separate address space.

The data location is pointed to by the Z (16 bits) Pointer Register in the Register File. Memory access is limited to the current data segment of 64KB. To access another data segment in devices with more than 64KB data space, the RAMPZ in register in the I/O area has to be changed.

The Z-pointer Register can either be left unchanged by the operation, or it can be post-incremented or pre-decremented. These features are especially suited for Stack Pointer usage of the Z-pointer Register, however because the Z-pointer Register can be used for indirect subroutine calls, indirect jumps and table look-up, it is often more convenient to use the X- or Y-pointer as a dedicated Stack Pointer. Note that only the low byte of the Z-pointer is updated in devices with no more than 256 bytes data space. For such devices, the high byte of the pointer is not used by this instruction and can be used for other purposes. The RAMPZ Register in the I/O area is updated in parts with more than 64KB data space or more than 64KB Program memory, and the increment/decrement/displacement is added to the entire 24-bit address on such devices.

Not all variants of this instruction is available in all devices. Refer to the device specific instruction set summary.

The result of these combinations is undefined:

ST Z+, r30

ST Z+, r31

ST -Z, r30

ST -Z, r31

Using the Z-pointer:

Operation:		Comment:
(i) $(Z) \leftarrow Rr$		Z: Unchanged
(ii) $(Z) \leftarrow Rr, Z \leftarrow Z+1$		Z: Post incremented
(iii) $Z \leftarrow Z - 1, (Z) \leftarrow Rr$		Z: Pre decremented
(iv) $(Z+q) \leftarrow Rr$		Z: Unchanged, q: Displacement
Syntax:	Operands:	Program Counter:
(i) ST Z, Rr	$0 \leq r \leq 31$	$PC \leftarrow PC + 1$
(ii) ST Z+, Rr	$0 \leq r \leq 31$	$PC \leftarrow PC + 1$

- (iii) ST -Z, Rr $0 \leq r \leq 31$ $PC \leftarrow PC + 1$
- (iv) STD Z+q, Rr $0 \leq r \leq 31, 0 \leq q \leq 63$ $PC \leftarrow PC + 1$

16-bit Opcode :

(i)	1000	001r	rrrr	0000
(ii)	1001	001r	rrrr	0001
(iii)	1001	001r	rrrr	0010
(iv)	10q0	qq1r	rrrr	0qqq

120.2. Status Register (SREG) and Boolean Formula

I	T	H	S	V	N	Z	C
–	–	–	–	–	–	–	–

Example:

```
clr r31 ; Clear Z high byte
ldi r30,$60 ; Set Z low byte to $60
st Z+,r0 ; Store r0 in data space loc. $60(Z post inc)
st Z,r1 ; Store r1 in data space loc. $61
ldi r30,$63 ; Set Z low byte to $63
st Z,r2 ; Store r2 in data space loc. $63
st -Z,r3 ; Store r3 in data space loc. $62(Z pre dec)
std Z+2,r4 ; Store r4 in data space loc. $64
```

Words	1 (2 bytes)
Cycles	2
Cycles XMEGA	(i) 1 (ii) 1 (iii) 2 (iv) 2
Cycles Reduced Core tinyAVR	(i) 1 (ii) 1 (iii) 2

121. STS – Store Direct to Data Space

121.1. Description

Stores one byte from a Register to the data space. For parts with SRAM, the data space consists of the Register File, I/O memory, and internal SRAM (and external SRAM if applicable). For parts without SRAM, the data space consists of the Register File only. The EEPROM has a separate address space.

A 16-bit address must be supplied. Memory access is limited to the current data segment of 64KB. The STS instruction uses the RAMPD Register to access memory above 64KB. To access another data segment in devices with more than 64KB data space, the RAMPD in register in the I/O area has to be changed.

This instruction is not available in all devices. Refer to the device specific instruction set summary.

Operation:

- (i) (k) ← Rr

Syntax:

- (i) STS k,Rr

Operands:

$0 \leq r \leq 31, 0 \leq k \leq 65535$

Program Counter:

$PC \leftarrow PC + 2$

32-bit Opcode:

1001	001r	rrrr	0000
kkkk	kkkk	kkkk	kkkk

121.2. Status Register (SREG) and Boolean Formula

I	T	H	S	V	N	Z	C
–	–	–	–	–	–	–	–

Example:

```
lds r2,$FF00 ; Load r2 with the contents of data space location $FF00
add r2,r1 ; add r1 to r2
sts $FF00,r2 ; Write back
```

Words 2 (4 bytes)

Cycles 2

122. STS (16-bit) – Store Direct to Data Space

122.1. Description

Stores one byte from a Register to the data space. For parts with SRAM, the data space consists of the Register File, I/O memory, and internal SRAM (and external SRAM if applicable). For parts without SRAM, the data space consists of the Register File only. In some parts the Flash memory has been mapped to the data space and can be written using this command. The EEPROM has a separate address space.

A 7-bit address must be supplied. The address given in the instruction is coded to a data space address as follows:

$$\text{ADDR}[7:0] = (\overline{\text{INST}}[8], \text{INST}[8], \text{INST}[10], \text{INST}[9], \text{INST}[3], \text{INST}[2], \text{INST}[1], \text{INST}[0])$$

Memory access is limited to the address range 0x40...0xbf of the data segment.

This instruction is not available in all devices. Refer to the device specific instruction set summary.

Operation:

- (i) $(k) \leftarrow Rr$

Syntax:

- (i) STS k,Rr

Operands:

$$16 \leq r \leq 31, 0 \leq k \leq 127$$

Program Counter:

$$\text{PC} \leftarrow \text{PC} + 1$$

16-bit Opcode:

1010	1kkk	rrrr	kkkk
------	------	------	------

122.2. Status Register (SREG) and Boolean Formula

I	T	H	S	V	N	Z	C
–	–	–	–	–	–	–	–

Example:

```
lds r16,$00 ; Load r16 with the contents of data space location $00
add r16,r17 ; add r17 to r16
sts $00,r16 ; Write result to the same address it was fetched from
```

Words 1 (2 bytes)

Cycles 1

Note: Registers r0...r15 are remapped to r16. r31

123. SUB – Subtract Without Carry

123.1. Description

Subtracts two registers and places the result in the destination register Rd.

Operation:

$$(i) \quad R_d \leftarrow R_d - R_r$$

Syntax:

$$(i) \quad \text{SUB } R_d, R_r$$

Operands:

$$0 \leq d \leq 31, 0 \leq r \leq 31$$

Program Counter:

$$PC \leftarrow PC + 1$$

16-bit Opcode:

0001	10rd	dddd	rrrr
------	------	------	------

123.2. Status Register and Boolean Formula

I	T	H	S	V	N	Z	C
–	–	↔	↔	↔	↔	↔	↔

$$\mathbf{H} \quad \overline{R_d3} \cdot R_r3 + R_r3 \cdot R3 + R3 \cdot \overline{R_d3}$$

Set if there was a borrow from bit 3; cleared otherwise.

$$\mathbf{S} \quad N \oplus V, \text{ for signed tests.}$$

$$\mathbf{V} \quad R_d7 \cdot \overline{R_r7} \cdot \overline{R7} + R_d7 \cdot R_r7 \cdot R7$$

Set if two's complement overflow resulted from the operation; cleared otherwise.

$$\mathbf{N} \quad R7$$

Set if MSB of the result is set; cleared otherwise.

$$\mathbf{Z} \quad \overline{R7} \cdot \overline{R6} \cdot \overline{R5} \cdot \overline{R4} \cdot \overline{R3} \cdot \overline{R2} \cdot \overline{R1} \cdot \overline{R0}$$

Set if the result is \$00; cleared otherwise.

$$\mathbf{C} \quad \overline{R_d7} \cdot R_r7 + R_r7 \cdot R7 + R7 \cdot \overline{R_d7}$$

Set if the absolute value of the contents of Rr is larger than the absolute value of Rd; cleared otherwise.

R (Result) equals Rd after the operation.

Example:

```
sub r13,r12 ; Subtract r12 from r13
brne noteq ; Branch if r12<>r13
...
noteq: nop ; Branch destination (do nothing)
```

Words

1 (2 bytes)

Cycles

1

124. SUBI – Subtract Immediate

124.1. Description

Subtracts a register and a constant, and places the result in the destination register Rd. This instruction is working on Register R16 to R31 and is very well suited for operations on the X, Y, and Z-pointers.

Operation:

$$(i) \quad R_d \leftarrow R_d - K$$

Syntax:

$$(i) \quad \text{SUBI } R_d, K$$

Operands:

$$16 \leq d \leq 31, 0 \leq K \leq 255$$

Program Counter:

$$PC \leftarrow PC + 1$$

16-bit Opcode:

0101	KKKK	dddd	KKKK
------	------	------	------

124.2. Status Register and Boolean Formula

I	T	H	S	V	N	Z	C
–	–	↔	↔	↔	↔	↔	↔

$$\mathbf{H} \quad \overline{Rd3} \cdot K3 + K3 \cdot R3 + R3 \cdot \overline{Rd3}$$

Set if there was a borrow from bit 3; cleared otherwise.

$$\mathbf{S} \quad N \oplus V, \text{ for signed tests.}$$

$$\mathbf{V} \quad Rd7 \cdot \overline{K7} \cdot \overline{R7} + \overline{Rd7} \cdot K7 \cdot R7$$

Set if two's complement overflow resulted from the operation; cleared otherwise.

$$\mathbf{N} \quad R7$$

Set if MSB of the result is set; cleared otherwise.

$$\mathbf{Z} \quad \overline{R7} \cdot \overline{R6} \cdot \overline{R5} \cdot \overline{R4} \cdot \overline{R3} \cdot \overline{R2} \cdot \overline{R1} \cdot \overline{R0}$$

Set if the result is \$00; cleared otherwise.

$$\mathbf{C} \quad \overline{Rd7} \cdot K7 + K7 \cdot R7 + R7 \cdot \overline{Rd7}$$

Set if the absolute value of K is larger than the absolute value of Rd; cleared otherwise.

R (Result) equals Rd after the operation.

Example:

```
subi r22,$11 ; Subtract $11 from r22
brne noteq ; Branch if r22<>$11
...
noteq: nop ; Branch destination (do nothing)
```

Words

1 (2 bytes)

Cycles

1

125. SWAP – Swap Nibbles

125.1. Description

Swaps high and low nibbles in a register.

Operation:

- (i) $R(7:4) \leftarrow R(3:0)$, $R(3:0) \leftarrow R(7:4)$

Syntax:

Operands:

Program Counter:

- (i) SWAP Rd

$0 \leq d \leq 31$

$PC \leftarrow PC + 1$

16-bit Opcode:

1001	010d	dddd	0010
------	------	------	------

125.2. Status Register (SREG) and Boolean Formula

I	T	H	S	V	N	Z	C
–	–	–	–	–	–	–	–

R (Result) equals Rd after the operation.

Example:

```
inc r1 ; Increment r1
swap r1 ; Swap high and low nibble of r1
inc r1 ; Increment high nibble of r1
swap r1 ; Swap back
```

Words 1 (2 bytes)

Cycles 1

126. TST – Test for Zero or Minus

126.1. Description

Tests if a register is zero or negative. Performs a logical AND between a register and itself. The register will remain unchanged.

Operation:

(i) $Rd \leftarrow Rd \cdot Rd$

Syntax:

Operands:

Program Counter:

(i) TST Rd

$0 \leq d \leq 31$

$PC \leftarrow PC + 1$

16-bit Opcode: (see AND Rd, Rd)

0010	00dd	dddd	dddd
------	------	------	------

126.2. Status Register (SREG) and Boolean Formula

I	T	H	S	V	N	Z	C
–	–	–	↔	0	↔	↔	–

S $N \oplus V$, for signed tests.

V 0

Cleared.

N R7

Set if MSB of the result is set; cleared otherwise.

Z $\overline{R7} \cdot \overline{R6} \cdot \overline{R5} \cdot \overline{R4} \cdot \overline{R3} \cdot \overline{R2} \cdot \overline{R1} \cdot \overline{R0}$

Set if the result is \$00; cleared otherwise.

R (Result) equals Rd.

Example:

```
tst r0 ; Test r0
breq zero ; Branch if r0=0
...
zero: nop ; Branch destination (do nothing)
```

Words 1 (2 bytes)

Cycles 1

127. WDR – Watchdog Reset

127.1. Description

This instruction resets the Watchdog Timer. This instruction must be executed within a limited time given by the WD prescaler. See the Watchdog Timer hardware specification.

Operation:

- (i) WD timer restart.

Syntax:

Operands:

Program Counter:

- (i) WDR

None

$PC \leftarrow PC + 1$

16-bit Opcode:

1001	0101	1010	1000
------	------	------	------

127.2. Status Register (SREG) and Boolean Formula

I	T	H	S	V	N	Z	C
–	–	–	–	–	–	–	–

Example:

```
wdr ; Reset watchdog timer
```

Words 1 (2 bytes)

Cycles 1

128. XCH – Exchange

128.1. Description

Exchanges one byte indirect between register and data space.

The data location is pointed to by the Z (16 bits) Pointer Register in the Register File. Memory access is limited to the current data segment of 64KB. To access another data segment in devices with more than 64KB data space, the RAMPZ in register in the I/O area has to be changed.

The Z-pointer Register is left unchanged by the operation. This instruction is especially suited for writing/reading status bits stored in SRAM.

Operation:

- (i) $(Z) \leftarrow Rd, Rd \leftarrow (Z)$

Syntax:

Operands:

Program Counter:

- (i) XCH Z,Rd

$0 \leq d \leq 31$

$PC \leftarrow PC + 1$

16-bit Opcode:

1001	001r	rrrr	0100
------	------	------	------

128.2. Status Register (SREG) and Boolean Formula

I	T	H	S	V	N	Z	C
–	–	–	–	–	–	–	–

Words 1 (2 bytes)

Cycles 2

129. Datasheet Revision History

Note that the referring page numbers in this section are referred to this document. The referring revision in this section is referred to the document revision.

129.1. Rev.0856L - 11/2016

A complete review of the document.

New document template.

129.2. Rev.0856K - 04/2016

A note has been added to section "[RETI – Return from Interrupt](#)".

129.3. Rev.0856J - 07/2014

Section "[Conditional Branch Summary](#)" has been corrected.

2. The first table in section "[Description](#)" has been corrected.

3. "TBD" in "Example" in section "[Description](#)" has been removed.

4. The LAC operation in section "[LAC – Load and Clear](#)" has been corrected.

5. New template has been added.

129.4. Rev.0856I – 07/2010

1. Updated section "[Instruction Set Summary](#)" with new instructions: LAC, LAS, LAT, and XCH.

Section "[LAC - Load and Clear](#)"

Section "[LAS – Load and Set](#)"

Section "[LAT – Load and Toggle](#)"

Section "[XCH – Exchange](#)"

2. Updated number of clock cycles column to include Reduced Core tinyAVR.

(ATtiny replaced by Reduced Core tinyAVR).

129.5. Rev.0856H – 04/2009

1. Updated section "[Instruction Set Summary](#)":

Updated number of clock cycles column to include Reduced Core tinyAVR.

2. Updated sections for Reduced Core tinyAVR compatibility:

Section "[CBI – Clear Bit in I/O Register](#)"

Section "[LD – Load Indirect from Data Space to Register using Index X](#)"

Section "[LD \(LDD\) – Load Indirect from Data Space to Register using Index Y](#)"

Section "[LD \(LDD\) – Load Indirect From Data Space to Register using Index Z](#)"

Section "RCALL – Relative Call to Subroutine"

Section "SBI – Set Bit in I/O Register"

Section "ST – Store Indirect From Register to Data Space using Index X"

Section "ST (STD) – Store Indirect From Register to Data Space using Index Y"

Section "ST (STD) – Store Indirect From Register to Data Space using Index Z"

3. Added sections for Reduced Core tinyAVR compatibility:

Section "LDS (16-bit) – Load Direct from Data Space"

Section "STS (16-bit) – Store Direct to Data Space"

129.6. Rev.0856G – 07/2008

1. Inserted "Datasheet Revision History".
2. Updated "Cycles XMEGA" for ST, by removing (iv).
3. Updated "SPM #2" opcodes.

129.7. Rev.0856F – 05/2008

1. This revision is based on the AVR Instruction Set 0856E-AVR-11/05.

Changes done compared to AVR Instruction Set 0856E-AVR-11/05:

- Updated "Complete Instruction Set Summary" with DES and SPM #2.
- Updated AVR Instruction Set with XMEGA Clock cycles and Instruction Description.

Atmel®, Atmel logo and combinations thereof, Enabling Unlimited Possibilities®, AVR®, megaAVR®, tinyAVR®, XMEGA®, and others are registered trademarks or trademarks of Atmel Corporation in U.S. and other countries. Other terms and product names may be trademarks of others.

DISCLAIMER: The information in this document is provided in connection with Atmel products. No license, express or implied, by estoppel or otherwise, to any intellectual property right is granted by this document or in connection with the sale of Atmel products. EXCEPT AS SET FORTH IN THE ATMEL TERMS AND CONDITIONS OF SALES LOCATED ON THE ATMEL WEBSITE, ATMEL ASSUMES NO LIABILITY WHATSOEVER AND DISCLAIMS ANY EXPRESS, IMPLIED OR STATUTORY WARRANTY RELATING TO ITS PRODUCTS INCLUDING, BUT NOT LIMITED TO, THE IMPLIED WARRANTY OF MERCHANTABILITY, FITNESS FOR A PARTICULAR PURPOSE, OR NON-INFRINGEMENT. IN NO EVENT SHALL ATMEL BE LIABLE FOR ANY DIRECT, INDIRECT, CONSEQUENTIAL, PUNITIVE, SPECIAL OR INCIDENTAL DAMAGES (INCLUDING, WITHOUT LIMITATION, DAMAGES FOR LOSS AND PROFITS, BUSINESS INTERRUPTION, OR LOSS OF INFORMATION) ARISING OUT OF THE USE OR INABILITY TO USE THIS DOCUMENT, EVEN IF ATMEL HAS BEEN ADVISED OF THE POSSIBILITY OF SUCH DAMAGES. Atmel makes no representations or warranties with respect to the accuracy or completeness of the contents of this document and reserves the right to make changes to specifications and products descriptions at any time without notice. Atmel does not make any commitment to update the information contained herein. Unless specifically provided otherwise, Atmel products are not suitable for, and shall not be used in, automotive applications. Atmel products are not intended, authorized, or warranted for use as components in applications intended to support or sustain life.

SAFETY-CRITICAL, MILITARY, AND AUTOMOTIVE APPLICATIONS DISCLAIMER: Atmel products are not designed for and will not be used in connection with any applications where the failure of such products would reasonably be expected to result in significant personal injury or death ("Safety-Critical Applications") without an Atmel officer's specific written consent. Safety-Critical Applications include, without limitation, life support devices and systems, equipment or systems for the operation of nuclear facilities and weapons systems. Atmel products are not designed nor intended for use in military or aerospace applications or environments unless specifically designated by Atmel as military-grade. Atmel products are not designed nor intended for use in automotive applications unless specifically designated by Atmel as automotive-grade.